

Equipment
for engineering
education

Engineering mechanics
and engineering design



Table of contents

Welcome to GUNT

In this catalogue, we present a comprehensive overview of our innovative demonstration and experimental units.

GUNT units are used for:

- education in technical professions
- training and education of technical personnel in trade and industry
- studies in engineering disciplines

Engineering mechanics and engineering design

	Introduction	004
1	Engineering mechanics – statics	008
2	Engineering mechanics – strength of materials	076
3	Engineering mechanics – dynamics	142
4	Machine dynamics	182
5	Engineering design	252
6	Materials testing	314
	Index	380
	Product overview	386

Imprint

© 2018 G.U.N.T. Gerätebau GmbH. Any reuse, storage, duplication and reproduction of content – even in extracts – is prohibited without the written approval of G.U.N.T. Gerätebau GmbH. GUNT is a registered trademark. This means GUNT products are protected, and subject to copyright.

No liability can be accepted for any misprints. Subject to change without notice.

Image credits: G.U.N.T. Gerätebau GmbH, manufacturers' photos, Shutterstock, 123RF. Design & typesetting: Profisatz.Graphics, Bianca Buhmann, Hamburg. Printed on non-chlorinated, environmentally friendly paper.

Teaching and learning systems for the fields of engineering mechanics, engineering design, and materials testing

Besides mathematical theory and scientific fundamentals, technological principles and engineering design form the foundation of fundamental engineering education.

Studies in the field of engineering are always focused on fundamentals and methodologies from the outset. As studies progress, the sound fundamental knowledge that has been acquired

serves as the basis for more in-depth investigations and as such is a pre-requisite for the development of any engineering programme.

Fundamentals and disciplines of engineering skills

The development of engineering skills requires fundamental knowledge relating to mathematical and scientific foundations, technological principles and engineering design, originating from

discrete disciplines such as mechanics, physics, thermodynamics and technical design. The figure below illustrates the relation between the fundamental knowledge and the related disciplines.

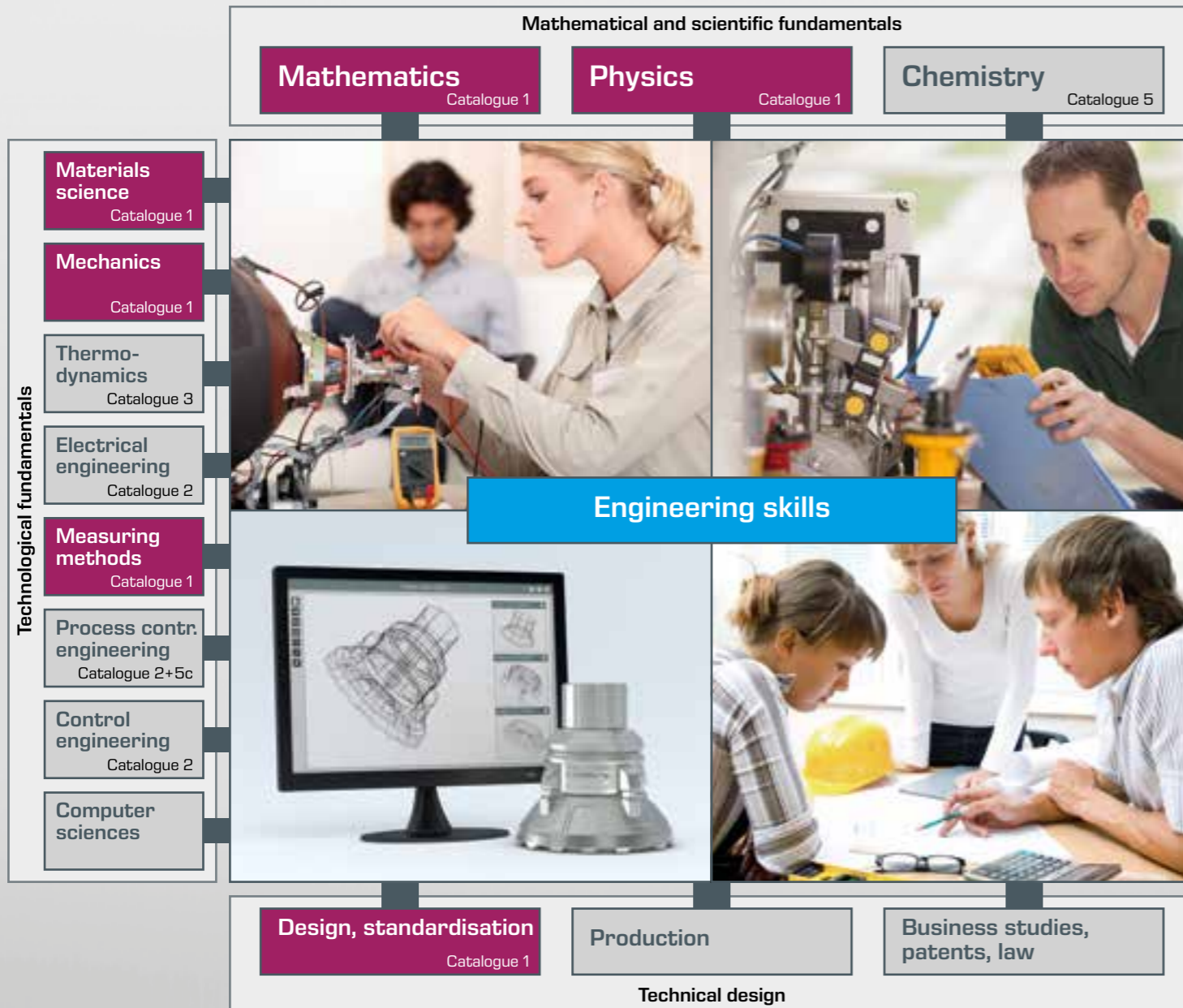

What can GUNT do for you?

Well-founded knowledge of the fundamentals is essential in technical development to design complex systems.

GUNT units help you to obtain this basic knowledge through hands-on experience. Practical experience in using the various components of the system and its machine elements and materials in a correct and appropriate manner is important. Thus, knowledge derives from **practice**.

Your success is our goal!

Catalogue 1 includes units for demonstrations and experiments, which are helpful for developing the disciplines of engineering mechanics, engineering design, and materials testing.

In addition to single units, GUNT has developed series of units that cover a topic entirely. The different units in a series are all built upon each other. Although each unit focuses on a different issue or question, the topics are interrelated and constitute a complete subject area.



Improving the people's quality of life through the development and application of technology.

Teaching and learning systems for the fields of engineering mechanics, engineering design, and materials testing

Structure of the catalogue

Students are prepared for a career in engineering by educating them on the basic disciplines of engineering mechanics, machine elements, engineering design, and materials testing. The following table is an excerpt from a typical curriculum of a technical

university, which is based on the tables of contents of reference books on engineering mechanics. GUNT units cover most of these topics.

Engineering mechanics			
Statics Chapter 1	Strength of materials Chapter 2	Dynamics (kinematics and kinetics) Chapter 3	Machine dynamics Chapter 4
<ul style="list-style-type: none"> forces and moments, axioms of statics planar force systems, equilibrium conditions method of sections and internal forces: normal force, shear force, and bending moment beams, trusses, bridges, members static and kinetic friction 	<ul style="list-style-type: none"> stresses in: tension, pressure, thrust, and torsion buckling problems deformations, stresses law of elasticity energy methods principle of virtual work experimental stress and strain analysis 	<ul style="list-style-type: none"> kinematics of a point, kinematics of a rigid body kinetics of the mass point systems of mass points body dynamics vibrations 	<ul style="list-style-type: none"> vibrations in machines torsional vibrations of drive systems, bending vibrations
Engineering design		Machine elements & assembly exercises	
Engineering drawings & cutaway models Chapter 5	Machine elements & assembly exercises Chapter 5		
<ul style="list-style-type: none"> development of spatial perception three-dimensional display sectional view design guidelines cutaway models 	<ul style="list-style-type: none"> elements of connecting technology bearings transmission / conversion elements assembly exercises 		
Materials testing			
Materials testing Chapter 6			
<ul style="list-style-type: none"> mechanical testing of materials tensile, pressure, bending, hardness, torsion tests impact test 		<ul style="list-style-type: none"> material fatigue, fatigue limit tribology corrosion 	



1 Engineering mechanics – statics



Introduction	
Overview Engineering mechanics	010
Basic knowledge Statics	012
Overview Experimental units for the field of statics	014

Forces and moments	
TM 110 Fundamentals of statics	016
TM 110.01 Supplementary set – inclined plane and friction	018
TM 110.02 Supplementary set – pulley blocks	019
TM 110.03 Supplementary set – gear wheels	020
TM 115 Forces in a crane jib	021
FL 111 Forces in a simple bar structure	022
EM 049 Equilibrium of moments on a two-arm lever	023
SE 110.53 Equilibrium in a single plane, statically determinate system	024
TM 121 Equilibrium of moments on pulleys	026
TM 122 Equilibrium of moments on a differential pulley block	027

Internal reactions and methods of section	
Basic knowledge Internal reactions and methods of sections for bars, beams and cables	028
WP 960 Beam on two supports: shear force & bending moment diagrams	030
WP 961 Beam on two supports: shear force diagram	032
WP 962 Beam on two supports: bending moment diagram	033
SE 110.50 Cable under dead-weight	034

Forces in a truss	
Basic knowledge Method of sections for plane trusses	036
SE 110.21 Forces in various single plane trusses	038
SE 110.22 Forces in an overdeterminate truss	040
SE 130 Forces in a Howe truss	042
SE 130.01 Truss beam: Warren girder	044

Bridges, beams, arches, cables	
SE 110.18 Forces on a suspension bridge	046
SE 110.12 Lines of influence on the Gerber beam	048
SE 110.17 Three-hinged arch	050
SE 110.16 Parabolic arch	052

Accessories	
Overview FL 152 PC-based recording and analysis of strain gauge signals	054
FL 152 Multi-channel measuring amplifier	056
SE 112 Mounting frame	058
Flyer Course engineering mechanics	060

Static and kinetic friction	
Basic knowledge Static and kinetic friction	068
TM 210 Dry friction	070
TM 200 Fundamentals of mechanical friction	072
TM 225 Friction on the inclined plane	073
TM 220 Belt drive and belt friction	074

Engineering mechanics

The basic engineering discipline is engineering mechanics, which describes the motions of bodies and the forces associated with these motions.

Engineering mechanics investigates the equilibrium of forces as well as the resulting components' stresses and deformations. Based on characteristics such as strength, permissible stresses, or deformations, a component is designed by comparing the applied stress with the capacity to withstand stress. This requires that the stress on a component is less than its capacity to withstand stresses.

In conjunction with the basic fields of materials science and machine elements, engineering mechanics provides fundamental calculation methods for creating engineering designs. Consequently, engineering mechanics should be understood as a bridge between theoretical knowledge and practical implementation, without which an understanding and comprehensive analysis of complex technical systems would not be possible.

In universities, the discipline of engineering mechanics is usually divided into the following subdisciplines:

- **engineering mechanics I**, focusing on statics
- **engineering mechanics II**, focusing on strength of materials (elastostatics)
- **engineering mechanics III**, focusing on kinematics and kinetics (dynamics)

General classification of the discipline of engineering mechanics and placement in this catalogue

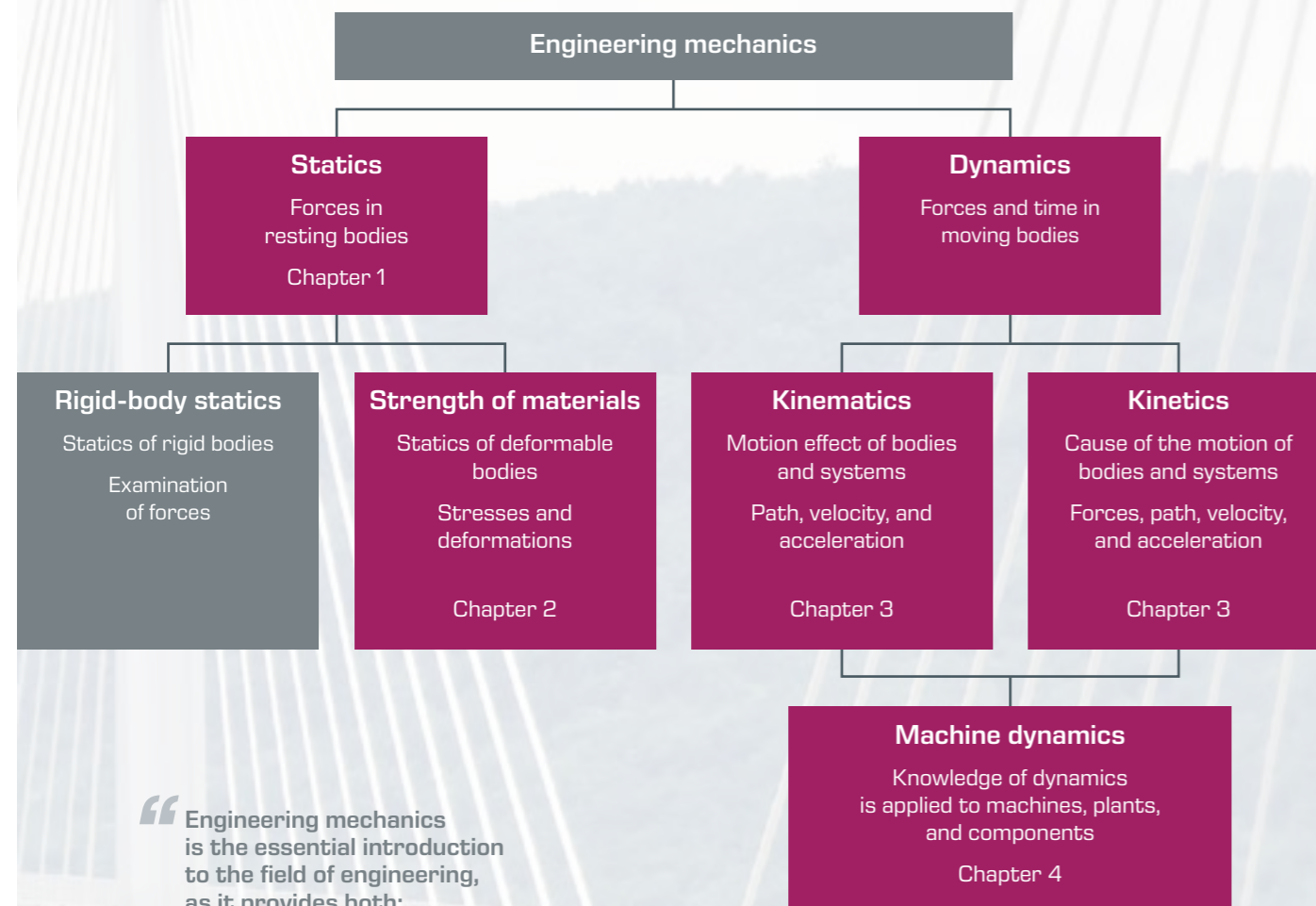

“Engineering mechanics is the essential introduction to the field of engineering, as it provides both: learning content and methodological training.”

Prof. Dr.-Ing. Frank Mestemacher,
Department of Mechanical Engineering, Fachhochschule Stralsund.

Topics in engineering mechanics

Statics

Statics courses include elementary knowledge for analysing loads on mechanical systems. This knowledge forms the basis for sizing and designing components and machine elements.

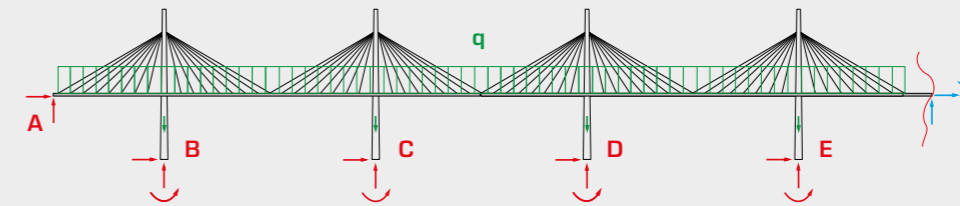

Distribution of forces using the example of Millau Viaduct



Strength of materials

Strength of materials deals with the deformation of elastic systems under loads such as pressure, tension, bending, torsion, and shearing as well as calculating the resulting stress states.

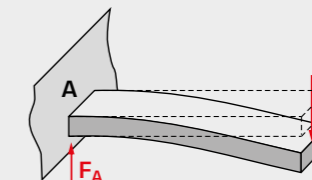

Bending stress of a cantilever beam using the example of a diving board



Dynamics (kinematics and kinetics)

Dynamics investigates moving systems. Kinematics deals with motion sequences without enquiring into the cause of motion. Kinetics looks at the motion of rigid bodies under the action of forces.

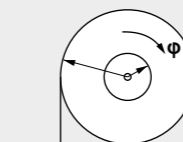

Motion of rigid bodies using the example of a hoist crane

Machine dynamics

Building on the fundamentals of engineering mechanics, machine dynamics deals with the interaction between dynamic forces and motion quantities in machines.



Oscillating and rotating inertia forces using the example of a reciprocating piston pump

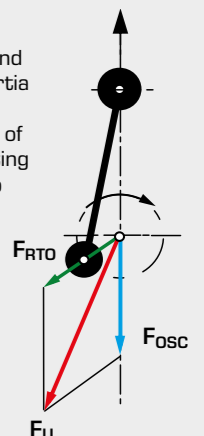

Basic knowledge

Statics

Statics is the study of the effect of forces on rigid bodies, which are in equilibrium. Two forces are in equilibrium when they are equal, in opposing directions, and have the same line of action. In statics, a body is considered rigid when deformations, caused by acting forces, are negligibly small compared to the dimensions of the body.

The main task of static analysis is to determine the equilibrium of the forces applied on a body or a mechanical system. Building on the axioms of mechanics, rigid-body mechanics deals with the equivalence and equilibrium of force systems, centre-of-gravity calculations, internal forces, and moments in beams and trusses along with problems on friction. Generally, the field looks at supporting structures that are at rest and that must remain at rest owing to their function. Material properties are not considered in statics; these are covered by strength of materials.

Basic terms of statics

Force, as the cause of motion changes and/or deformations, is described by its magnitude, the position of the line of action, and direction along the line of action. Forces are divided according to different criteria:

Division by dimension

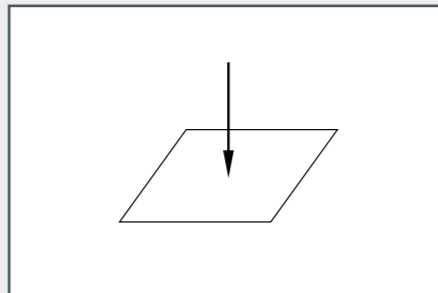

Point force:
only acts on a point
(idealisation in mechanics)

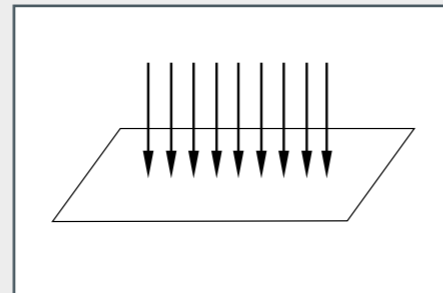

Linear force / line load:
continuously distributed force along a line
(idealisation in mechanics)

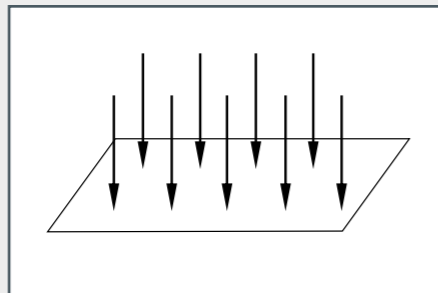

Area force:
affects only a specific area or is applied as a compressive load (water pressure on a dam, load of snow on a roof)

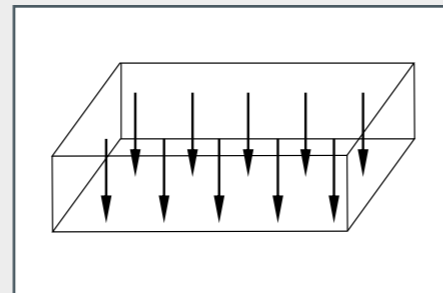

Volume force:
acts spatially distributed over the volume of a body (weight, magnetic and electrical forces)

Division by origin

Physical force or active force (F , q): acts in the normal direction on a body (e.g. weight, wind pressure and snow).

Reaction force or constraining force (A_V , A_H , B_V): acts in the opposite direction to the physical force and causes the body to remain in equilibrium (e.g. normal force F_N , support force and adhesive force).

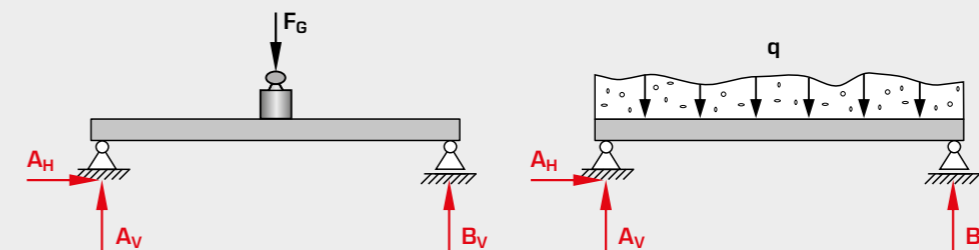

Division in the system

Internal force: obtained by notionally cutting the body. This force acts between the parts of a body or system (normal force N , shear force Q and bending moment M).

External force: acts on a body from the outside (e.g. weight, wind pressure, snow load, adhesive force and support force)

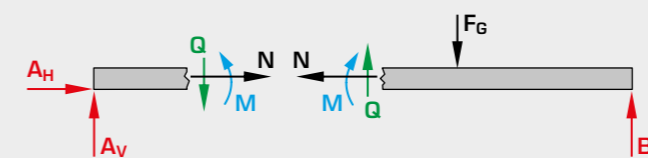

F_G weight, q snow load, A and B support forces, **index V** vertical forces, **index H** horizontal forces, N normal force, Q shear force, M bending moment

Axioms of statics

Axiom of inertia:

Every body remains in a state of rest or uniform rectilinear motion unless it is compelled to change this state by the forces acting on it.

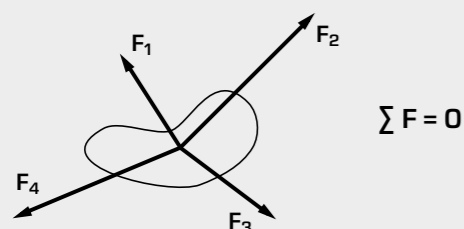

Axiom of displacement:

Two forces that are equal, have the same line of action and are in the same direction but different points of action, exert the same action on a rigid body, i.e. they are equivalent. In other words, the force vector can be displaced along the line of action.

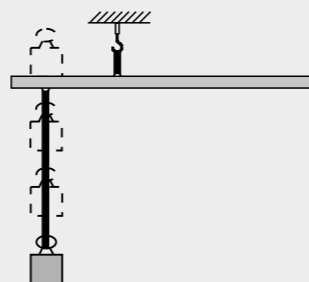

Axiom of the parallelogram:

The action of two forces with a common point of action is equivalent to the action of a single force, whose vector is given as a diagonal in a parallelogram and which has the same point of action as the forces.

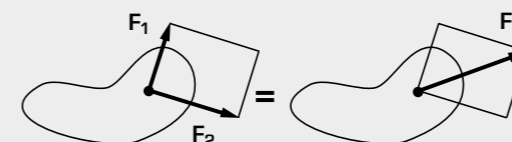

Axiom of reaction:

If a body exerts a force on a second body (action), this causes the second body to also exert a force on the first body (reaction), which is equal to the first force in magnitude and line of action, but which is in the opposite direction.

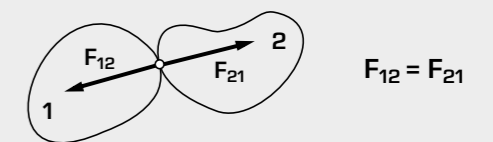

Experimental units for the field of statics

The engineering mechanics – statics chapter offers examples on the following subject areas:

Forces and moments

- demonstration of forces and graphical resolution of forces
- investigation of lever systems
- planar central force systems and statically defined systems
- bar forces, support forces, equilibrium of forces, equilibrium of moments and equilibrium conditions



TM 115 Forces in a crane jib

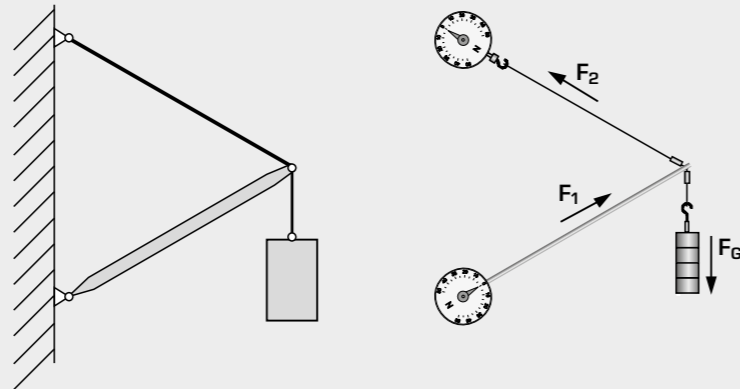

Resolution of forces on the planar central force system
External forces: F_1 and F_2 bar forces and F_G weight

Internal reactions and methods of section

- demonstration of internal reactions
- application of the method of sections
- investigation of normal force, shear force and bending moment diagrams

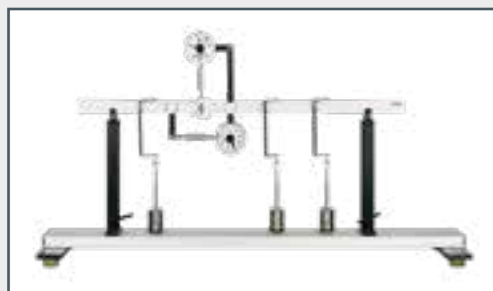

WP 960 Beam on two supports:
shear force & bending moment diagrams

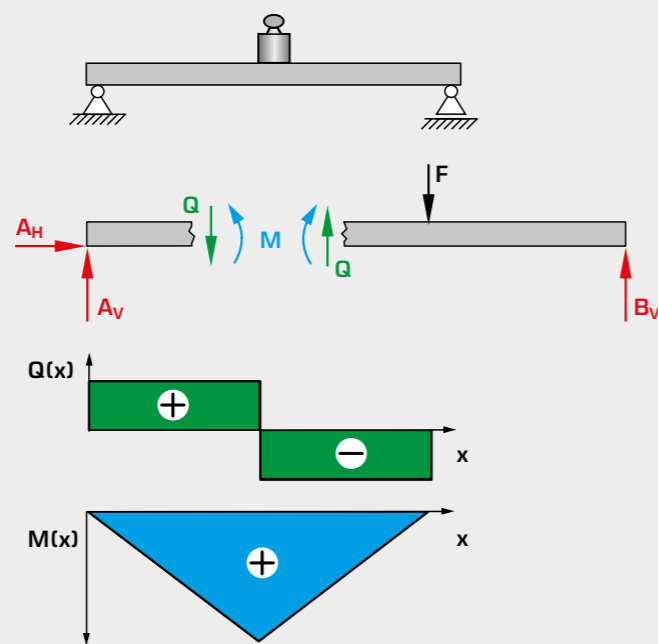

Internal reactions in a beam
 F external force, A_V , A_H , B_V support forces, Q shear force, M bending moment

Forces in a truss

- bar forces in statically determinate and indeterminate trusses
- dependence of bar forces on external forces
- method of sections: method of joints and Ritter's method
- graphical method: Cremona diagram

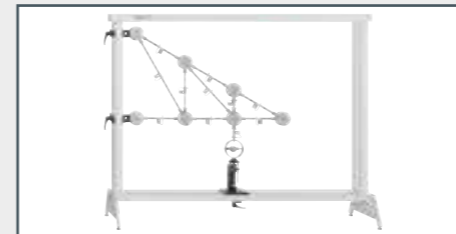

SE 110.21 Forces in various single plane trusses

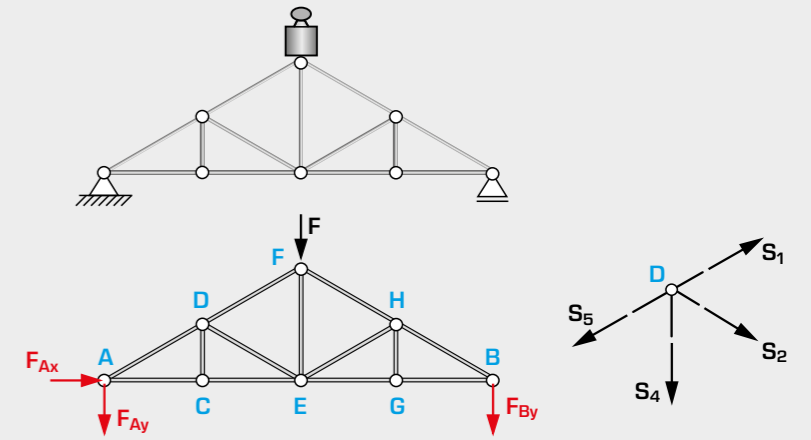

Method of joints to determining the forces on a truss
 F force, F_{Ax} , F_{Ay} , F_{Bx} , F_{By} support forces, S bar forces, $A-H$ joints

Bridges, beams, arches and cables

- calculation of support forces
- determining internal reactions
- different load cases: point load, line load and moving load

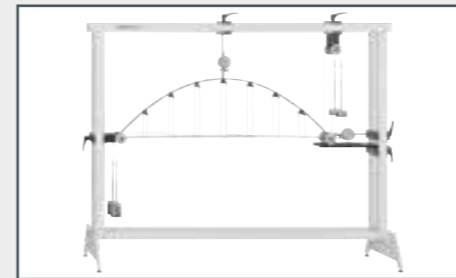

SE 110.16 Parabolic arch

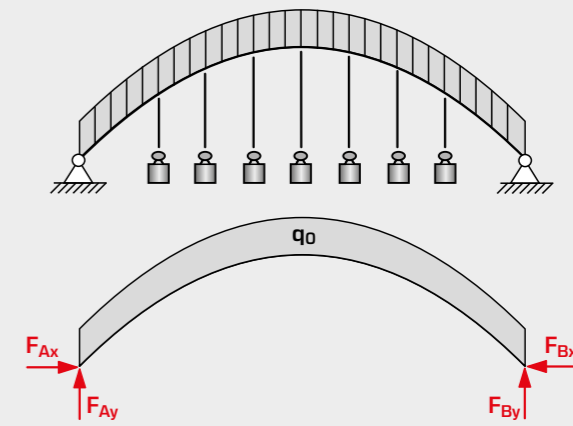

Line load and support reactions on an arch
 F_{Ax} , F_{Ay} , F_{Bx} , F_{By} support forces, q_0 line load

Static and kinetic friction

- static and dynamic friction
- demonstration of frictional forces
- determining the coefficients of friction



TM 225 Friction on the inclined plane

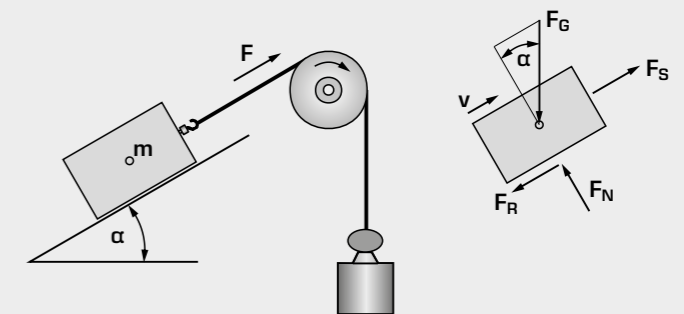

Friction on the inclined plane
 F_G weight, F_S external force, F_N normal force, F_R dynamic friction force, v velocity, α angle of inclination, m mass

TM 110

Fundamentals of statics



Description

- versatile experimental unit demonstrating planar mechanical force systems
- scope of experimentation can be extended by supplementary sets

The experimental unit demonstrates fundamental principles of statics such as the equilibrium of forces and moments, resolution of forces, the law of levers, and more.

The base element is an upright panel. Feet enable the panel to stand on a laboratory bench. All parts required for the experiment can be quickly attached to the rails around the edges. The imprinted line grid and grid-marked lever rods permit precise assembly. The lengths marked on the grid make it easy to define angles. A wide range of mountings, such as cables, rods, pulleys, torque disks, pivot bearings and the like, can be easily fixed in place and combined. Ball bearings integrated into the panel permit low-friction torque experiments. The versatility of the experimental unit helps students to explore their creativity in developing their own experiments.

Large-format force gauges are particularly well suited to demonstration purposes. The adjustable transparent dial enables input loads, such as dead-weights, to be taken into account.

As a special teaching aid, it is possible to write directly on the panel with erasable markers. Markings, sketches and comments can be added to supplement the experiments. All parts are clearly laid out and well protected on a storage system. The storage systems are stackable, providing for space-saving storage.

Three supplementary sets are available to extend the scope of experimentation, providing additional experiments relating to the inclined plane, friction, pulley blocks and gear wheels.

Learning objectives/experiments

- accumulation and resolution of forces with force parallelogram
- equilibrium of forces
- law of levers, determination of moments and equilibrium of moments
- combined lever systems
- forces in bearings
- deflection and resolution of force by fixed and free pulleys
- together with supplementary sets
 - ▶ inclined plane; friction (TM 110.01)
 - ▶ pulley blocks (TM 110.02)
 - ▶ gear wheels (TM 110.03)

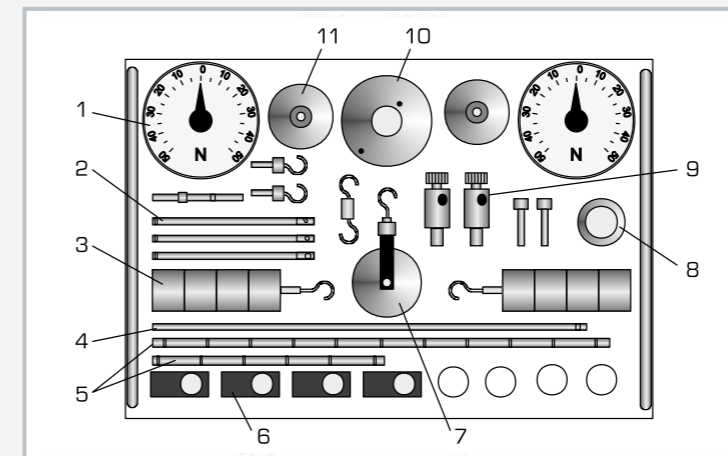

1 force gauge, 2 pull rod, 3 weight with hanger, 4 pull-and-push rod, 5 lever rod, 6 slide fixings, 7 free pulley, 8 torque disk, 9 pivot bearing, 10 torque disk with bearing, 11 pulley

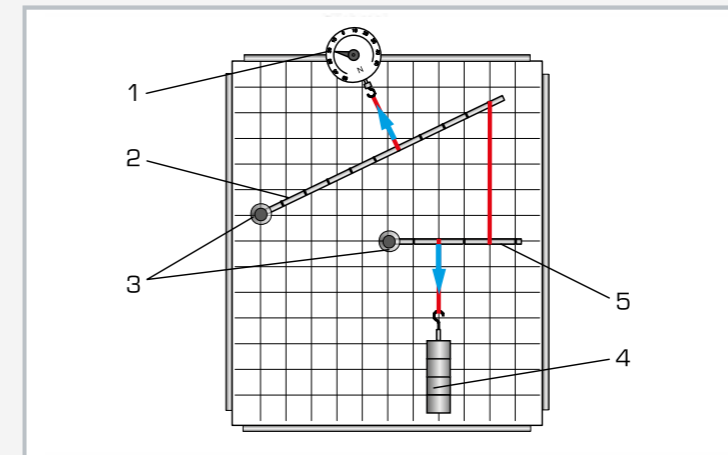

Experimental setup combined lever system:
1 force gauge, 2 long lever rod, 3 pivot bearing, 4 weight, 5 short lever rod; red: cables, blue: forces

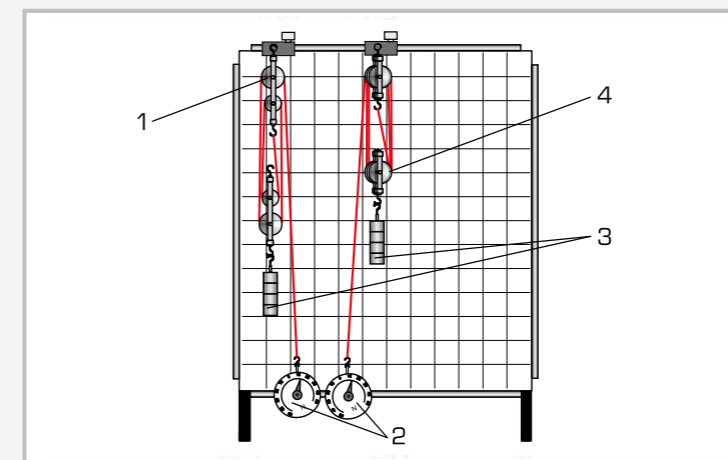

Experimental setup with the pulley blocks supplementary set (TM 110.02):
1 four-cable pulley block, 2 force gauge, 3 weight, 4 six-cable pulley block

Specification

- [1] experimental setup to demonstrate simple, planar force systems
- [2] panel with rails around the edges for easy mounting of various experimental components
- [3] panel with imprinted 50mm line grid and facility to write on using erasable marker
- [4] lever rods with 50mm grid
- [5] wide range of mountings: cables, rods, pulleys, torque disks, pivot bearings and the like
- [6] force gauges for tensile and compressive forces, with large-format display
- [7] transparent dial on force gauge rotatable
- [8] storage system to house all parts

Technical data

Panel
 ■ WxH: 600x700mm, 13kg
 ■ line grid: 50mm

Force gauges for tensile and compressive force
 ■ measuring range: $\pm 50\text{N}$
 ■ display diameter: $\varnothing = 110\text{mm}$
 ■ protected against overloading

Weights
 ■ 2x 5N (hanger)
 ■ 6x 5N

WxH: 600x700mm (panel)
 LxWxH: 604x404x132mm (storage system)
 Weight: approx. 30kg

Scope of delivery

- 1 panel
- 1 set of mountings
- 1 set of weights
- 1 storage system with foam inlay
- 1 set of instructional material

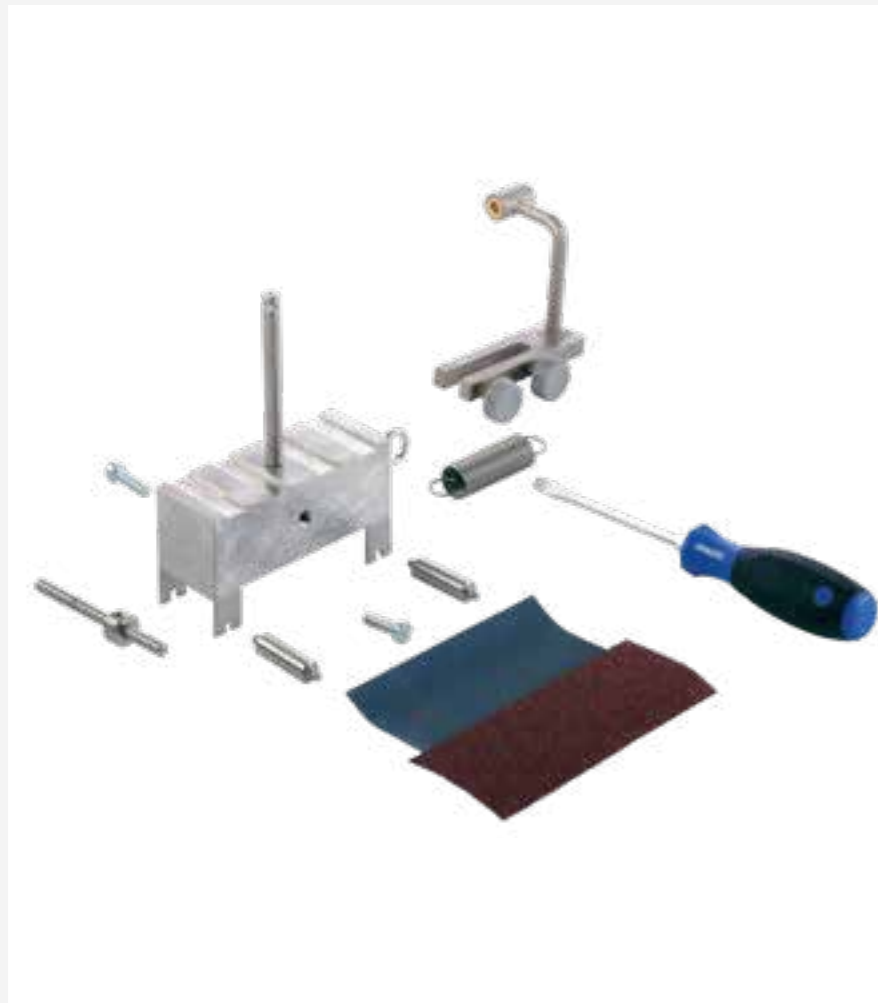
TM 110.01**Supplementary set - inclined plane and friction**

The illustration shows the parts of TM 110.01 without rail.

Description

■ **measurement and demonstration of spring deflection, inclined plane and mechanical friction**

Supplementary set TM 110.01 extends the scope of experiments which can be performed with TM 110 with the issues: elastic deflection of a helical spring, forces on the inclined plane and friction.

The inclined plane is provided by an aluminium rail. For friction experiments, a friction body is used which has side faces prepared for different friction conditions.

All parts are clearly laid out and well protected on a storage system. The storage systems are stackable, providing for space-saving storage.

Learning objectives/experiments

- elastic deflection of a helical spring (Hooke's law)
- dynamic friction as a function of the normal force, contact area and surface properties of the friction body
- determination of the friction coefficient
- rolling friction
- forces on the inclined plane

Specification

- [1] supplementary set for experimental unit TM 110
- [2] experiments relating to Hooke's law: friction and inclined plane
- [3] friction body which can be set up to give 3 different surface options
- [4] rail forming the inclined plane
- [5] steel helical spring
- [6] storage system to house all parts

Technical data**Helical spring**

- spring constant: approx. 0,95N/cm
- max. load: 25N

Aluminium friction body

- LxWxH: 110x40x40mm
- dead-load: 5N
- 2 sides with different sized areas
- 2 sides with different surface roughnesses

Aluminium rail, anodised

- LxWxH: 800x50x10mm

LxWxH: 160x103x75mm (storage system)

Weight: approx. 5kg

Scope of delivery

- 1 supplementary set
- 1 storage system
- 1 set of instructional material

TM 110.02**Supplementary set - pulley blocks****Description**

■ **setup and principle of three different pulley blocks**

Supplementary set TM 110.02 extends the scope of experiments which can be performed with TM 110 with the issue comparison of different pulley blocks and their action as "simple machines". The pulley blocks are set up on the panel of unit TM 110.

The line grid on the panel helps to readily determine the force and distance. The pulley blocks are of a robust metal design. Built-in ball and sliding bearings ensure low-friction rotation. The details of the pulley layout and the cable routing are clearly visible.

All parts are clearly laid out and well protected on a storage system. The storage systems are stackable, providing for space-saving storage.

Learning objectives/experiments

- setup and principle of pulley blocks with 4 pulleys and with 6 pulleys; differential pulley block
- principle of "simple machines": force transmission, lifting work and potential energy

Specification

- [1] supplementary set for experimental unit TM 110
- [2] pulley layout and cable routing clearly visible
- [3] pulley blocks: with 4 or 6 pulleys; differential block with roller chain
- [4] cable pulleys made of anodised aluminium ball bearing-mounted
- [5] chain wheels to DIN 8191
- [6] pullers: nylon cord, roller chain
- [7] materials stainless steel or steel, galvanised
- [8] storage system for the components

Technical data**Pullers**

- nylon cord: $\varnothing=2\text{mm}$
- roller chain: 6,0x2,8mm to DIN 8187

Chain wheels

- number of teeth: $z=18, 28, 38$

Cable pulleys

- made of anodised aluminium ball bearing-mounted

LxWxH: 604x404x132mm (storage system)

Weight: approx. 12kg

Scope of delivery

- 1 supplementary set
- 1 storage system with foam inlay
- 1 set of instructional material

TM 110.03**Supplementary set - gear wheels****Learning objectives/experiments**

- transmission ratio of speed and moment on a single-stage gear
- influence of intermediate wheels on the direction of rotation
- transmission ratio on a two-stage gear
- conversion of rotation into linear motion and vice versa

Specification

- [1] supplementary set for experimental unit TM 110
- [2] experiments with single-stage and multistage gears
- [3] aluminium spur wheels with ball bearing mounts
- [4] quick assembly of the elements
- [5] deflection roller, mounting rail and gear wheels made of anodised aluminium
- [6] storage system for the components

Technical data

- Aluminium spur gears
- modulus: $m=2\text{mm}$
 - number of teeth: $z=20, 25, 30, 40, 50, 60$
 - ball bearing gear wheel mounts, secured by thrust pads to grooved pins

Rack

- modulus: $m=2\text{mm}$
- length: $L=300\text{mm}$

- Mounting rail anodised aluminium
- $L \times W \times H$: $760 \times 30 \times 30\text{mm}$

- $L \times W \times H$: $604 \times 404 \times 132\text{mm}$ (storage system)
Weight: approx. 12kg

Scope of delivery

- 1 supplementary set
- 1 storage system with foam inlay
- 1 set of instructional material

Description**mode of operation of single-stage and multistage gears**

Supplementary set TM 110.03 extends the scope of experiments which can be performed with TM 110 with the issues single-stage and multistage gear and conversion of rotation into linear motion. A rack is used to demonstrate the conversion of rotation into linear motion and vice versa.

The base element is an aluminium rail which can be mounted on the panel of TM 110 using clamping elements.

All parts are clearly laid out and well protected on a storage system. The storage systems are stackable, providing for space-saving storage.

TM 115**Forces in a crane jib****Learning objectives/experiments**

- graphical breakdown of forces by force parallelogram
- determination of the bar forces on various jib forms
- comparison of: measuring result – calculation – graphical method

Specification

- [1] tensile and compressive forces in a planar central force system based on the example of a crane jib
- [2] integrated spring balances in the bars
- [3] max. load on crane jib 50N
- [4] stainless steel retaining bar
- [5] sturdy metal base plate
- [6] handles to aid transportation
- [7] storage system to house the components

Technical data

- Spring balance for tensile forces
- tensile force: $0..50\text{N}$
 - graduation: $0,5\text{N}$

- Spring balance for compressive forces
- pressure force: $0..50\text{N}$
 - graduation: 1N

Weights

- 1x 1N (hanger)
- 4x 1N
- 1x 5N
- 4x 10N

- $L \times W \times H$: $600 \times 200 \times 620\text{mm}$
Weight: approx. 10kg
 $L \times W \times H$: $720 \times 480 \times 178\text{mm}$ (storage system)
Weight: approx. 10kg (storage system)

Scope of delivery

- 1 experimental unit
- 2 spring balances
- 1 set of weights
- 1 storage system with foam inlay
- 1 set of instructional material

Description**vectoral handling of forces in a planar central force system**

TM 115 represents a planar central force system in which multiple forces act on a single point of application. Based on the example of a crane jib, forces are determined graphically and experimentally: resultant cable force, tensile force, compressive force. The directions and magnitudes of the forces are determined graphically by way of a force parallelogram.

A bar of adjustable length and a chain make up the crane jib, which is attached by adjustable clamp elements to a retaining bar. Weights are applied to the crane jib. The occurring bar forces are indicated by integrated spring balances.

FL 111

Forces in a simple bar structure



Learning objectives/experiments

- measurement of bar forces
- calculation of bar forces by the method of joints
- comparison: measuring result – calculation – graphical method

Specification

- [1] resolution of forces in a single plane, statically determinate system
- [2] 3 node disks, 2 of which serving as supports
- [3] 3 bars, each fitted with a leaf spring element and dial gauge
- [4] 2 fixed bar lengths, 1 variable bar length
- [5] 5 different angles adjustable between bars
- [6] storage system to house the components

Technical data

Bars

- fixed bar: L=440mm
- adjustable bar: L=440, 622, 762mm

Angle between bars

- 60°-60°-60°/45°-90°-45°
- 30°-120°-30°/30°-30°-120°

Dial gauge

- measuring range: 0...10mm
- graduation: 0,01 mm

Weights

- 1x 1N (hanger)
- 1x 10N
- 2x 20N

Leaf spring element

- force measuring range: 0...50N

LxWxH: 900x200x600mm

Weight: approx. 15kg

LxWxH: 1170x480x178mm (storage system)

Scope of delivery

- 1 frame
- 3 bars
- 3 node disks
- 3 dial gauges
- 1 set of weights
- 1 storage system with foam inlay
- 1 set of instructional material

Description

■ resolution of forces in simple bar structures

The bar forces occurring are measured by the deformation of leaf spring elements in the middle of the bar.

FL 111 represents a simple bar structure. In the single plane system the bars are only subjected to compression and tension. Loads are applied only to the nodes.

The unit comprises three bars that are joined together using disks such that the joints are free to move. A longitudinally adjustable bar permits the bar structure to be constructed with different angles. The bars engage in the disks by snaplocks. Two of the node disks also form the supports (fixed and movable) and are clamped to the sturdy aluminium section base frame. The external load is applied to the upper nodal point by means of weights.

EM 049

Equilibrium of moments on a two-arm lever



Learning objectives/experiments

- fundamentals of the equilibrium of moments: applied forces, generated moments and equilibrium
- action of forces dependent on the lever arm

Specification

- [1] investigation of the equilibrium of moments on a two-arm lever
- [2] ball bearing-mounted beam with integrated scale as two-arm lever
- [3] sturdy metal frame
- [4] storage system to house the components

Technical data

Beam

- LxWxH: 600x30x10mm, centrally ball bearing mounted
- lever length: 2x 300mm

Weights

- 3x 1N (hanger)
- 6x 5N
- 12x 1N

LxWxH: 600x300x410mm

Weight: approx. 10kg

LxWxH: 200x70x40mm (storage system)

LxWxH: 95x68x35mm (storage system)

Scope of delivery

- 1 experimental unit
- 1 set of weights
- 1 set of instructional material

Description

■ fundamentals of the equilibrium of moments and application of the law of levers

A vertical column carries the lever. A sturdy base plate ensures that the unit stands securely.

EM 049 is used to investigate the fundamentals of the equilibrium of moments based on the example of a two-arm lever. Moments occurring on the lever are to be brought to equilibrium.

A centrally mounted beam represents a two-arm lever. Movable riders are placed on the lever and weights are applied. Equilibrium is attained by moving the weights. Distances from the pivot point – the lever arms – can be read from an integrated scale. The calculation of the lever arms is verified in the experiment.

SE 110.53**Equilibrium in a single plane, statically determinate system**

The illustration shows SE 110.53 in the frame SE 112.

Description**■ equilibrium conditions and support reactions of a leaning ladder**

The principle of “freeing” in engineering mechanics allows forces and moments acting on a body to be made visible. In this process, a body or a system such as a bar are virtually removed from the environment. All forces acting on the body or on the system are replaced by standardised symbols. This results in a simplified model of the body or system, which clearly demonstrates the relationships between forces and moments.

In the experiment SE 110.53, we demonstrate the principle of “freeing”, which refers to establishing static equilibrium. The experiment uses a model of a ladder with a sliding clamp weight.

The top support is designed as a movable support and the bottom one as a fixed support. The real effective support forces can be fully compensated by applying cable forces in the x and y directions.

The ladder is in a state of equilibrium without changing the angular position and without the need for structural support. The ladder is “free”. For students, the result is a convincing example for the principle of “freeing” in statics.

The parts of the experiment are clearly laid out and securely housed in a storage system. The entire experimental setup is constructed in the SE 112 mounting frame.

Learning objectives/experiments

- experimental development of the core principle of “freeing” in statics
- calculation of the support forces for a given position of the clamp weight and for a known angle of inclination
- application of the 1st and 2nd equilibrium conditions in statics
- and full compensation of the support forces by cable forces
- how does the clamp weight position affect the support forces
- how the angle of inclination affects the support forces

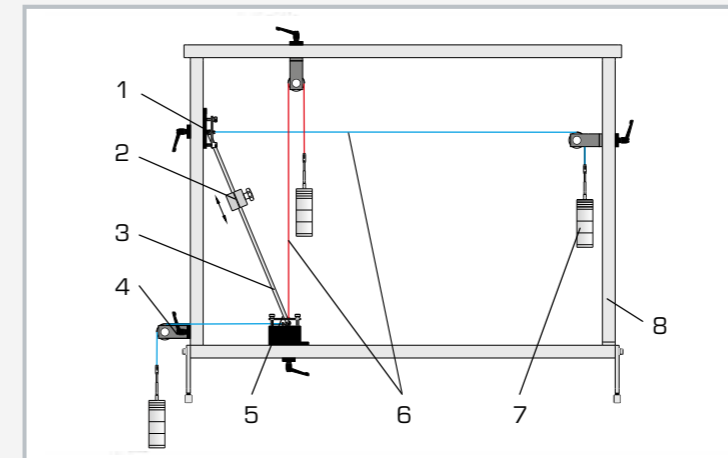

1 support (movable support), 2 clamp weight, 3 ladder, 4 clamp guide pulley, 5 support (fixed support), 6 cable, 7 weight, 8 SE 112 mounting frame

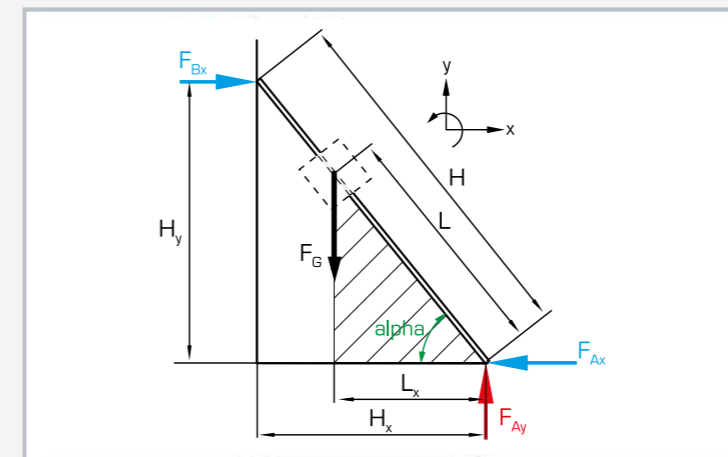

Free-body diagram of the leaning ladder: red: vertical support force, blue: horizontal support force, black: applied force

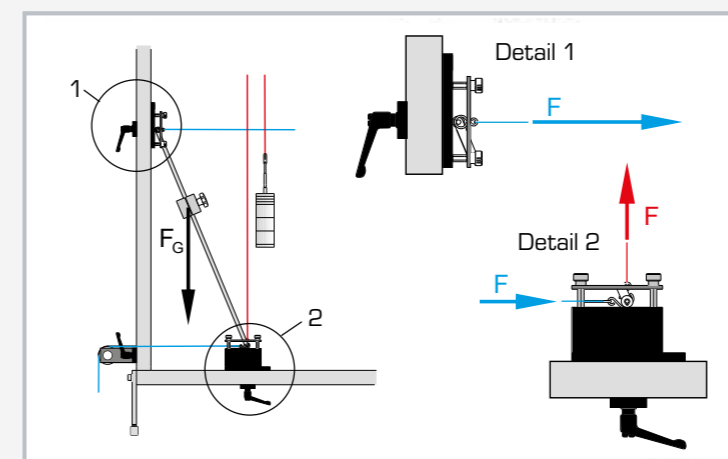
1 movable support, 2 fixed support; F_G applied force; red: cable with weights, compensates the vertical support force, blue: cable with weights, compensates the horizontal support force**Specification**

- [1] development of the static principle of “freeing”
- [2] full compensation of the support forces by cable forces
- [3] sliding clamp weight
- [4] determine the position of the clamp weight via steel rule with millimetre scale
- [5] 2 supports (1x fixed support, 1x movable support)
- [6] 3 guide pulleys
- [7] storage system for parts
- [8] experiment setup in the SE 112 mounting frame

Technical data**Ladder**

- length: 650mm
- weight: 2N
- built-in rule, graduation: 1 mm

Clamp weight: 20N

Weights

- 3x 1N (hanger)
- 9x 5N
- 12x 1N

Supports

- 2, clamped to mounting frame

Steel rule

- length: 1000mm, graduation: 1 mm

LxWxH: 1170x480x178mm (storage system)

Weight: approx. 28kg (total)

Scope of delivery

- 1 model of a ladder
- 2 supports
- 3 guide pulleys
- 1 set of weights
- 1 clamp weight
- 3 cables
- 1 steel rule
- 1 storage system with foam inlay
- 1 set of instructional material

TM 121

Equilibrium of moments on pulleys



Learning objectives/experiments

- fundamentals of the equilibrium of moments: acting forces, generated moments and equilibrium
- effect of forces as a function of pulley diameter

Specification

- [1] investigation of the equilibrium of moments on two pulleys
- [2] anodised aluminium pulleys
- [3] ball bearing-mounted steel shaft
- [4] storage system for parts
- [5] bracket for wall mounting

Technical data

Pulleys

- $\varnothing=75\text{mm}$
- $\varnothing=150\text{mm}$

Weights

- 2x 1N (hanger)
- 4x 0,5N
- 4x 1N
- 4x 2N
- 4x 5N

Base plate, WxH: 200x250mm

LxWxH: 250x200x250mm
Weight: approx. 13kg
LxWxH: 290x140x130mm (storage system)

Scope of delivery

- 1 experimental unit
- 1 set of weights
- 2 cables
- 1 set of instructional material

Description

■ memorable demonstration of the equilibrium of moments

The TM 121 experimental unit illustrates the laws for forming the equilibrium of moments in static systems. The relations between wheel diameter, moment and circumferential force are demonstrated.

Two pulleys with different diameters are mounted on a steel shaft, which is itself mounted on ball bearings.

Weights can be hung on the cables, making it possible to represent different load cases acting on two pulleys with different diameters. The forces can be varied using weights until equilibrium is reached.

The experimental unit is designed to be fixed to a wall. The parts of the experiment are clearly laid out and securely housed in a storage system.

TM 122

Equilibrium of moments on a differential pulley block



Learning objectives/experiments

- fundamentals of the equilibrium of moments: acting forces, generated moments and equilibrium
- relation between power savings and cable route

Specification

- [1] investigation of the equilibrium of moments on a differential pulley block
- [2] anodised aluminium pulleys
- [3] 1 loose roller
- [4] ball bearing-mounted steel shaft
- [5] bracket for wall mounting

Technical data

Pulleys

- $\varnothing=250\text{mm}$
- $\varnothing=100\text{mm}$
- $\varnothing=50\text{mm}$

Loose roller

- $\varnothing=75\text{mm}$

Weights

- 2x 1N (hanger)
- 4x 0,5N
- 4x 1N
- 4x 2N
- 4x 5N

Base plate, WxH: 300x250mm

LxWxH: 300x280x250mm
Weight: approx. 14kg

Scope of delivery

- 1 experimental unit
- 1 set of weights
- 2 cables
- 1 set of instructional material

Description

■ demonstration of power savings on the differential pulley block

The TM 122 experimental unit illustrates the equilibrium conditions on a differential pulley block. The relation between pulley diameter, lifting force and torque is demonstrated.

Three pulleys with different diameters are mounted on a shaft, which is itself mounted on ball bearings. Weights can be hung on the cables.

The forces act on the one hand directly on the periphery of the pulley with the largest diameter and another force acts on the pulley with the smaller diameter via a loose roller. Using weights, it is possible to vary these forces until equilibrium is reached.

The experimental unit is designed to be fixed to a wall.

Basic knowledge

Internal reactions and methods of sections for bars, beams and cables

The support structures are composed of different structural supporting elements. The supporting elements are divided into one-dimensional (bar or beam), two-dimensional (plate or disk) and three-dimensional elements (solid-supporting structure).

To investigate internal reactions in components or mechanical systems, these are reduced to a few important properties through modelling. Geometric idealisation then eliminates seemingly insignificant dimensions. Instead of three-dimensional supporting elements, two-dimensional supporting

elements/plane-supporting structures (plates, disks and frames) and one-dimensional supporting elements/linear structures (beams, bars, arches and cables) are considered. In this chapter, we look at one-dimensional supporting structural elements.

One-dimensional supporting elements

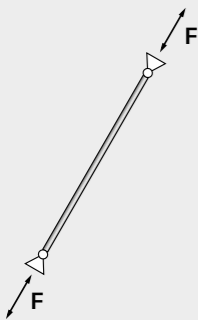

Bar: A support element, flexibly mounted at both ends, which can transfer tensile and compressive forces along the bar axis. Depending on whether a bar transfers tensile or compressive forces, it is referred to as a tension bar or a compression bar.

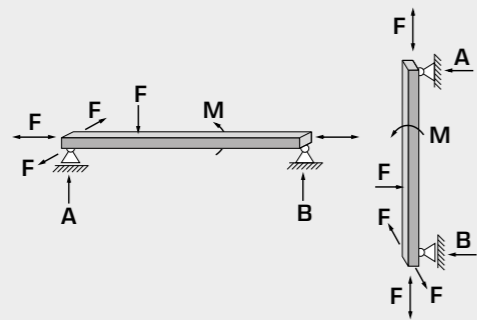

Beam: Rectilinear supporting element that can transfer forces along its axis, transverse to its axis and moments. Horizontal elements are generally known as beams or girder and vertical elements are known as pillars or columns.

F forces, M bending moment, A, B support forces

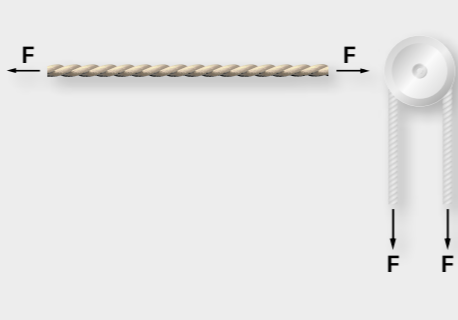

Cable: A support element that can only transfer tensile forces. A cable that is attached at two defined points is the equivalent of a tension bar.

Internal forces

Using notional sections, parts are cut out of the support structure, which is in equilibrium. To maintain equilibrium, the internal reactions, also known as section reactions or internal forces, are entered into the sections. In statics, the internal reactions

show the forces and moments within a component as a reaction to the action of the external forces.

Normal force

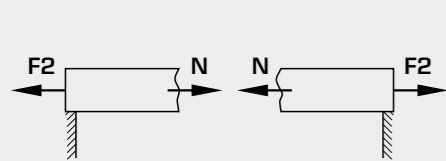

The normal force runs in the direction of the beam axis. This force causes a change in the beam length through an internal reaction to tensile or compressive external forces acting on the beam.

Shear force

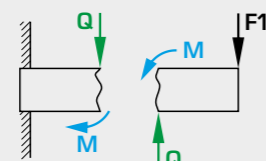

The shear force is perpendicular to the normal force. This force results in shear deformation and is the beam's internal reaction to the acting transversal forces.

Bending moment

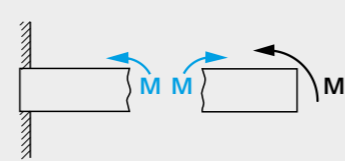

The bending moment runs around the centroid of the section. This moment causes the beam to bend as a reaction to (tensile and compressive) forces acting on the beam from the outside.

F1 force, F2 tensile force, M bending moment, N normal force, Q shear force

Free-body diagrams are the main method to represent the internal force states in bars, beams and cables. For beam-structures in particular, free-body diagrams are used to characterise the internal stress state and, consequently, are used when dimensioning the beam. Considering the internal forces is a prerequisite for calculating deformation and investigating

the load-bearing capacity of materials as a measure of their strength. When designing components, the internal forces provide the designer with the crucial indicators for necessary dimensions or the type of load distribution.

Internal reactions

1. The studied bodies or mechanical systems are removed from the environment through representation in the **free-body diagram**.

2. All forces acting on the body or system are determined. Especially where the body or the mechanical system under investigation is separated from adjacent bodies. Since the internal forces change between the different cross-sections, we plot their curves for a better overview. The shear force, normal force and bending moment are represented as areas.

3. Unknown forces are calculated using the equilibrium conditions.

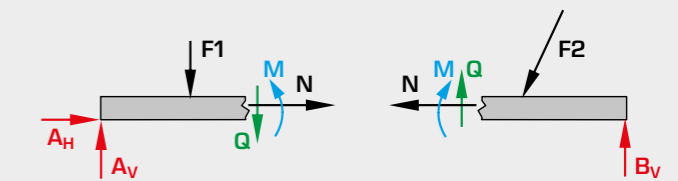
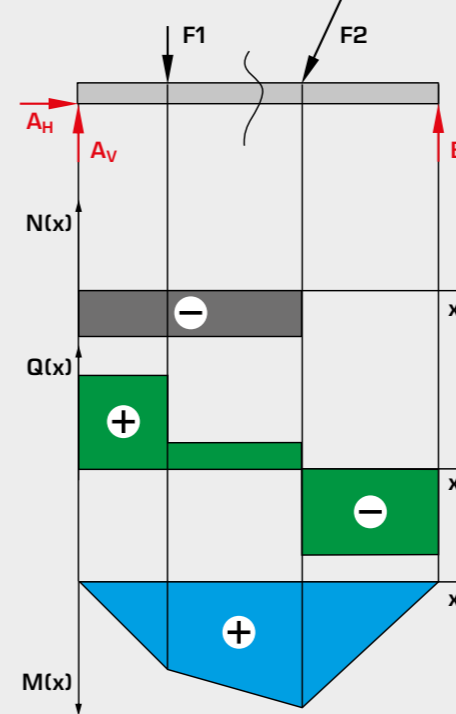
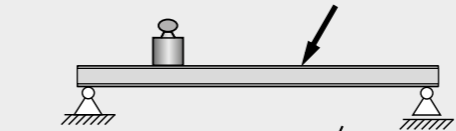

Supporting structure

Internal forces on a beam

N normal force, Q shear force, M bending moment, F external forces, A, B support forces (support reactions)

Equilibrium condition

A body or a mechanical system is in equilibrium when the effects of all applied forces and moments cancel each other out.

$$\sum F = 0 \quad \sum M = 0$$

WP 960**Beam on two supports: shear force & bending moment diagrams****Description**

- application of the method of sections to determine internal reactions of the beam
- direct indication of shear force and bending moment at a section on the beam

Statics observes the effect of forces on a rigid body, ignoring any possible deformations which may occur in the process. The forces are in equilibrium.

A simple example is a statically determinate bearing-mounted beam subjected to point loads. The reactions are determined from the conditions of equilibrium. To investigate the effect of the point loads in the beam, it is notionally split into two segments. Applying the method of sections, the internal forces and moments are plotted onto the two segments and calculated by way of conditions of equilibrium.

WP 960 includes a beam mounted on two supports. The beam is cut at one point. At that point there is a low-friction hinge with two degrees of freedom. Two force gauges determine the internal reactions to the externally applied forces at the section. The shear force is recorded and displayed directly by a force gauge.

The bending moment occurring at the section is recorded by a second force gauge acting on a fixed lever arm. This force readout, divided by 10, gives the bending moment in Nm. Adjuster nuts on the two force gauges are used to align the beam horizontally and balance out any deflection.

In evaluating the experiment it becomes clear that the shear force, as opposed to the bending moment, is mostly negligible when designing components.

The various elements of the experiment are clearly laid-out and housed securely in a storage system. The complete experimental setup is arranged on a frame.

Learning objectives/experiments

- calculation of the reactions arising from the static conditions of equilibrium
- application of the method of sections to calculate the internal forces and moments
 - ▶ under a point load
 - ▶ under multiple point loads
- calculation of the shear force diagram
- calculation of the bending moment diagram
- comparison of calculated and measured values for shear force and bending moment

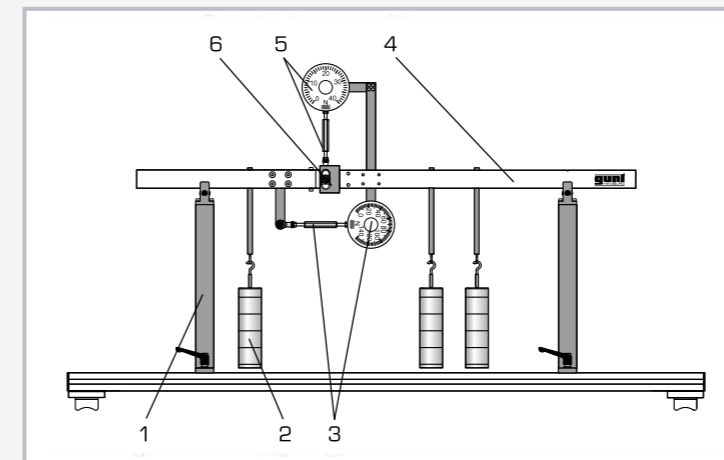

1 beam support, 2 weight, 3 force gauge with adjuster nut to determine the bending moment, 4 beam, 5 force gauge with adjuster nut (shear force), 6 hinge with 2 degrees of freedom

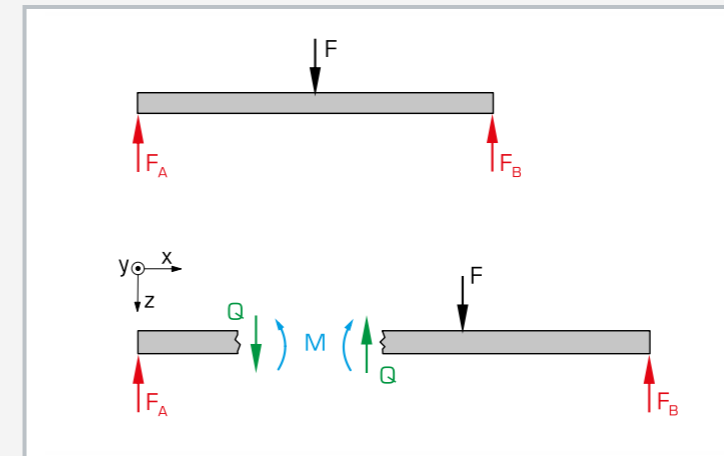

Internal forces on the beam under mid point load:
F applied point load, F_A/F_B reactions ($0,5F$), Q shear force, M bending moment

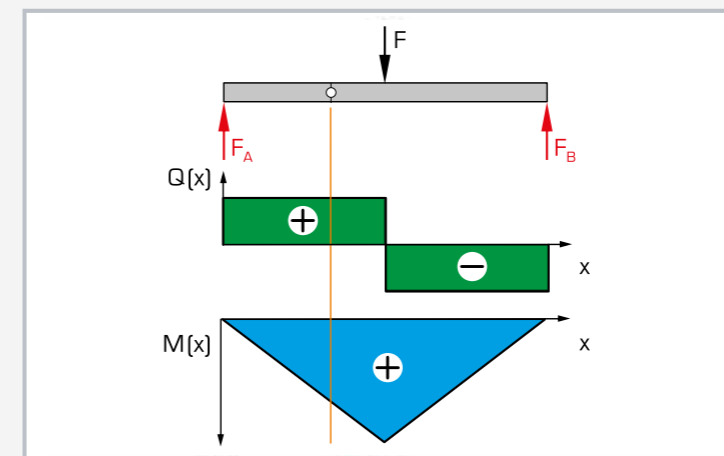

Shear force and bending moment diagram on beam with mid point load:
line (orange): position of the hinge at which the internal forces of the beam are indicated

Specification

- [1] determination of shear force and bending moment on beam mounted on 2 supports
- [2] measurement of shear force and bending moment in beam by low-friction hinge with 2 degrees of freedom
- [3] position of hinge at $1/3$ span
- [4] 2 bearing supports
- [5] loading of beam by 1 to 3 point loads
- [6] force gauges to indicate shear force and determine bending moment
- [7] bending moment determined by force measurement and lever arm
- [8] adjuster nuts for horizontal alignment of beam
- [9] steel rule to determine positions of point loads
- [10] storage system to house the components

Technical data**Beam**

- total length: 1000mm
- span: 800mm

Weights

- 3x 1N (hanger)
- 12x 1N
- 9x 5N
- max. weight per hanger: 20N

Measuring ranges

- bending moment via force gauge and lever arm
 - ▶ lever arm: 100mm
 - ▶ force gauge: $\pm 100\text{N}$
 - ▶ bending moment: $\pm 10\text{Nm}$
- shear force: $\pm 50\text{N}$
- steel rule: 1000mm, graduation: 1mm

LxWxH: 1400x320x600mm

Weight: approx. 35kg

LxWxH: 1170x480x178mm (storage system)

Weight: approx. 12kg (storage system)

Scope of delivery

- 1 experimental unit
- 1 set of weights
- 1 set of accessories
- 1 storage system with foam inlay
- 1 set of instructional material

WP 961

Beam on two supports: shear force diagram



Learning objectives/experiments

- calculation of the reactions arising from the static conditions of equilibrium
- application of the method of sections to calculate the internal forces
 - ▶ under a point load
 - ▶ under multiple point loads
- calculation of the shear force diagram
- comparison of calculated and measured shear force values

Specification

- [1] investigation of shear force on beam mounted on 2 supports
- [2] measurement of shear force in beam by low-friction hinge with 1 degree of freedom
- [3] position of hinge at 1/3 span
- [4] 2 bearing supports
- [5] loading of beam by 1 to 3 point loads
- [6] force gauge to indicate shear force
- [7] adjuster nut for horizontal alignment of beam
- [8] storage system to house the components

Technical data

- Beam
- total length: 1000mm
 - span: 800mm

Shear force measuring range: $\pm 50\text{N}$

Weights

- 3x 1N (hanger), 12x 1N, 9x 5N
- max. weight per hanger: 20N

LxWxH: 1400x320x600mm
 Weight: approx. 35kg
 LxWxH: 1170x480x178mm (storage system)
 Weight: approx. 12kg (storage system)

Scope of delivery

- 1 experimental unit
- 1 set of weights
- 1 set of accessories
- 1 storage system with foam inlay
- 1 set of instructional material

Description

■ application of the method of sections to determine the shear force

WP 961 consists of a beam mounted on two supports which is subjected to point loads. The beam is cut at one point. At that point there is a low-friction hinge with one degree of freedom. The force gauge indicates the internal reaction (shear force) at this point on the beam. An adjuster nut on the force gauge is used to align the beam horizontally and balance out any deflection.

The reactions are determined from the static conditions of equilibrium. To investigate the effect of the point loads in the beam, it is notionally split into two segments. Applying the method of sections, the internal forces and moments are plotted onto the two segments and calculated by way of conditions of equilibrium.

WP 962

Beam on two supports: bending moment diagram

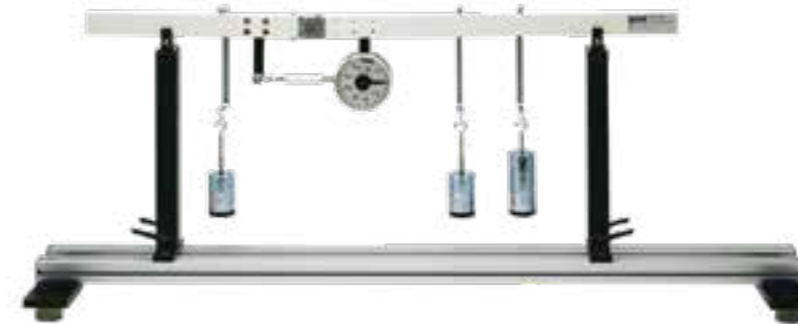

Learning objectives/experiments

- calculation of the reactions arising from the static conditions of equilibrium
- application of the method of sections to calculate the internal moments
 - ▶ under a point load
 - ▶ under multiple point loads
- calculation of the bending moment curve
- comparison of calculated and measured bending moment values

Specification

- [1] investigation of bending moment on beam mounted on 2 supports
- [2] indication of bending moment in beam by low-friction hinge with 1 degree of freedom
- [3] position of hinge at 1/3 span
- [4] 2 bearing supports
- [5] loading of beam by 1 to 3 point loads
- [6] force gauge and lever arm to indicate bending moment
- [7] adjuster nut for horizontal alignment of beam
- [8] storage system to house the components

Technical data

- Beam
- total length: 1000mm
 - span: 800mm

Bending moment measuring range: $\pm 10\text{Nm}$

Weights

- 3x 1N (hanger), 12x 1N, 9x 5N
- max. weight per hanger: 20N

LxWxH: 1400x320x600mm
 Weight: approx. 35kg
 LxWxH: 1170x480x178mm (storage system)
 Weight: approx. 12kg (storage system)

Scope of delivery

- 1 experimental unit
- 1 set of weights
- 1 set of accessories
- 1 storage system with foam inlay
- 1 set of instructional material

Description

■ application of the method of sections to determine the bending moment

WP 962 consists of a beam mounted on two supports which is subjected to point loads. The beam is cut at one point. At that point there is a low-friction hinge with one degree of freedom. The bending moment occurring at the section is recorded by a force gauge acting on a fixed lever arm. An adjuster nut on the force gauge is used to align the beam horizontally and balance out any lowering.

The reactions are determined from the static conditions of equilibrium. To investigate the effect of the point loads in the beam, it is notionally split into two segments. Applying the method of sections, the internal forces and moments are plotted onto the two segments and calculated by way of conditions of equilibrium.

SE 110.50

Cable under dead-weight



The illustration shows SE 110.50 in the frame SE 112.

Description

■ catenary of a free-hanging cable under dead-weight

Free-hanging cables and ropes are often used to support a structure, such as stay cables. On suspension bridges they are the load-bearing element of the structure. In many calculations the influence of the dead-weight of the cable can be ignored, because it is low compared to the other loads. In the case of overhead power lines, however, the dead-weight of the cable is relevant to the design of the pylons.

In SE 110.50 a free-hanging cable under the influence of its own dead-weight is investigated. A roller chain serves as the cable, and is mounted on two ball bearing-supported chain wheels. The chain wheel units are fixed to a cross-arm. The spacing between the chain wheel axles can be adjusted horizontally and vertically. Weights can be attached to both ends of the chain. The maximum sag is measured using scaled rules, and can be compared with calculated values. The sag is the distance between the connecting line of the supports and the catenary (see also illustration: "Actual applied cable forces" on the next page).

All the component elements of the experiment are clearly laid-out and housed securely in a storage system. The complete experimental setup is arranged in the frame SE 112.

Learning objectives/experiments

- determination of the catenary of a free-hanging cable
 - ▶ under dead-weight only
 - ▶ with additional weights
 - ▶ with a symmetrical setup (chain wheels at same height)
 - ▶ with an unsymmetrical setup
- measurement of the sag
- comparison of calculated and measured values

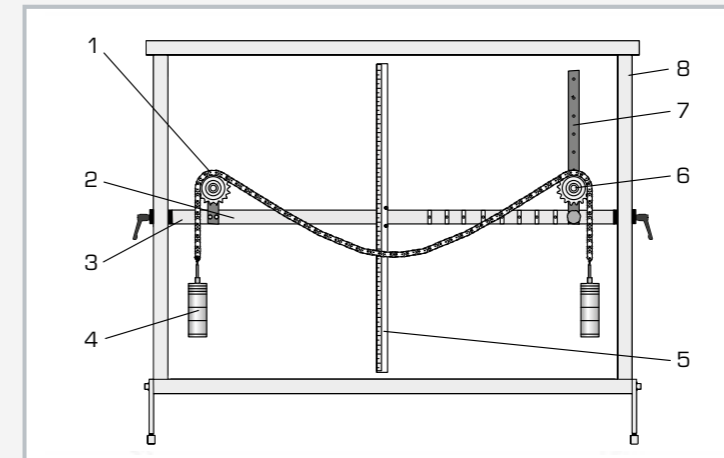

1 roller chain, 2 cross-arm with scale, 3 clamp, 4 weight, 5 rule, 6 chain wheel, 7 chain wheel holder, 8 frame SE 112

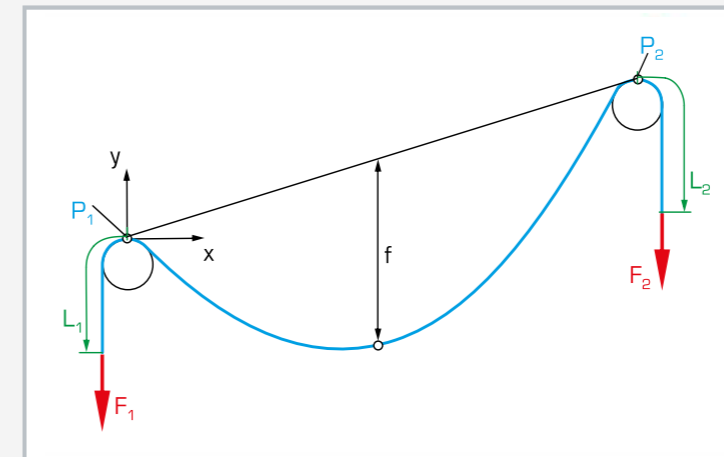

Actual applied cable forces: $F_1 + F_2$ forces, $L_1 + L_2$ suspended chain length with dead-weight, $P_1 + P_2$ marker point on chain wheel, f sag



Free-hanging cables in practice (portal): 1 stay cable, 2 power line, similar to overhead line

Specification

- [1] determination of the catenary of a free-hanging cable
- [2] symmetrical and unsymmetrical experimental setup possible
- [3] roller chain as cable with 2 ball bearing-mounted chain wheels
- [4] adjustable chain wheel axle spacing
- [5] height of a chain wheel adjustable for unsymmetrical experimental setup
- [6] cross-arm with scale to hold chain wheels and rule to measure vertical sag of chain
- [7] 2 hangers to load the ends of the chain
- [8] storage system to house the components
- [9] experimental setup in frame SE 112

Technical data

Roller chain
 ■ DIN 8187
 ■ length: 2400mm
 ■ weight: 0,95kg/m

Chain wheel, number of teeth: 17

Cross-arm
 ■ axle base: 600...1000mm
 ■ groove spacing: 50mm

Holder
 ■ adjustable height of chain wheel: 0...300mm
 ■ hole spacing: 50mm

Weights
 ■ 2x 1N (hanger)
 ■ 8x 1N
 ■ 6x 5N

Measuring ranges
 ■ horizontal: 0...1000mm
 ■ vertical: 0...850mm
 ■ graduation: 1mm

LxWxH: 1170x480x178mm (storage system)
 Weight: approx. 29kg (total)

Scope of delivery

- 1 roller chain
- 1 cross-arm with clamp
- 2 chain wheels with holders
- 1 rule
- 1 set of weights
- 1 storage system with foam inlay
- 1 set of instructional material

Basic knowledge Method of sections for plane trusses

Plane trusses are structures that only comprise straight bars. The bars are connected to nodes. To determine the support reactions and the forces and moments that are transferred to the nodes, we first make idealising assumptions:

1. The bars are connected to each other at the nodes, centrally and flexibly.
2. The external forces only act on the nodes.

These requirements for an ideal truss ensure that all bars are only subjected to tension or pressure. The support forces and bar forces are calculated using various methods of sections.

Method of joints

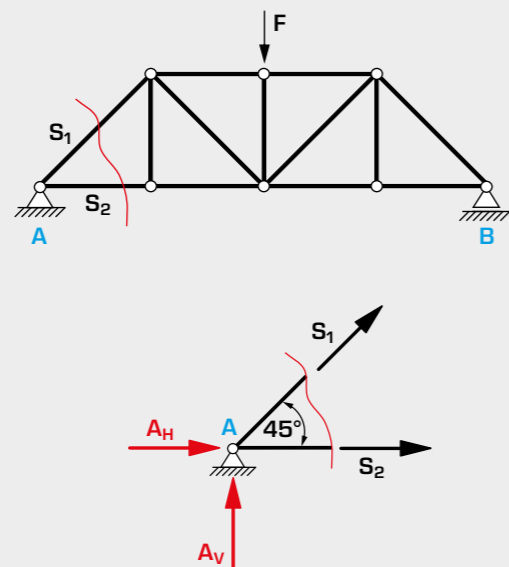

S bar forces, A+B support forces, F forces, index V vertical forces, index H horizontal forces

Using the method of joints, all nodes are isolated in succession. The equilibrium conditions are established at each node. Applying the method of joints requires that no more than two unknown forces are acting on the node. The advantage of this method is that no bar force is overlooked in complex trusses.

Equilibrium condition	$\sum F_V = 0 = A_V + S_1 \sin 45^\circ$ $\sum F_H = 0 = S_2 + S_1 \cos 45^\circ + A_H$
-----------------------	---

Ritter's method of sections

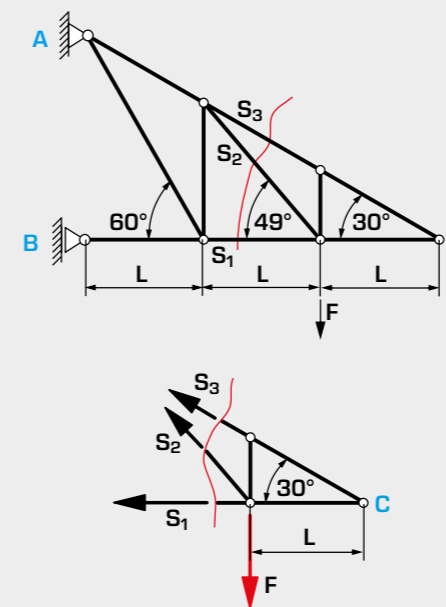

S bar forces, A+B support forces, C nodes, F force, L bar length, S2 wanted bar force

Ritter's method of sections is used when only single bar forces need to be determined in a truss. Applying Ritter's method of sections requires that the supporting and external forces are known. The section runs through three bars, of which two bars are connected in a node. In the case of the equilibrium of moments, it makes sense to choose the intersection of the two bar forces as the reference point. Consequently, only one unknown bar force remains in the equation. The advantage of this method is that it is possible to calculate individual bar forces without having to consider every node.

Equilibrium condition	$\sum F_V = 0 = -F + S_2 \sin 49^\circ + S_3 \sin 45^\circ$ $\sum F_H = 0 = -S_3 \cos 30^\circ - S_1 - S_2 \cos 49^\circ$ $\sum M_C = F \cdot L - S_2 \cdot \sin 49^\circ \cdot L = 0$
-----------------------	--

Cremona diagram (forces diagram)

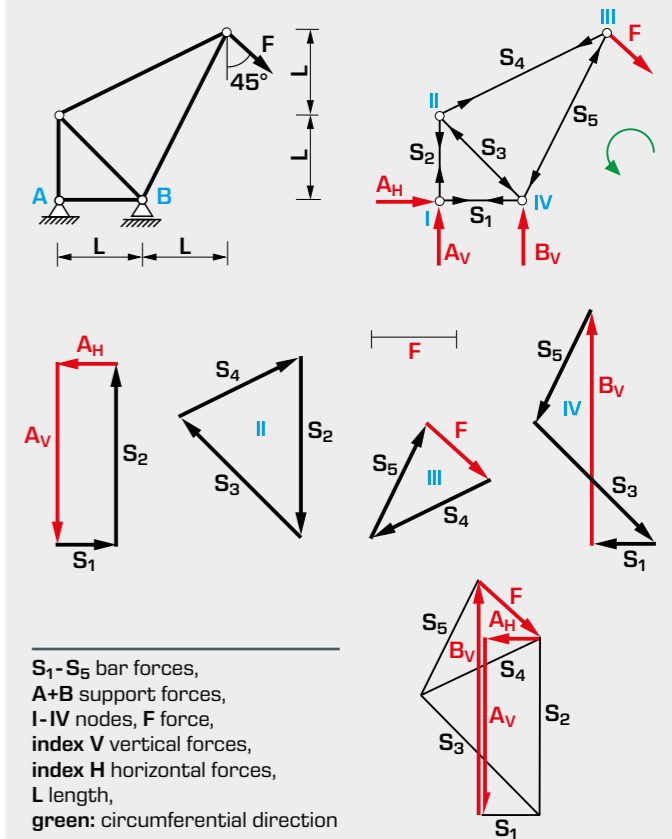

S₁-S₅ bar forces, A+B support forces, I-IV nodes, F force, index V vertical forces, index H horizontal forces, L length, green: circumferential direction

The Cremona diagram is a graphical method for determining bar forces in a truss. Applying the Cremona diagram requires that the support forces and the external forces are known or that they have been determined beforehand using the method of joints. Then a force diagram is systematically plotted for each node with a known force and two unknown forces. The direction of force is plotted in the entire force diagram of the truss. The unknown bar forces can be derived from the triangle of forces. The advantage of this method is that no bar force is overlooked in complex trusses and all force directions are correctly plotted.

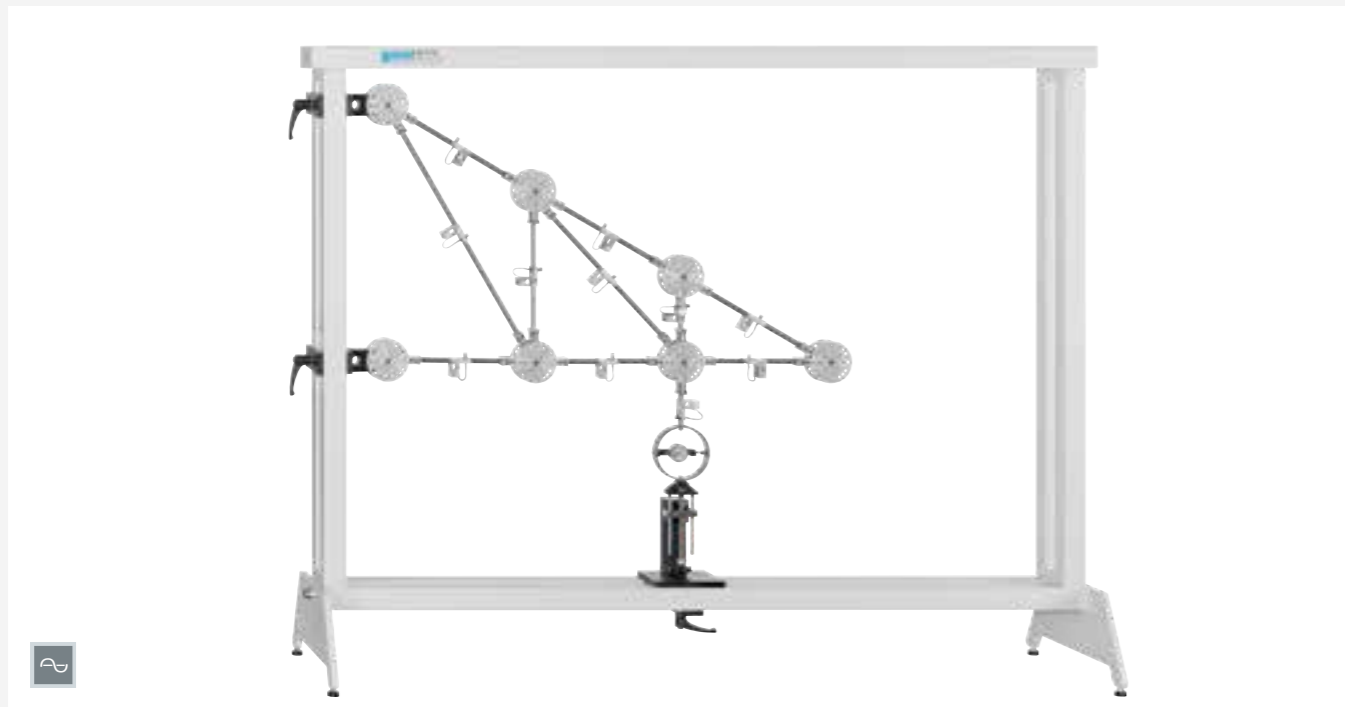
SE 110.21**Forces in various single plane trusses**

The illustration shows SE 110.21 in the frame SE 112.

Description

- measurement of the bar forces in a single plane truss
- construction of various truss forms
- bars with strain gauge measurement to measure bar force

As light-weight structures offering a high degree of rigidity, trusses are employed in the construction of halls, bridges, cranes, pylons and masts. Trusses are bar structures in which the bars are subjected to compression or tension loading, but not to bending.

The object of the experiment is to measure the bar forces in a single plane truss subjected to a single external force. The SE 110.21 experimental setup features bars with special snap-lock closures on their ends allowing them to be fixed easily into the node disk. The range of different bar lengths provided permits three statically determinated truss to be constructed.

The bars are hinged, joined together by node disks, and are subjected only to compressive or tensile stress. No moments are transmitted in the nodes; they can be regarded as frictionless.

Consequently, our trusses can be considered as ideal trusses. A load application device attached to a node disk generates an external force. All the forces on the truss bars are recorded by means of strain gauge measurement. Computerised evaluation of the measured values is provided by measuring amplifier FL 152 (16 input channels). The software in FL 152 is used to manage the measured data and provide graphical representation of the bar forces. The software features a comprehensive help function.

All the component elements of the experiment are clearly laid-out and housed securely in a storage system. The complete experimental setup is arranged in the frame SE 112.

Learning objectives/experiments

- measurement of the bar forces in various single plane trusses
- dependency of the bar forces on the external force
 - ▶ magnitude
 - ▶ direction
 - ▶ point of application
- comparison of measuring results with mathematical methods
 - ▶ method of joints
 - ▶ Ritter's method of sections
- basic principle: measurement of forces using strain gauge measurement

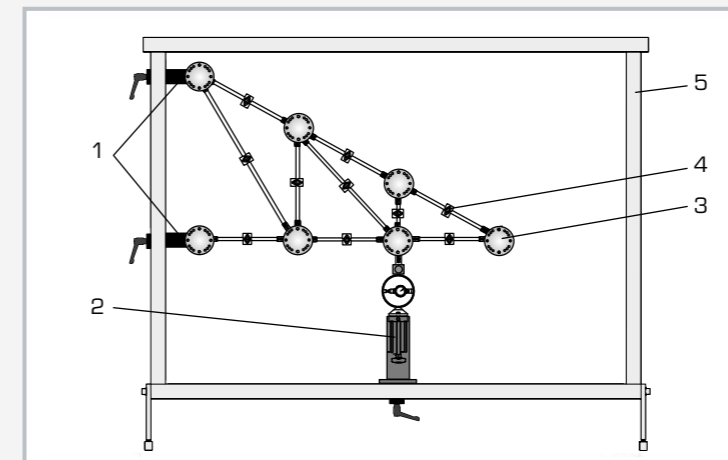

1 support, 2 load application device with force gauge, 3 node disk, 4 bar with measuring point, 5 frame SE 112

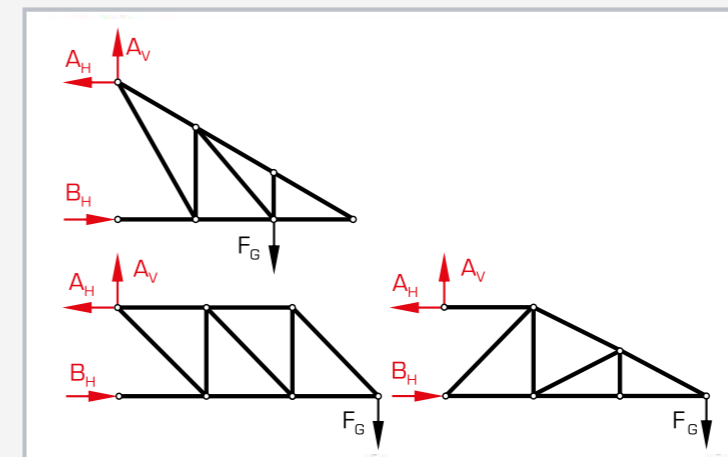
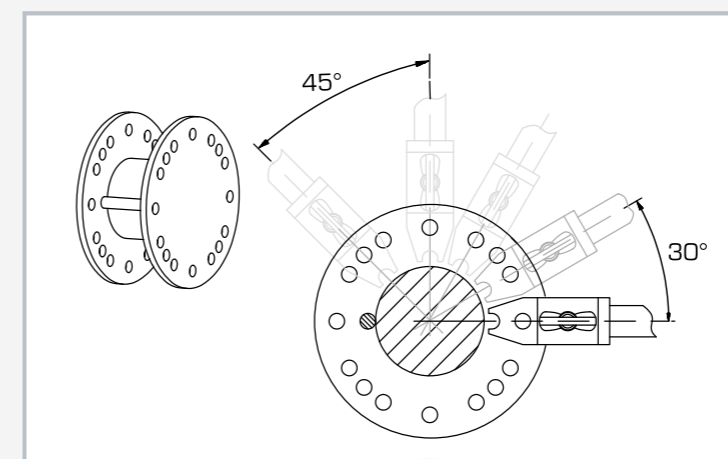
3 truss forms
red: support reactions, black: external force

Fixing of the bars in the node disk

Specification

- [1] investigation of bar forces in a statically determinate truss
- [2] construction of various trusses possible
- [3] 2 supports with node disks
- [4] load application device with force gauge mountable on different node disks
- [5] measuring points to measure force on each bar
- [6] measuring amplifier FL 152 required
- [7] GUNT-software in FL 152 to evaluate measured values graphically
- [8] storage system to house the components
- [9] experimental setup in frame SE 112

Technical data

Bars: 19

- 2 bars 150mm
- 5 bars 259mm
- 7 bars 300mm
- 1 bar 397mm
- 3 bars 424mm
- 1 bar 520mm
- angle between bars: 30°, 45°, 60°, 90°
- maximum bar force: 500N
- measuring points on each bar
- height of truss max. 450mm
- length of truss max. 900mm

Load application device

- ±500N
- graduation: 10N

LxWxH: 1170x480x178mm (storage system)

Weight: approx. 26kg (total)

Scope of delivery

- 1 set of bars
- 5 node disks
- 2 supports with node disk
- 1 load application device
- 1 set of cables
- 1 storage system with foam inlay
- 1 set of instructional material

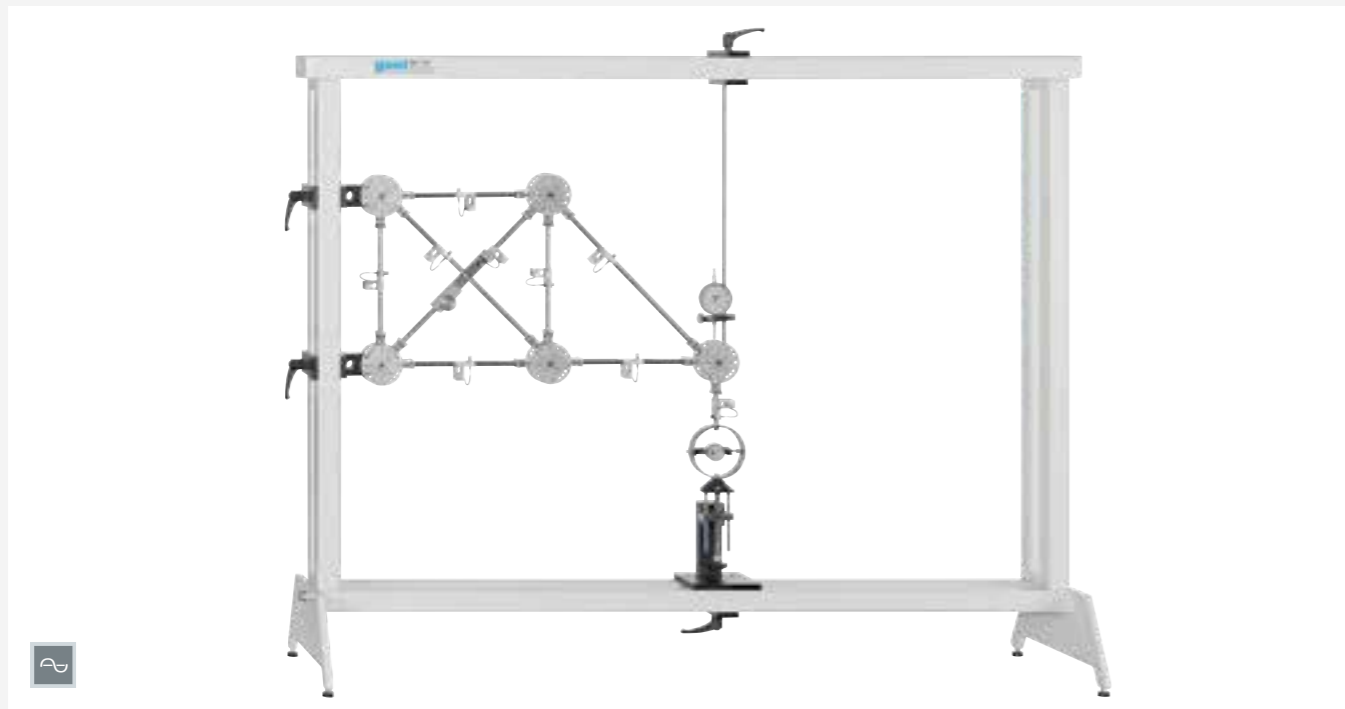
SE 110.22**Forces in an overdeterminate truss**

The illustration shows SE 110.22 in the frame SE 112.

Description

- **comparison of forces in statically determinate and overdeterminate trusses**
- **bars with strain gauge measurement to measure bar force**

With surplus bars a statically determinate truss becomes internally statically indeterminate. In this case the truss is termed statically overdeterminate. In an overdeterminate truss, the bar forces depend on the elastic properties of the truss and cannot be calculated easily.

The SE 110.22 experimental setup permits investigation and comparison of statically determinate and statically indeterminate trusses.

Using the bars and node disks, a statically determinate, single plane truss is first constructed. On installation of a surplus bar the truss becomes overdeterminate. By way of a load application device, straight or inclined forces are applied to the truss, thereby simulating various load cases. The occurring tensile and compressive forces in the bars are recorded by means of strain gauge measurement.

Computerised evaluation of measured values is provided by measuring amplifier FL 152. The software in FL 152 is used to manage the measuring data and provide graphical representation of the bar forces. The software features a comprehensive help function.

All the component elements of the experiment are clearly laid-out and housed securely in a storage system. The complete experimental setup is arranged in the frame SE 112.

Learning objectives/experiments

- measurement of the bar forces in a statically determinate and a statically overdeterminate, single plane truss
- distribution of forces in the single plane truss dependent on the use of a surplus bar
- dependency of the bar forces on the external force
 - ▶ magnitude, direction, point of application
- comparison of measuring results with mathematical methods
 - ▶ method of joints
 - ▶ Ritter's method of sections
- basic principle: measurement of forces using strain gauge measurement

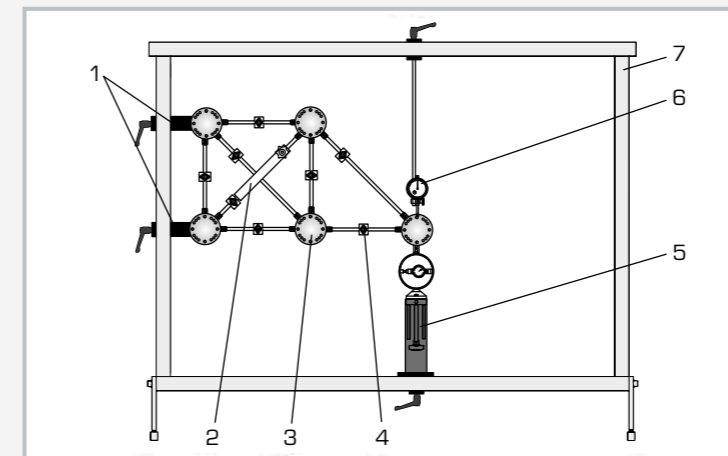

1 support, 2 surplus bar (adjustable), 3 node disk, 4 bar with measuring point, 5 load application device, 6 dial gauge with fixture, 7 frame SE 112

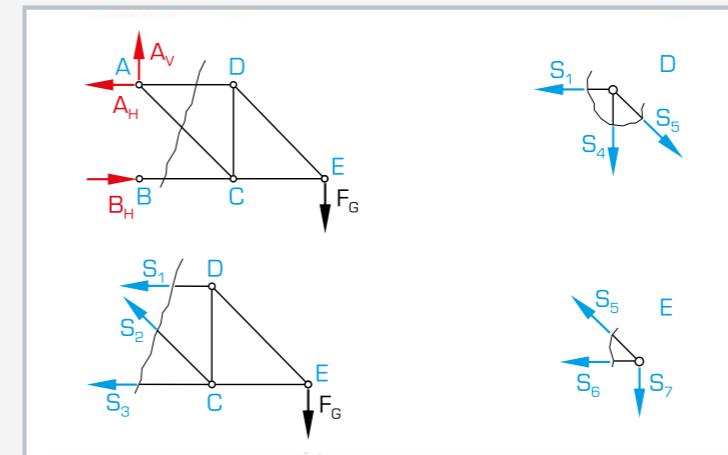
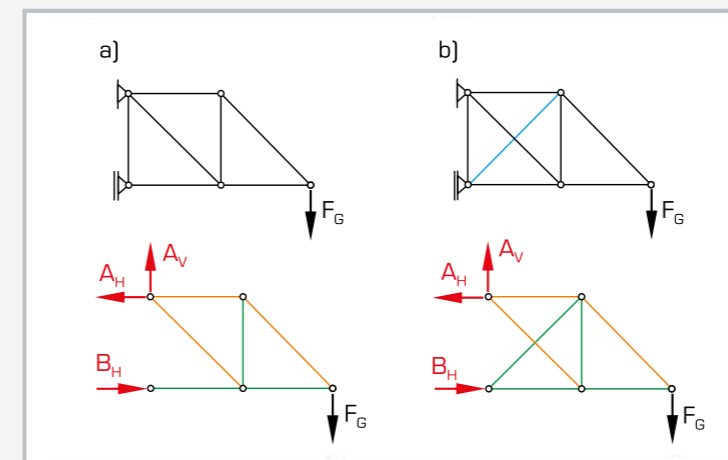
Free-body diagram of truss, Ritter's method of sections:
A, B, C, D, E: nodes, black: applied force, red: support reactions,
blue: S_1 - S_7 bar forcesa) statically determinate truss, b) statically overdeterminate truss;
red: support reactions, black: applied force, blue: surplus bar, green: compression bars (struts), orange: tension bars (ties)**Specification**

- [1] investigation of bar forces in statically overdeterminate trusses
- [2] surplus bar, longitudinally adjustable
- [3] straight and inclined loading possible
- [4] load application device with force gauge mountable on different node disks
- [5] measuring point to measure force on each bar
- [6] measuring amplifier FL 152 required
- [7] GUNT-software in FL 152 to evaluate measured values graphically
- [8] storage system to house the components
- [9] experimental setup in frame SE 112

Technical data

Bars: 8

- 5 bars, fixed 300mm
- 2 bars, fixed 424mm
- 1 bar, adjustable 400...450mm
- angle between bars: 30°, 45°, 60°, 90°
- maximum bar force: 500N
- measuring point on each bar
- height of truss max. 270mm
- length of truss max. 500mm

Load application device

- ±500N
- graduation: 10N

Dial gauge: measuring range: 0...20mm

LxWxH: 1170x480x178mm (storage system)

Weight: approx. 22kg (total)

Scope of delivery

- 1 set of bars
- 5 node disks
- 1 load application device
- 1 dial gauge
- 1 set of cables
- 1 storage system with foam inlay
- 1 set of instructional material

SE 130

Forces in a Howe truss



Description

- measurement of bar forces on a single plane truss, Howe type
- measurement of bar forces by strain gauge measurement
- external load may be applied at different angles

As light-weight structures offering a high degree of rigidity, trusses are employed in the construction of halls, bridges, cranes, pylons and masts. Trusses are bar structures in which the bars are subjected to compression or tension loading, but not to bending.

The SE 130 setup provides experiments on single plane trusses with a high degree of measuring accuracy and computerised result readout based on software. The ready assembled truss is mounted horizontally on a frame. The influence of the dead weight is minimized by horizontal experimental setup. The bars are joined by a "hinged" connection, using node disks. Consequently, our truss can be considered as an ideal truss. The external force is generated with the aid of a threaded spindle. The force can be applied in various directions and at various points.

The forces occurring on the truss bars are recorded by strain gauge measurement. All measuring points are housed together in a connection box. From there, they are connected to the measuring amplifier FL 152. The software is used to manage the measuring data and provide graphical representation of the bar forces. The software features a comprehensive help function.

An additional truss is available to extend the scope of the experiment: SE 130.01, Warren type.

Learning objectives/experiments

- measurement of the bar forces in a single plane truss, Howe type
- dependency of bar forces on the external force
 - ▶ magnitude, direction, point of application
- comparison of measuring results with mathematical and graphical methods
 - ▶ method of joints
 - ▶ Ritter's method of sections
 - ▶ Cremona diagram
- basic principle: measurement of forces using strain gauge measurement

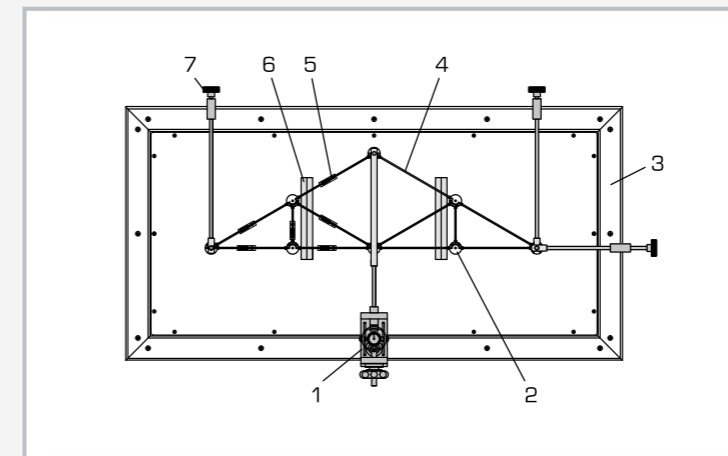

1 load application device with force gauge, 2 node disk, 3 frame, 4 bar, 5 measuring point on bar, 6 knife-edge bearing, 7 adjuster screw

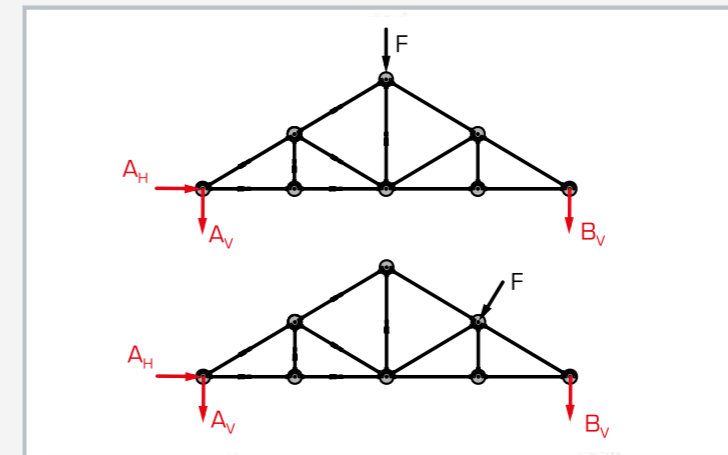

Load case, top: weight loading on ridge, load case, bottom: wind load perpendicular to roof, black: applied force, red: support reactions

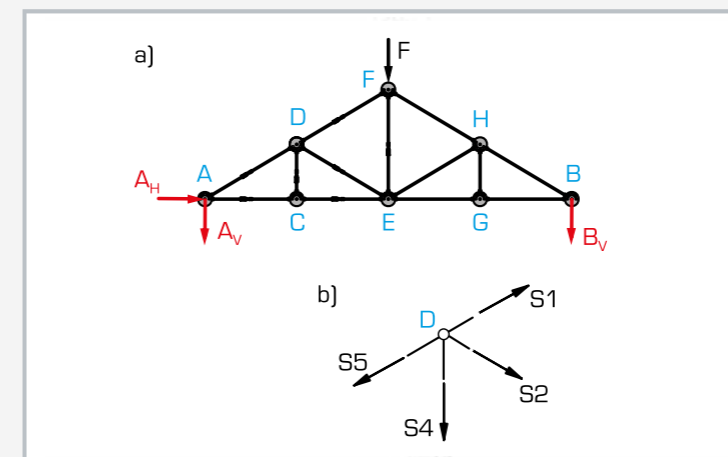

Free-body diagram of a truss, nodal section method:
a) layout, black: applied force, red: support reactions, blue: node;
b) bar forces at node D

Specification

- [1] investigation of bar forces in a single plane, statically determinate truss
- [2] ready assembled Howe truss
- [3] frame for horizontal experimental setup
- [4] influence of dead weight minimized by horizontal experimental setup
- [5] any straight and inclined load cases possible
- [6] fine adjustment of load force
- [7] low-friction knife-edge bearing
- [8] 2 supports for vertical forces, 1 support for horizontal forces
- [9] pre-balanced strain gauge connection box with connection to measuring amplifier FL 152
- [10] measuring amplifier FL 152 required
- [11] GUNT-software in FL 152 to evaluate measured values graphically

Technical data

- Truss: Howe type
- bar cross-section: 10x3mm, stainless steel
 - bar lengths: 115,5, 200, 231mm
 - external loading: max. 500N
 - bars: 13, of which 7 with measuring points

- Load application device with force gauge
- tensile force: max. 600N
 - stroke: 30mm

- Node disks: 8
Angle between bars: 30°, 45°

- LxWxH: 1220x620x250mm (frame)
LxWxH: 850x265x15mm (Howe truss)
Weight: approx. 43kg

Scope of delivery

- 1 frame
- 1 Howe truss
- 1 load application device
- 1 strain gauge connection box
- 1 ribbon cable
- 1 set of instructional material

SE 130.01**Truss beam: Warren girder****Description**

- ready assembled Warren truss
- bars with strain gauge measurement to measure bar force

Warren truss beams are frequently used on steel constructions.

Experiments with the truss SE 130.01 are mounted on the frame of the SE 130 unit. The mechanical construction of the truss ensures that only tensile or compressive forces are active in the bars. The connection between the bars by means of node disks is "hinged". So this can be described as an ideal truss.

The force in the bars is measured using strain gauge measurement. Owing to the symmetrical construction, only half of the bars have measuring points on them. All strain gauge connections are housed together in the strain gauge box.

Learning objectives/experiments

- calculation of tensile and compressive forces in bars in different load cases: straight and inclined forces
- comparison of measuring results with mathematical methods
 - ▶ method of joints
 - ▶ Ritter's method of sections
 - ▶ Cremona diagram

Specification

- [1] investigation of bar forces in a single plane, statically determinate truss
- [2] ready assembled Warren truss beam
- [3] influence of dead-weight minimised by horizontal experiment layout
- [4] any straight and inclined load cases possible
- [5] pre-balanced strain gauge connection box
- [6] SE 130.01 is a supplementary set for the main unit SE 130

Technical data

Truss beam: Warren type

- bar cross-section: 10x3mm, stainless steel
- bar lengths: 270mm, 186,5mm
- tensile force: max. 500N
- bars: 13, of which 7 with measuring points

Node disks: 8

LxWxH: 800x300x15mm

Weight: approx. 8kg

Scope of delivery

- 1 truss beam: Warren type
- 1 strain gauge connection box
- 1 ribbon cable

Data acquisition and visualisation



Optimal evaluation and analysis of conducted experiments

The GUNT software always has comprehensive online help explaining the functions and application.

The GUNT software is developed and maintained in-house by a group of experienced engineers.

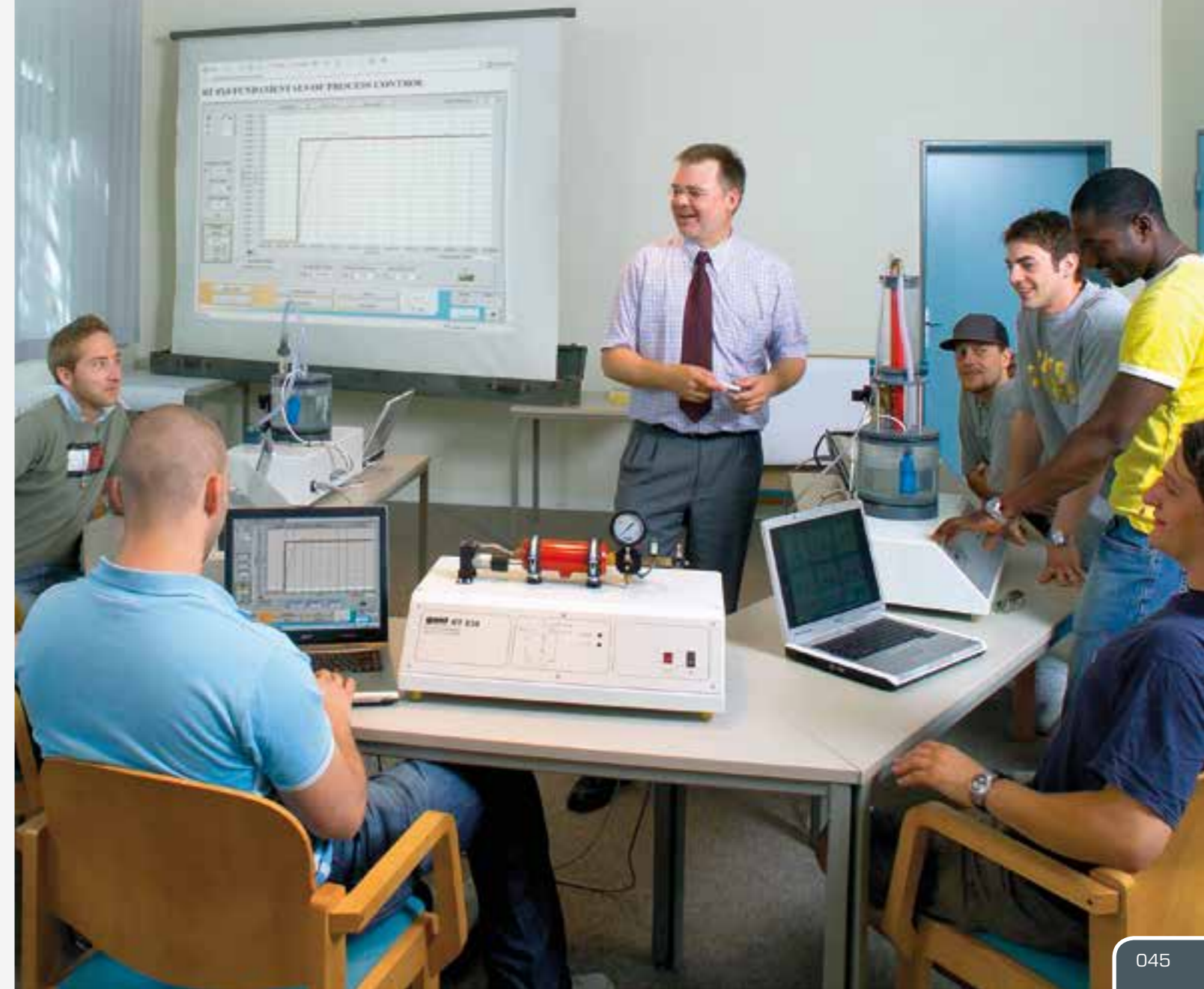

SE 110.18**Forces on a suspension bridge**

The illustration shows SE 110.18 in the frame SE 112.

Description

- stiff or elastic roadway for the suspension bridge
- different load cases possible: point or distributed load
- catenary of a free-hanging cable

Suspension bridges are among the oldest of all bridge designs. Their main supporting element is a flexible cable. Since cables are able to absorb high tensile forces while themselves having little dead-weight, they enable wide-span suspension bridges to be constructed. This makes it possible to bridge longer distances with no supporting pillars, such as over wide gorges. The sag of suspension bridge supporting cables is parabolic in shape, as the weights are attached at relatively short, constant intervals by way of vertical cables to the main supporting cables.

The experimental setup SE 110.18 represents a suspension bridge. The bridge consists of two parallel supporting cables with a roadway suspended between them. U-shaped hangers serve as vertical cables. They are attached to the main supporting cables at regular intervals, and hold the roadway. Deflection rollers act as pylons. The roadway acts upon the supporting cables as a distributed load, and can be loaded by additional weights.

Two roadways with different stiffness are available: one stiff and one elastic roadway. The stiff roadway has a hinge in the middle. The hinge permits internal moments in the roadway occurring in response to uneven loading to be visualised – the roadway buckles.

The experimental setup without roadway deals with free-hanging cables. Cables with different dead-weights are studied by attaching additional point loads directly to the supporting cables.

The tensile forces in the supporting cables are determined with the aid of weights. The maximum sag is measured using a scaled rule. The scaled rule is fixed to a cross-arm.

All the component elements of the experiment are clearly laid-out and housed securely in a storage system. The complete experimental setup is arranged in the frame SE 112.

Learning objectives/experiments

- familiarisation with a suspension bridge
 - ▶ under dead-weight
 - ▶ under additional weight
 - ▶ under evenly distributed load
 - ▶ under unevenly distributed point loads
- calculation of the supporting cable force
- comparison between calculated and measured values of the supporting cable force
- observation of the effect of internal moments in the roadway under uneven load
 - ▶ for a stiff roadway
 - ▶ for an elastic roadway
- determination of the catenary of a free-hanging cable

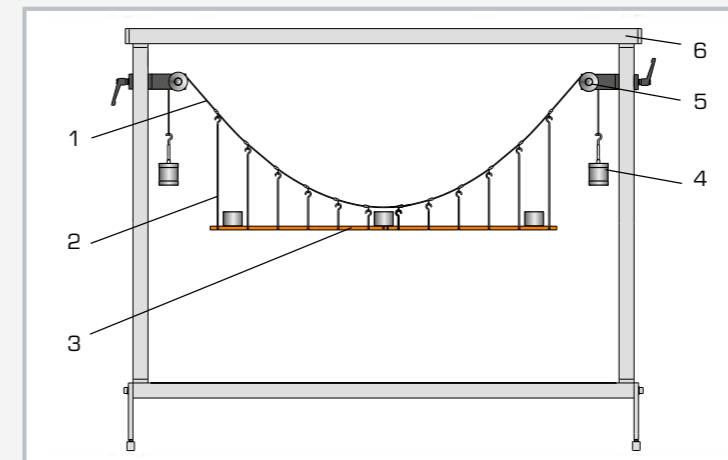

1 supporting cable, 2 hanger, 3 roadway, 4 weight, 5 deflection roller with fixture, 6 frame SE 112

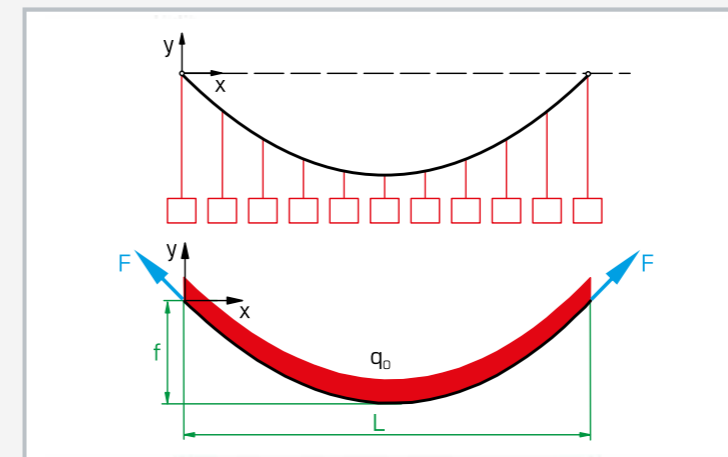
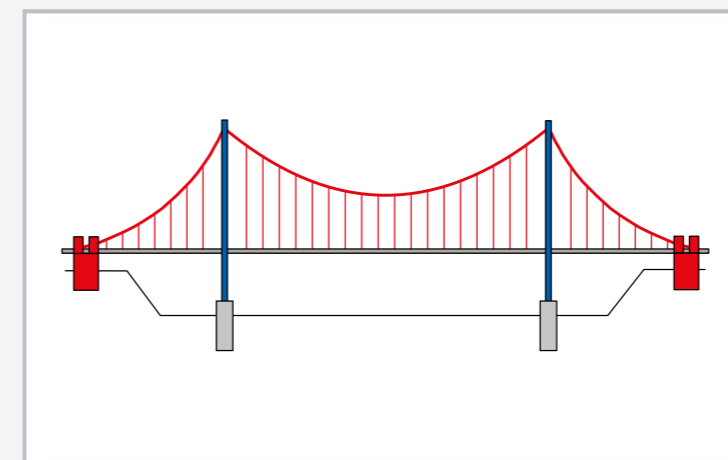
Substitute model for a suspension bridge: "suspended cable with uniformly distributed load" with free-body diagram (bottom); F cable force, q_0 distributed load; f maximum sag, L span

Forces on a suspension bridge: red: tensile forces (acting in the supporting cables, the hangers and the anchorages of the supporting cables), blue: compressive force (acting in the pylons)

Specification

- [1] investigation of a suspension bridge in various load cases
- [2] suspension bridge, consisting of 2 supporting cables, roadway and 2 deflection pulleys as pylons
- [3] supporting cables with parabolic sag
- [4] hangers (vertical supporting cables) in the form of U-shaped shackles in graduated lengths
- [5] roadway (distributed load) can be loaded by additional weights
- [6] 2 selectable roadways: stiff roadway (two-section with central hinge) and elastic roadway
- [7] experimental setup "hanging cable": supporting cables without roadway, loaded with point loads
- [8] 4 hanger to measure the cable force in both supporting cables
- [9] storage system to house the components
- [10] experimental setup in frame SE 112

Technical data**Suspension bridge**

- span: approx. 1050mm
- supporting cable sag: approx. 325mm
- number of supporting cables: 2
- shackles: 12, graduated lengths

Stiff roadway, two-section with hinge, wood

- LxWxH: 1000x70x10mm
- dead-weight of roadway: 5,5N

Elastic roadway, PVC

- LxWxH: 1000x70x3mm
- dead-weight of roadway: 3N

Weights

- 16x 1N (hanger)
- 12x 1N (shackle)
- 24x 1N
- 28x 5N

LxWxH: 1170x480x178mm (storage system)

Weight: approx. 37kg (total)

Scope of delivery

- 2 supporting cables
- 1 set of shackles for roadways
- 1 roadway, stiff
- 1 roadway, elastic
- 2 deflection rollers with fixture
- 1 cross-arm with clamp
- 1 rule
- 1 set of weights
- 1 storage system with foam inlay
- 1 set of instructional material

SE 110.12**Lines of influence on the Gerber beam**

The illustration shows SE 110.12 in the frame SE 112.

Description

- articulated beam with two cantilever beams and a suspended beam as an example of a typical bridge
- direct indication of reactions
- lines of influence for different load cases

Many bridges are executed as Gerber beams. Bridges are subjected to moving loads. Consequently, it is important to take these moving loads into account in the design process. To that end, the so-called lines of influence are determined. Lines of influence describe static reactions to a moving load, such as the internal reactions of the beam or support reactions. The lines of influence are determined by way of method of sections and the conditions of equilibrium, in the same way as the bending moment diagram for a static load for example.

A Gerber beam is an articulated beam, in the case of SE 110.12 with two cantilever beams and a suspended beam between them. Two supports support each cantilever beam. The suspended beam is mounted on articulated supports on each of the cantilever beam arms. As a result the entire beam is statically determinate.

The cantilever beam supports are equipped with force gauges which indicate the support reactions.

Single loads and a moving load are provided to place load on the beam. This means the beam can be subjected to point or distributed loads, or to a moving load. The force gauges indicate the effect of a moving load directly in the support reactions. The supports are movable.

All the component elements of the experiment are clearly laid-out and housed securely in a storage system. The complete experimental setup is arranged in the frame SE 112.

Learning objectives/experiments

- familiarisation with a Gerber beam
- application of the method of sections and the conditions of equilibrium to calculate the support forces for
 - ▶ point load
 - ▶ distributed load
 - ▶ moving load
- determination of the internal reactions under static load
 - ▶ shear force curve
 - ▶ bending moment diagram
- determination of the lines of influence under moving load
- comparison of the calculated and measured reactions for static and moving load

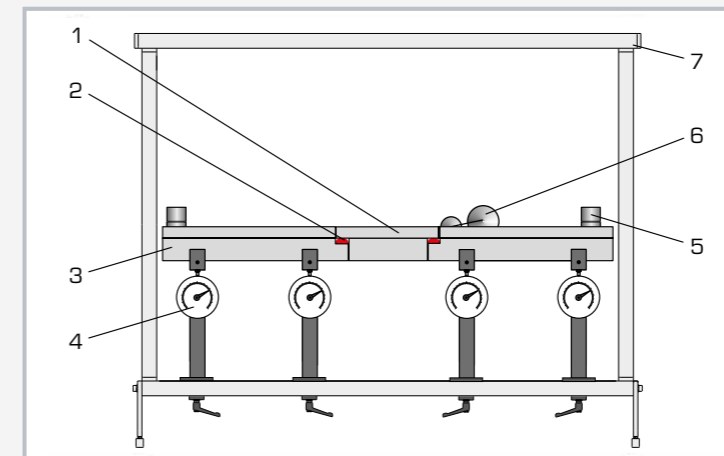

1 suspended beam, 2 articulated support, 3 cantilever beam, 4 support with force gauge, 5 weight, 6 moving load, 7 frame SE 112

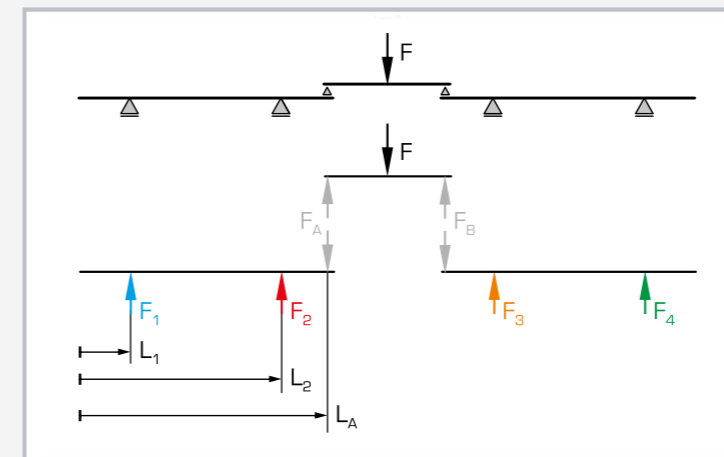
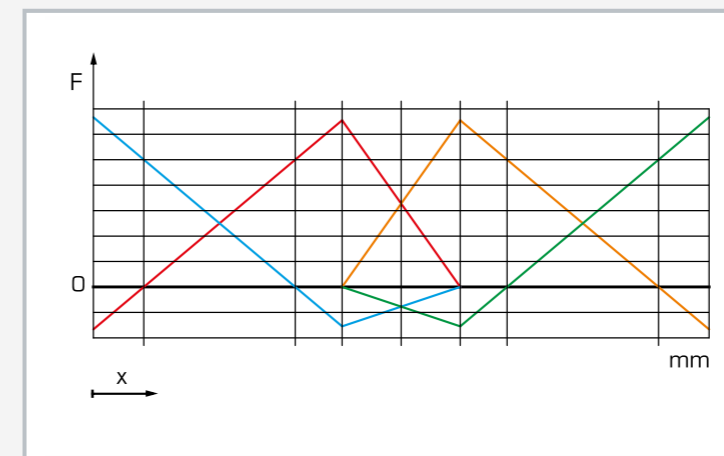
Top: simplified experimental setup (Gerber beam), bottom: free-body diagram: F applied force, $F_A + F_B$ reactions of the articulated supports, $F_1...F_4$ reactions of the supports with force gauge, L_1, L_2, L_A positions of the supports

Lines of influence for a moving point load (see also free body diagram): blue: support 1, red: support 2, orange: support 3, green: support 4

Specification

- [1] investigation of the lines of influence in a statically determinate Gerber beam under different loading
- [2] Gerber beam comprising 2 cantilever beams and 1 suspended beam
- [3] suspended beam mounted by articulated supports on cantilever beams
- [4] beam subjected to moving load or loaded down by single loads
- [5] 4 movable supports with force gauge
- [6] storage system to house the components
- [7] experimental setup in frame SE 112

Technical data**Beam**

- total length: 1220mm
- cantilever beam length: 503mm
- suspended beam length: 250mm

Force gauge: $\pm 50\text{N}$ **Weights**

- 24x 5N
- 12x 1N
- moving load: 10+20N

LxWxH: 1170x480x178mm (storage system)
Weight: approx. 40kg (total)**Scope of delivery**

- 1 Gerber beam (2 cantilever beams + 1 suspended beam)
- 4 supports with force gauge
- 1 moving load
- 1 set of weights
- 1 storage system with foam inlay
- 1 set of instructional material

SE 110.17

Three-hinged arch



The illustration shows SE 110.17 in the frame SE 112.

Description

- statically determinate three-hinged arch
- symmetrical or unsymmetrical arch
- various load cases: point load, distributed load, moving load

Bridges are often constructed as three-hinged arches. This type of construction is particularly suitable when compression-proof building materials are available. Horizontal thrust occurs in the arch at the supports. It permits much lower bending moments in the arch than in the case of a beam on two supports with the same span. A significant longitudinal compressive force is active in the arch to produce this effect.

A three-hinged arch consists of a curved beam mounted on two fixed supports, and usually featuring the so-called crown hinge at its crown. The hinges on the two fixed supports absorb vertical and horizontal forces, and are known as abutment hinges. Their connecting line is the springing line. The crown hinge renders the system statically determinate.

SE 110.17 includes two long arch segments and one short segment, of which two at a time are connected by a hinged joint producing a symmetrical or unsymmetrical three-hinged arch. The arch under investigation can be subjected to point, distributed or moving load. Weights compensate for the support reactions of an abutment hinge, so enabling a comparison between calculated and actual measured values.

All the component elements of the experiment are clearly laid-out and housed securely in a storage system. The complete experimental setup is arranged in the frame SE 112.

Learning objectives/experiments

- familiarisation with three-hinged arches (unsymmetrical and symmetrical)
- application of the method of sections and the conditions of equilibrium to calculate the support forces for
 - ▶ point load, distributed load, moving load
- investigation of the influence of the load on the horizontal thrust in the supports
- determination of the lines of influence for the supports under a moving load
- comparison of the calculated and measured support reactions for static and moving load

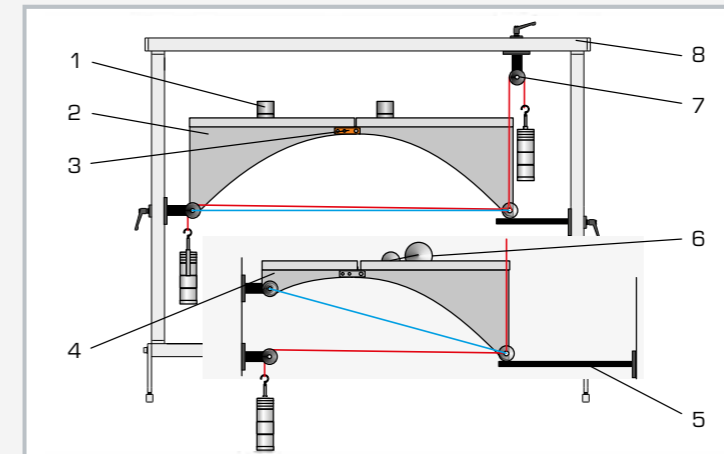

1 weight, 2 long arch segment, 3 crown hinge, 4 short arch segment, 5 support, 6 moving load, 7 deflection roller with fixture, 8 frame SE 112; red: cable, blue: springing line

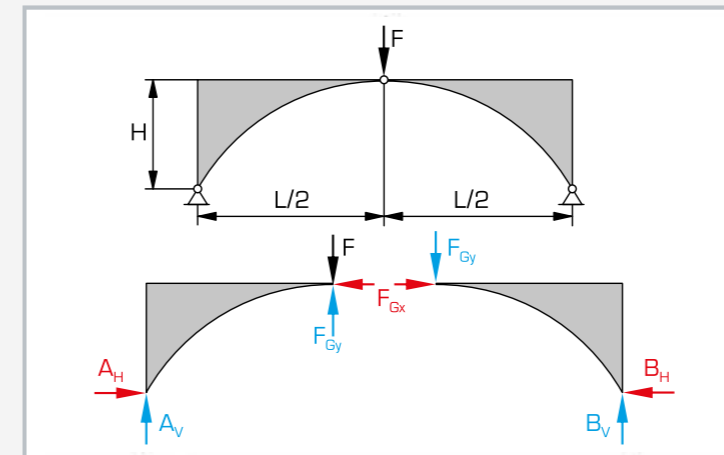

Top: symmetrically loaded three-hinged arch, bottom: free-body diagram of the loaded arch

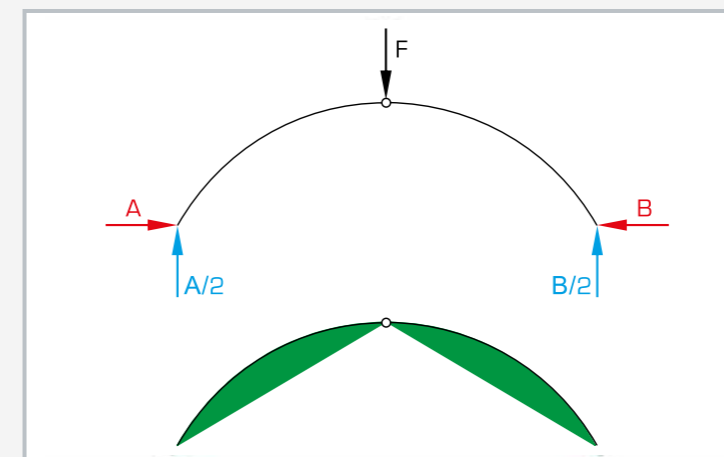

Theoretical bending moment curve in a symmetrically loaded arch: top: free-body diagram with calculated forces, bottom: qualitative bending moment diagram in green

Specification

- [1] investigation of 2 statically determinate three-hinged arches
- [2] hinged arch with 3 hinges: 1 crown hinge, 2 abutment hinges at the support points
- [3] 3 arch segments: 2x long (together making a symmetrical arch), 1x short (together with 1x long: unsymmetrical arch)
- [4] arch subjected to point load, distributed load (each by loads) or moving load
- [5] loads to compensate for the support reactions of an abutment hinge
- [6] storage system to house the components
- [7] experimental setup in frame SE 112

Technical data

Aluminium arches

- 2x long: 480mm, total arch length: 960mm
- 1x short: 230mm, total arch length: 710mm
- arch height: 250mm

Weights

- 4x 1N (hanger)
- 36x 1N
- 16x 5N
- moving load: 10N+20N

LxWxH: 1170x480x178mm (storage system)
Weight: approx. 56kg (total)

Scope of delivery

- 3 arch segments
- 1 moving load
- 2 supports
- 1 set of weights
- 1 set of accessories
- 2x storage system with foam inlay
- 1 set of instructional material

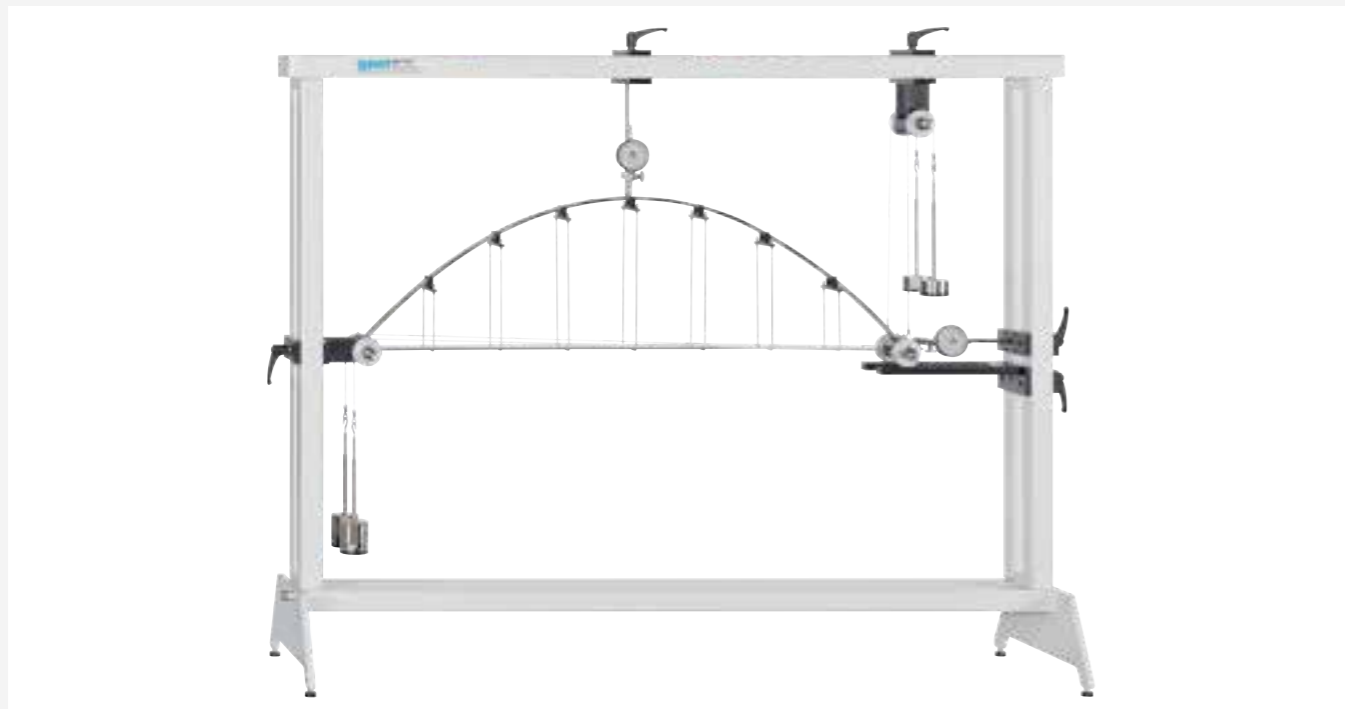
SE 110.16
Parabolic arch

The illustration shows SE 110.16 in the frame SE 112.

Description

- **statically determinate or statically indeterminate parabolic arch under load**
- **deformations of the arch under load**
- **support reactions of the arch**

Parabolic arches are popular elements in construction engineering. They can be employed as bridges or beams for example. Normally these bridges are statically indeterminate. The special feature of the parabolic arch is that in the arch only normal forces and bending moments occur, but no shear forces. That is the case when the arch is subjected to a uniform distributed load and both ends are mounted in fixed supports. This enables arches to be constructed from loosely set stones – a construction technique which has been in existence for many centuries. Loads acting upon the inner of the arch are primarily compressive forces in the direction of the normal force at every point of the arch.

SE 110.16 includes a pre-shaped parabolic arch. It can be subjected to point or distributed loads. It is possible to suspend an elastic roadway and load it.

One of the arch's supports is fixed, the other is horizontally movable support. Weights are used to undo this movement. The movable support thus becomes a fixed support. Additional weights compensate for the vertical support reaction.

Dial gauges record the deflection of the arch under load and the horizontal displacement of the movable support. As long as the movable support is movable, the arch is statically determinate, though it is substantially deformed under load. As soon as the movable support becomes immovable, the arch is no longer statically determinate and is deformed only to a minor degree.

All the component elements of the experiment are clearly laid-out and housed securely in a storage system. The complete experimental setup is arranged in the frame SE 112.

Learning objectives/experiments

- mechanical principles of the parabolic arch
- differences between statically determinate and statically indeterminate arches
- measurement of the deformations of the arch under load
- measurement of the support reactions on the statically indeterminate arch under load
- calculation of the support reactions
- influence of load on reaction forces and deformation of the arch
 - ▶ point load
 - ▶ distributed load
 - ▶ suspended elastic roadway under load

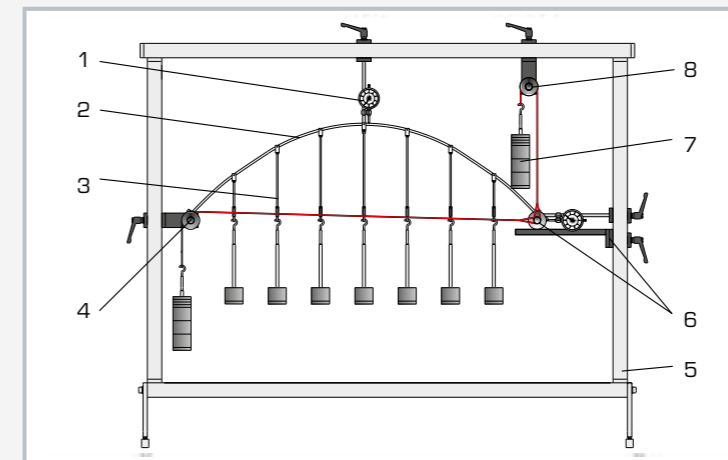

1 dial gauge, 2 arch, 3 shackle, 4 fixed support, 5 frame SE 112, 6 movable support with support plate, 7 weight, 8 deflection roller; red: cable; not shown: elastic roadway

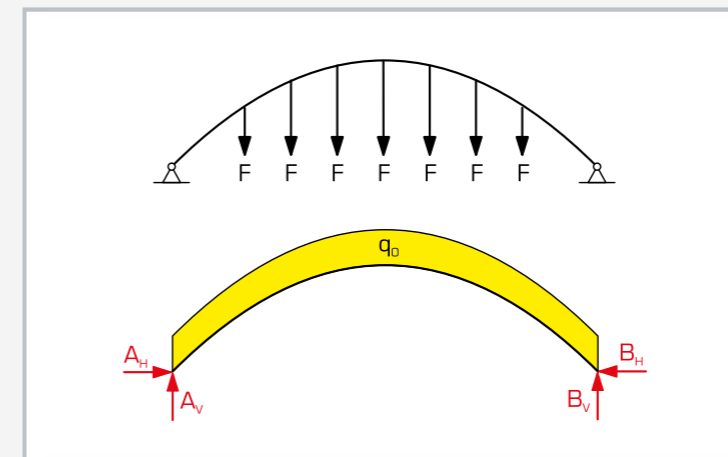
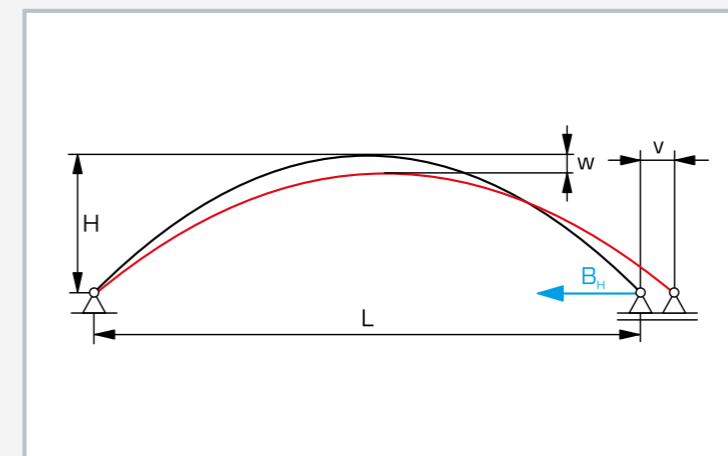
Top: forces on the statically indeterminate parabolic arch, bottom: free-body diagram with distributed load q_0 in yellow (generated from evenly distributed point loads F) and support reactions $F_A + F_B$ in red

Deformation of the statically determinate arch under distributed load: L length, H height, w deflection, v horizontal displacement on the movable support; black arch without load

Specification

- [1] investigation of a parabolic arch, optionally statically determinate (1 fixed support, 1 movable support) or indeterminate (2 fixed supports)
- [2] loading of the arch with a distributed load by way of 7 evenly distributed loads or by point loads or by suspended roadway with loads
- [3] 2 dial gauges record the deformation of the arch under load
- [4] weights to compensate for the reactions of a fixed support
- [5] roadway with 1 set of shackles to be suspended into the arch; shackles in graduated length
- [6] storage system to house the components
- [7] experimental setup in frame SE 112

Technical data

Parabolically pre-shaped steel arch

- length: 1000mm
- height: 280mm
- cross-section: 20x6mm

Roadway made of PVC

- dead-weight: approx. 2,6N
- LxWxH: 900x70x3mm

Dial gauge

- measuring range: 0...25mm
- graduation: 0,01mm

Weights

- 11x 1N (7+4 hanger)
- 7x 1N (shackle)
- 36x 1N
- 19x 5N

LxWxH: 1170x480x178mm (storage system)

Weight: approx. 38kg (total)

Scope of delivery

- 1 arch with 7 shackles + 7 hangers
- 1 roadway with shackles
- 1 set of weights
- 2 deflection rollers with fixture
- 1 support
- 2 dial gauges
- 1 storage system with foam inlay
- 1 set of instructional material

FL 152 PC-based recording and analysis of strain gauge signals

SE 110.21

Forces in various single plane trusses

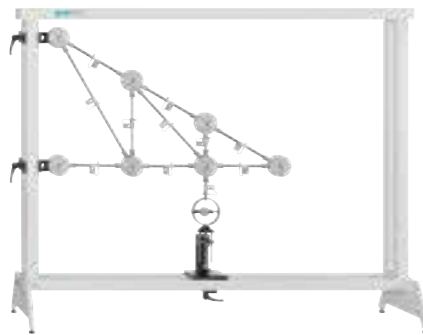

Page 38

FL 120

Stress and strain analysis on a membrane



Page 130

SE 110.22

Forces in an overdeterminate truss

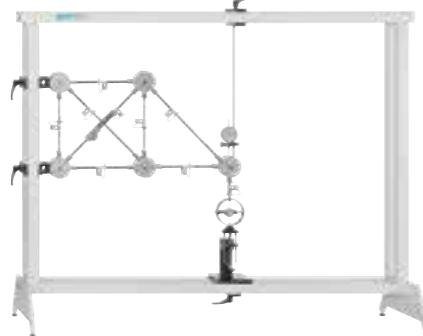

Page 40

FL 130

Stress and strain analysis on a thin-walled cylinder



Page 132

SE 130

Forces in a Howe truss



Page 42

FL 140

Stress and strain analysis on a thick-walled cylinder



Page 134

Whenever our experimental units are used to record forces or stresses using a strain gauge, the FL 152 unit amplifies the measuring signals. These signals are processed further and analysed using the GUNT software.

The unit has 16 input channels for processing analogue strain-gauge measuring signals.

FL 152 is used as either a stand-alone unit or connected to a PC via a USB interface.

The GUNT software supports the topics of stress analysis and truss analysis in a format prepared for teaching.

- touchscreen operation
- the measured values are displayed on the unit or on a PC

GUNT software in FL 152 for conducting and analysing experiments on stress analysis

- read measured values and save to a file
- plot stress and strain curves
- calculate principal strains and principal stresses
- experiment analysis using Mohr's strain circle
- Windows system requirements

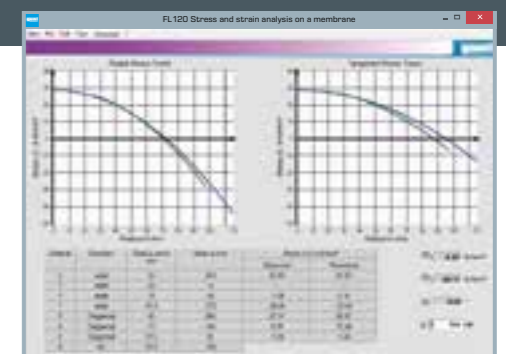

GUNT software in FL 152 for conducting and analysing experiments on truss analysis

- support for conducting and analysing experiments
- simulation of trusses
- configurable trusses
- comparison of occurring forces: theory and measurement
- possible to print out worksheets



FL 152

Multi-channel measuring amplifier



Description

- 16 input channels for processing of analogue strain gauge measuring signals, easy connection by multi-pin input port
- integrated software for evaluation of stress and strain analysis experiments (FL 120, FL 130, FL 140) and experiments relating to forces in trusses (SE 130, SE 110.21, SE 110.22)

Stresses and strains occurring in components are determined in experimental stress and strain analysis by measuring strain. In industry, strain is often recorded by strain gauges. Since strain gauges deliver only small analogue measuring signals, the signals must be amplified in measuring amplifiers. Then they are converted into digital pulses and displayed as measured strain. These strains may also be evaluated and processed on computer.

FL 152 is a multi-channel measuring amplifier which supplies the strain gauge bridge circuits with power and processes the received measuring signals. The measuring amplifier includes 16 input channels. The strain gauge measuring points are connected to associated balance potentiometers by a 68-pin multiport.

The multi-channel measuring amplifier is operated via touchscreen or via PC using the supplied software. The measured values can be read and saved on computer (using an application such as MS Excel).

Learning objectives/experiments

- amplification and display of signals from strain gauge measuring points
- processing of measured values on computer
- evaluation of stress and strain analysis experiments, in conjunction with: FL 120, FL 130, FL 140
- evaluation of experiments relating to forces in trusses, in conjunction with: SE 130, SE 110.21, SE 110.22

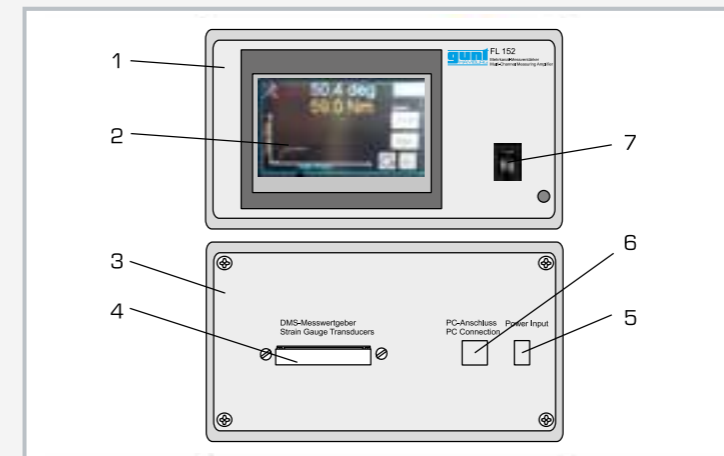

1 front view, 2 touchscreen, 3 rear view, 4 connection of strain gauge measuring points, 5 electric supply, 6 USB interface, 7 main switch



Application software for stress and strain analysis based on the example of the FL 120 (stress and strain analysis on a membrane)



Example application: FL 152 in conjunction with FL 140 (stress and strain analysis on a thick-walled cylinder)

Specification

- [1] multi-channel measuring amplifier for processing of strain gauge signals
- [2] strain gauge connection in half or full bridge configuration
- [3] strain gauge connection via 68-pin input port
- [4] automatic tare of measured values
- [5] processing of measured values directly in the measuring amplifier or using the supplied software on a PC
- [6] integrated software for experimental units on stress and strain analysis [FL 120, FL 130, FL 140] and on forces in trusses [SE 130, SE 110.21, SE 110.22]
- [7] GUNT software for data acquisition via USB under Windows 7, 8.1, 10

Technical data

Amplifier

- number of input channels: 16

Strain gauge connection in half or full bridge configuration

- resistance: min. 350 Ohm/strain gauge
- strain gauge supply voltage: $\pm 5\text{VDC}$

Input voltage: max. $\pm 32\text{mV}$

230V, 50Hz, 1 phase
230V, 60Hz, 1 phase; 120V, 60Hz, 1 phase
UL/CSA optional
LxWxH: 230x200x120mm
Weight: approx. 2kg

Required for operation

PC with Windows recommended

Scope of delivery

- 1 multi-channel measuring amplifier
- 1 GUNT software CD + USB cable
- 1 manual

SE 112

Mounting frame



Specification

- [1] frame for mounting of experiments in statics, strength of materials and dynamics
- [2] sturdy sectional steel double frame, welded
- [3] easy, exact mounting of all components by precision clamp fixings
- [4] stable on laboratory desktops or workbenches
- [5] frame supplied disassembled

Technical data

Mounting frame made of steel sections

- frame opening WxH: 1250x900mm
- section groove width: 40mm

LxWxH: 1400x400x1130mm (assembled)
LxWxH: 1400x400x200mm (without mountings)
Weight: approx. 32kg

Scope of delivery

- 1 mounting frame, disassembled
- 1 set of bolts with hexagon socket wrench
- 1 instruction manual

Description

■ mounting frame for setup of experiments in statics, strength of materials and dynamics

The mounting frame SE 112 provides a clearly laid-out, user-friendly means of setting up experiments in the fields of statics, strength of materials and dynamics.

SE 112 comprises four steel sections which are bolted together to form a frame. Two feet on the sides provide stability. The frame is quick and easy to assemble, with just a few actions needed.

GUNT storage systems keep your lab tidy!

TM 115

Forces in a crane jib



WP 960

Beam on two supports:
shear force & bending moment diagrams

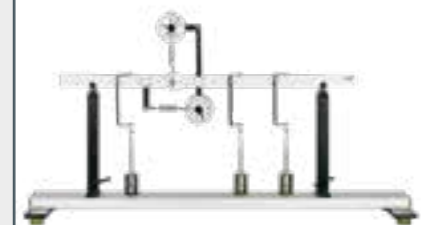

SE 110.21

Forces in various
single plane trusses

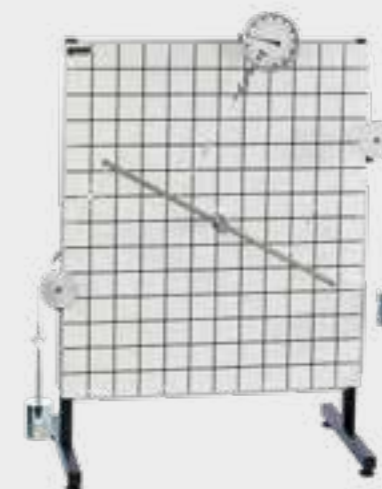
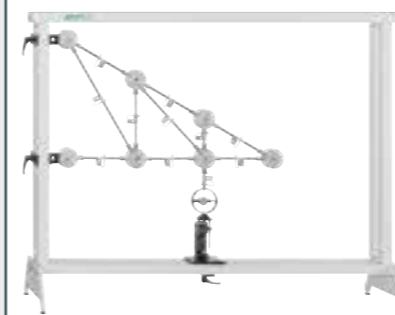

TM 110

Fundamentals of statics



TM 110.02

Supplementary set –
pulley blocks



TM 110.03

Supplementary set –
gear wheels

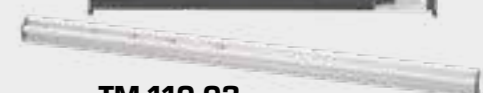

Course engineering mechanics

GUNT-Structure Line

A course on engineering
mechanics

Course engineering mechanics

In GUNT, the term "structure" refers to a supporting structure or a building structure. The term "line" refers to a GUNT series of units. The GUNT-Structure Line is a series of units that has been specially developed by GUNT to support teaching basic engineering principles with practical exercises.

The GUNT-Structure Line offers the following advantages:

- meaningful compilation of experiment subjects
- wide range of experiments: one frame is combined with different add-on parts
- easy to transport and space-saving storage of the add-on parts thanks to stackable storage systems
- orderliness when conducting experiments, thanks to individual parts being stored in clear foam inserts
- safe storage of small parts such as screws, adapters, or tools in transparent boxes
- stable mounting frame, easy to assemble and disassemble, with rubber feet for secure standing
- easy-to-install add-on parts can be fitted at any point on the frame using adjustable clamping levers

The series of units offers a variety of opportunities to learn about common topics such as equilibrium conditions, forces and deformations or stability and buckling and to develop a more in-depth understanding.

A mounting frame for diverse experiment configurations



- easy mounting
- secure standing
- sturdy and versatile frame
- form-fitting clamping connection for the add-on parts

Experiments on statics

SE 110.16
Parabolic arch

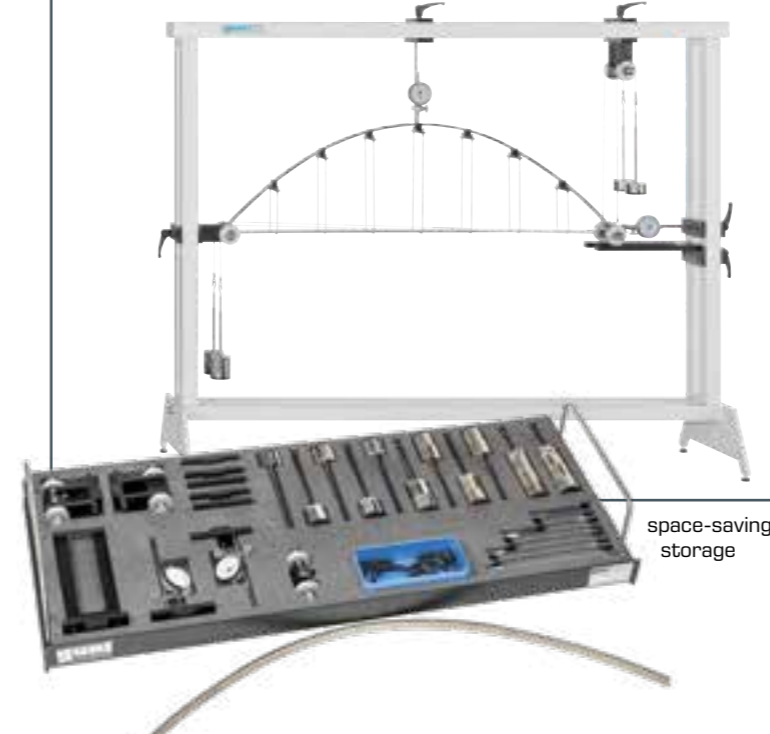

SE 110.50
Cable under
dead-weight

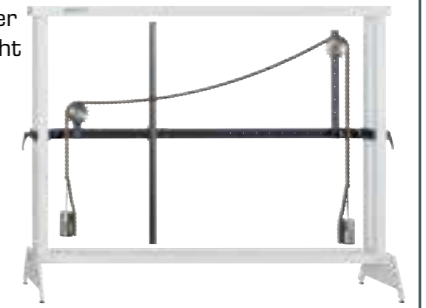

SE 110.21
Forces in
various
single
plane
trusses

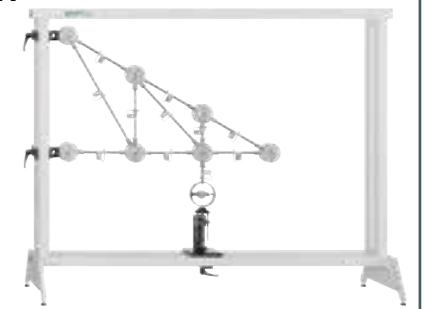

Experiments on strength of materials

SE 110.44
Deformation
of trusses



SE 110.47
Methods to
determine
the elastic
line



SE 110.19
Investigation of simple stability problems



space-saving
storage



Didactic concept of the GUNT-Structure Line

The GUNT-Structure Line allows you to build an extensive laboratory on the fundamentals of engineering. In this way, the rather abstract contents of the lecture can be practically simulated and clearly represented through small-group experiments. This promotes students' long-term learning success. Meanwhile, group participants' social skills are encouraged in addition to their more technical skills.

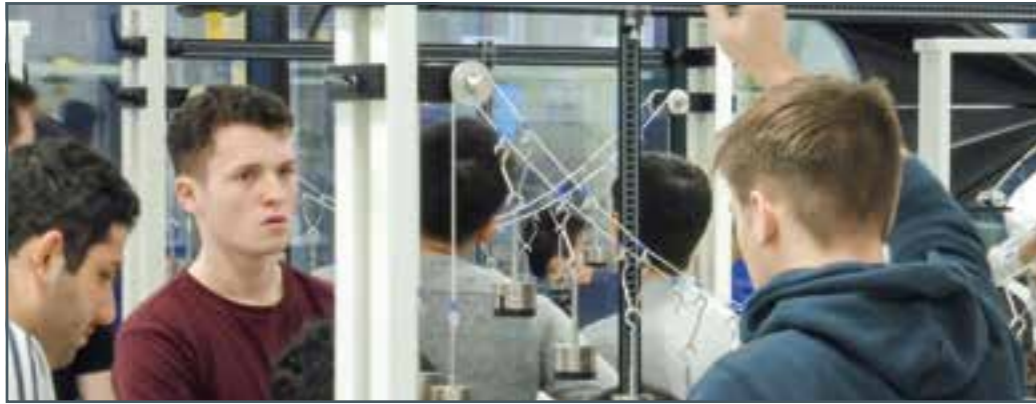

Manual experimentation promotes the following capabilities:

- planning experimental series
- setup of experiments
- encouraging abstraction skills
- encouraging manual work and technical ability
- encouraging effective teamwork

How does manual experimentation promote skills?

- The abstract structural diagram must be implemented in a real experimental setup. This requires imagination, judgement and manual dexterity. Students learn how to technically realise abstract concepts such as clamping or flexible supports. The limits of idealisation are also made clear.
- Terms such as stability and balance of a system are illustrated by the manual application of the load.
- The load on the experimental setups, mainly from weights, gives students a feeling for masses and forces.
- Measuring the deformation using dial gauges provides direct feedback of the load. The factors of slack, friction and the resulting hysteresis – which are almost always present in real systems – can be experienced.

- implementing theoretical teaching subjects in the experiment
- developing an understanding of forces and stresses

- evaluating results
- estimating errors

Mechanical experimental setup

Frame, components and connecting elements are combined into a functioning experimental setup. The points of action for loads, their effect on the support structures and structural elements and the use of fixed and movable supports are tested.

This makes the function and the processes in support systems easy to observe and understand and it ensures a lasting learning experience.



Didactic material in paper form



A fundamental section with the relevant theory and model-based experiment instructions allow an intensive preparation for the experiment. Sample experiment results allow a qualified assessment of the students' own results.

Our didactic materials offer excellent support when preparing lessons, when conducting the experiments and when reviewing the experiment.

Unit-specific, supplementary GUNT software

The software forms a bridge between the mechanical model and the didactic material in paper form.

Trusses can be simulated and configured in the software. Similarly, the behaviour of truss systems is reflected in concrete measured values and the bar forces are graphically displayed (SE 110.21, SE 110.22).

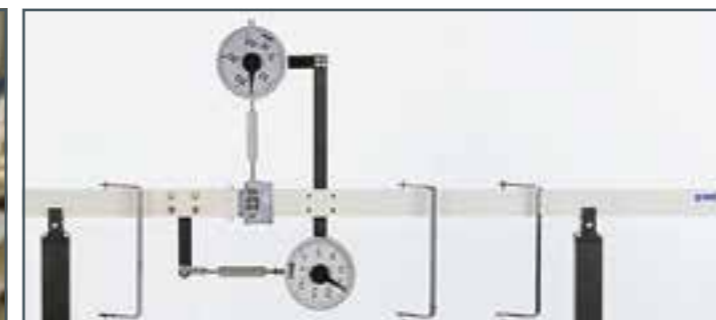
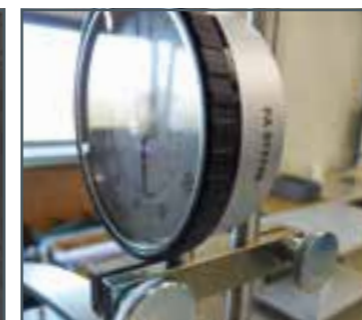
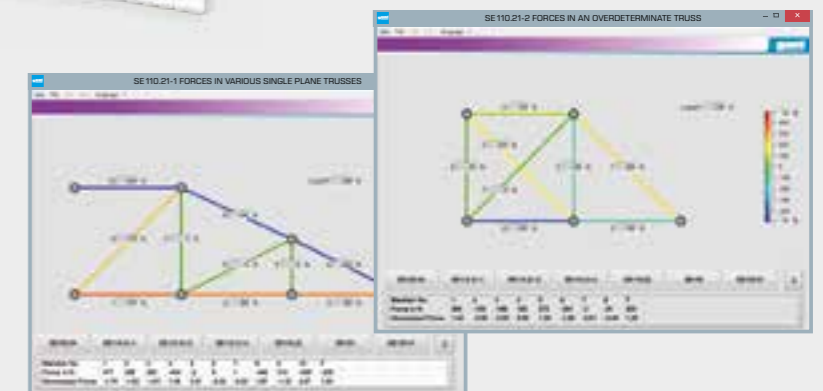

Contents of the GUNT-Structure Line

A wide range of experiments with a variety of options

The series of units covers topics such as equilibrium conditions, forces and deformations or stability and buckling.

The units represent self-contained learning units, complementing the experimental units from a topic in terms of the learning objectives.

For a complete experimental setup, the components of an experimental unit are assembled in the SE 112 mounting frame.



Equilibrium conditions

SE 110.50 Cable under dead-weight

- determine catenary of a free-hanging cable
- measure sag
- compare calculated and measured values

SE 110.53 Equilibrium in a single plane, statically determinate system

- the main principle of the practical experimentation: free-body diagrams in statics
- calculation of support forces
- application of the 1st and 2nd equilibrium conditions of statics

Bridges, beams and arches

SE 110.12 Lines of influence on the Gerber beam

- application of the method of sections and the equilibrium conditions of statics to calculate the support forces
- determine the internal reactions under static load

SE 110.16 Parabolic arch

- mechanical fundamentals of the parabolic arch
- differences between statically determinate and statically indeterminate arches
- influence of load on the support forces and deformation of the arch

SE 110.17 Three-hinged arch

- investigation of how the load affects the horizontal thrust in the supports
- determine the influence lines for the supports under a moving load

SE 110.18 Forces on a suspension bridge

- calculate supporting cable force
- observe the effect of internal moments in the carriageway under uneven load

Forces and deformations in a truss

SE 110.21 Forces in various single plane trusses

- dependence of bar forces on external forces
- comparison of measuring results with mathematical solutions using: the method of joints and Ritter's method of sections

SE 110.22 Forces in an overdeterminate truss

- distribution of forces in a plane truss, depending on the use of a redundant bar
- dependence of bar forces on an external force

SE 110.44 Deformation of trusses

- work-energy theorem and deformation energy
- application of Castigliano's first theorem for calculating deformation at a defined point
- comparison of the deformations of different trusses under the same load

Elastic and permanent deformations

SE 110.14 Elastic line of a beam

- elastic line under different loads / support conditions
- demonstration of Maxwell-Betti's theorem

SE 110.47 Methods to determine the elastic line

- principle of virtual work (calculation), Mohr's analogy (Mohr's method on an area of moments; graphical approach)
- applying the superposition principle of engineering

SE 110.20 Deformation of frames

- interaction between stress and strain on the frame
- first-order law of elasticity for statically determinate and indeterminate systems

SE 110.29 Torsion of bars

- shear modulus and polar second moment of area
- angle of twist as a function of the clamping length / twisting moment
- influence of torsional stiffness on twist

SE 110.48 Bending test plastic deformation

- load of a bending beam with a point load
- create a force-path diagram

Stability and buckling

SE 110.19 Investigation of simple stability problems

- determine the buckling force
- investigate buckling behaviour under the influence of additional shear forces or pre-deformation

SE 110.57 Buckling of bars

- investigate buckling behaviour under the influence of different supports, clamps, cross-sections, materials, or additional transverse stress
- test Euler's theory: buckling on elastic bars
- calculate the expected buckling force with Euler's formula
- graphical analysis of the deflection and the force

Vibrations in a bending beam

SE 110.58 Free vibrations in a bending beam

- free vibration in a vertical and horizontal bending beam
- determine the natural Rayleigh frequency
- how do clamping length and mass affect the natural frequency

Basic knowledge Static and kinetic friction

While in statics, we study idealised bodies excluding frictional forces, in the study of static and kinetic friction, we investigate real solid bodies. Friction occurs in all solid bodies that are in contact and that are moved against each other. The cause of the occurring forces is, among other things, the surface roughness, which causes the surfaces to interlock.

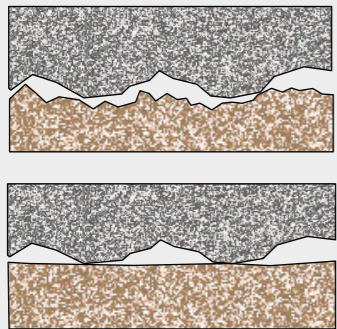

Top two solid bodies, both with high surface roughness; bottom one solid body with high surface roughness and one body with low surface roughness

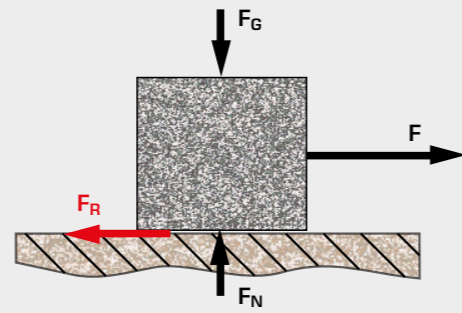

F_G weight, F_R frictional force, F_N normal force, F external force, for example tensile force

Coulomb's law of friction states that the frictional force is proportional to the normal force.

The proportionality factor μ depends on the materials pairing of the bodies and is called the coefficient of friction.

$$F_R = \mu \cdot F_N$$

Typical values for the coefficient of friction μ

Materials pairing	Coefficient of friction μ
steel on steel	0,1 bis 0,4
steel on teflon	0,04
aluminium on aluminium	1,1 bis 1,7
wood on wood	0,3

Types of friction

We differentiate between two types of friction: **static friction**, where there is no movement of the bodies relative to each other and **dynamic friction**, where the surfaces move relative to each

other. The roughness of the surfaces is described by the coefficient of friction μ_S , for static and μ_K , for dynamic friction.

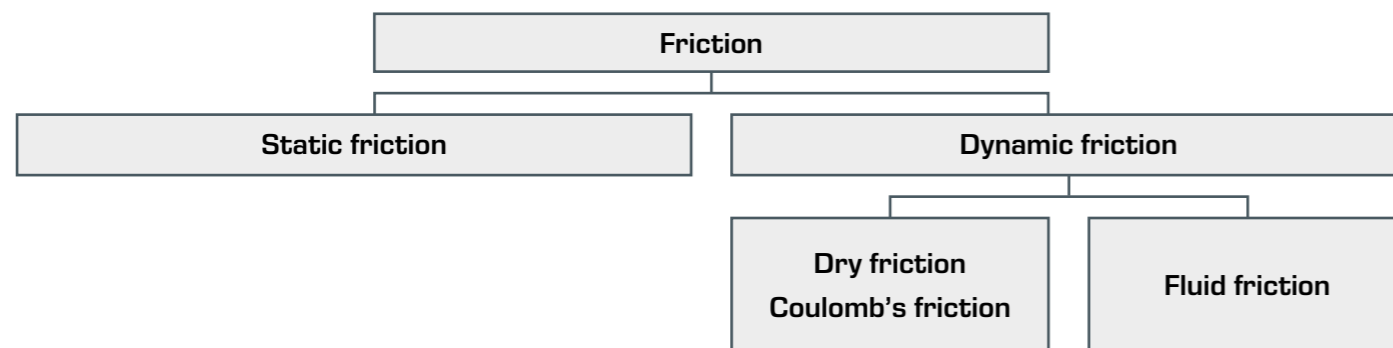

Static friction

Static friction is present if displacing forces are acting on both bodies, but the bodies have not started to move relative to each other yet. This is why we also talk about static friction that has to be overcome if we want to move a body. Static friction is a reaction force; in statically determinate systems, it can be determined from the equilibrium conditions.

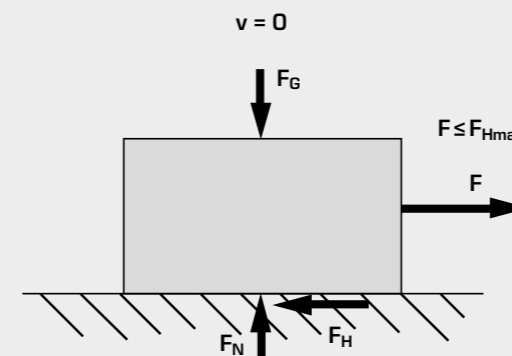

The body adheres to its under-layer

F_G weight, F_H force of static friction, F_N normal force, F external force, v velocity

$$F \leq F_{Hmax}$$

$$F_{Hmax} = \mu_S \cdot F_N$$

F_{Hmax} maximum force of static friction, μ_S coefficient of static friction, F_N normal force, F external force

Dynamic friction

Dynamic friction occurs when a body moves along another and in contact with it, i.e. it actually rubs against it. Dynamic friction increases with the roughnesses of the bodies' surfaces and the pressure applied between the bodies. The dynamic friction force is a physical force (active force) and proportional to the normal force F_N .

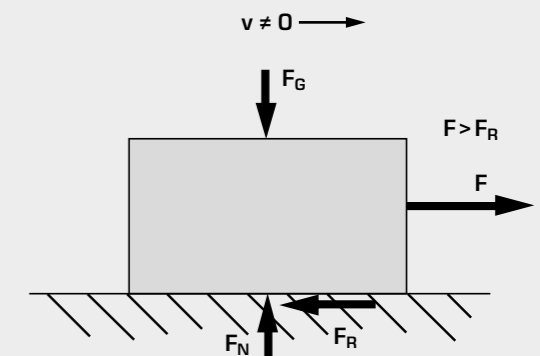

The body slides over its underlayer

F_G weight, F_R force of dynamic friction, F_N normal force, F external force, v velocity

$$F > F_R$$

$$F_R = \mu_K \cdot F_N$$

F_R force of dynamic friction, μ_K coefficient of dynamic friction, F_N normal force, F external force

The proportionality constant is called the coefficient of static friction μ_S . It depends on the material and the surface characteristics of the respective body. Whenever the applied force exceeds the maximum static friction, a body begins to slide.

When calculating friction: the coefficient of dynamic friction μ_K is generally smaller than the coefficient of static friction μ_S .



TM 210

Dry friction

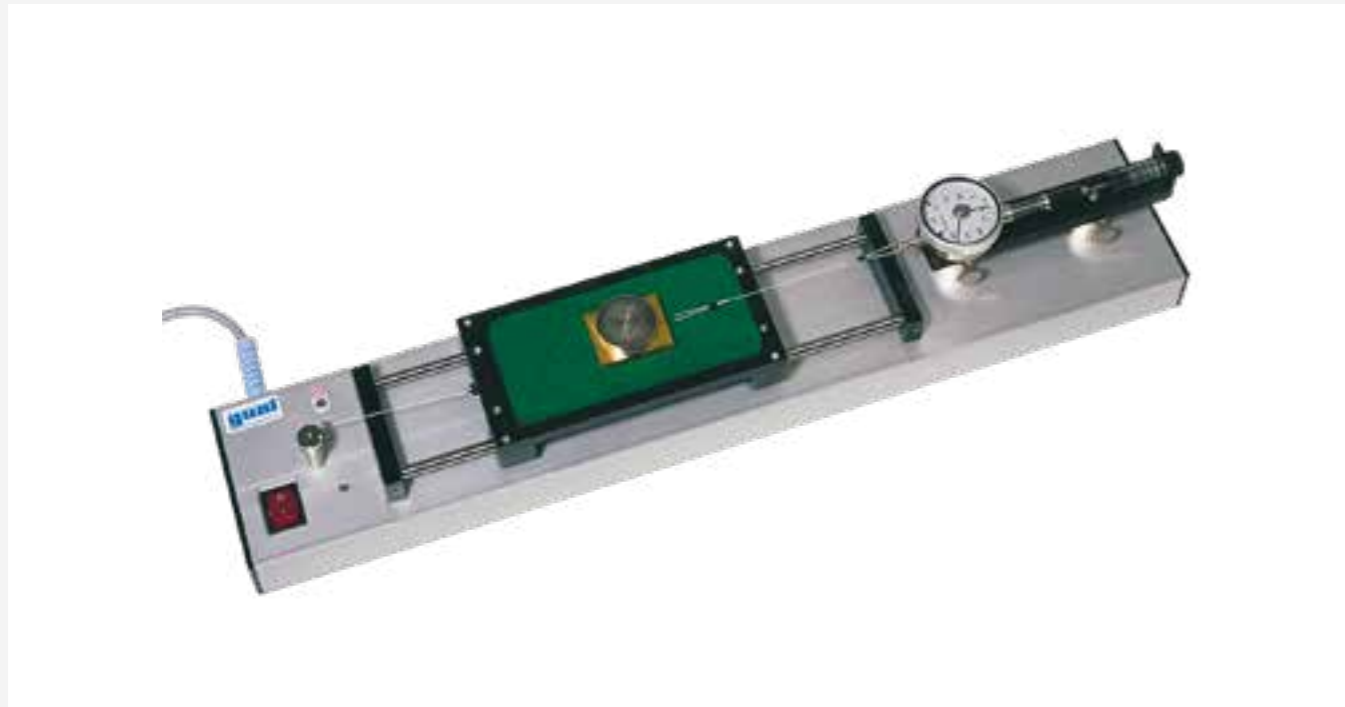

The illustration shows a similar unit.

Description

- fundamentals of mechanical friction
- stationary friction body, uniformly moving support friction surface
- force gauge with air damping cylinder

Friction is a key factor in mechanical engineering. Static friction needs to be adequate to fix components to each other, such as parking brakes, self-locking threads and frictionally engaged connections. Dynamic friction needs to be kept as low as possible, such as on bearings, in guideways or in shaping tools. Consequently, great attention is paid to the topic in engineering mechanics, and understanding of it is enhanced by clearly laid-out experiments.

TM 210 provides a broad range of experiments relating to static and dynamic friction between solid bodies which are in contact with each other and moving relative to each other. Various influences on friction can be investigated, such as surface properties and material pairing.

A support friction surface slides beneath the stationary friction body. The support friction surface is held in a carriage which is drawn along by a motor at uniform velocity by a motor.

The friction body is connected to a height-adjustable force measuring unit. This ensures that the lines of action of friction force and tensile force are parallel. The force measuring unit is essentially a force gauge which is fitted with an air damper to compensate as far as possible for slip/stick effects and so indicate a mean friction force (with no spiking).

Three support surfaces and two friction bodies are available. The normal force can be varied by adding weights.

Experiments can be performed at two constant velocities. The air damping is adjustable. When it is inactive, slip/stick effects can also be observed.

All parts are clearly laid out and well protected on a storage system.

Learning objectives/experiments

- difference between static and dynamic friction
- friction forces as a function of
 - ▶ normal force
 - ▶ sliding velocity (relative velocities of the friction partners)
 - ▶ material pairing
 - ▶ surface properties of the friction partners
 - ▶ size of the contact area
- slip/stick effect
- determination of friction coefficients

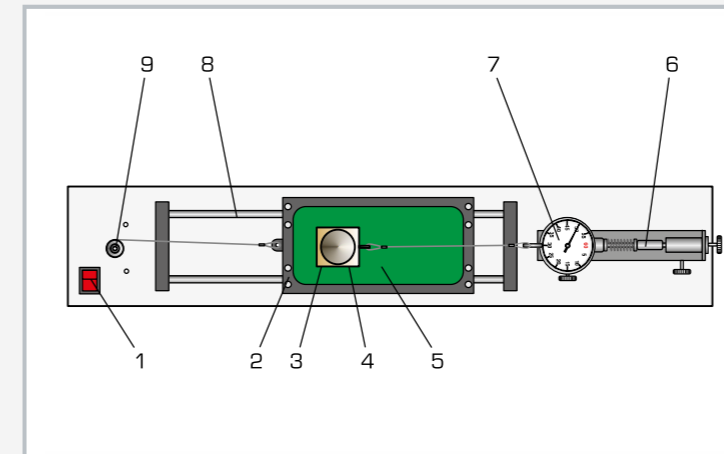

1 mains power switch, 2 carriage, 3 friction body, 4 additional weight, 5 supporting friction surface, 6 damping cylinder, 7 force gauge, 8 guide, 9 drive motor with cable drum

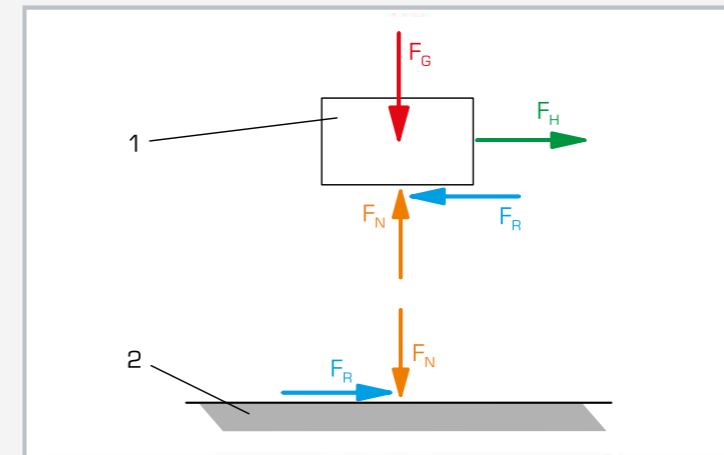

Forces occurring in dynamic friction: 1 friction body, 2 supporting friction surface; F_G : weight, F_H : tensile force, F_R : friction force, F_N : normal force

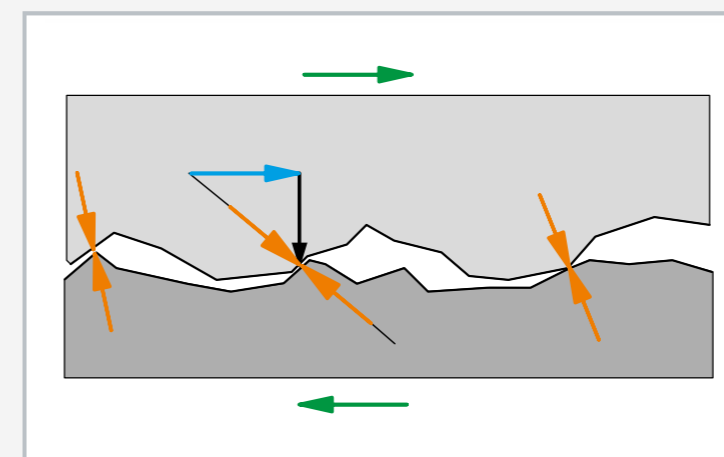

Rough surface between 2 bodies sliding alongside each other
orange: normal force perpendicular to the contact surfaces of both bodies, blue: n-th portion of the friction force, green: relative direction of motion between the bodies, black: resultant force from normal force and friction force

Specification

- [1] mechanical friction between 2 solid bodies
- [2] friction body stationary, support friction surface in a moving carriage
- [3] 2 friction bodies each with 2 different surfaces
- [4] 3 support friction surfaces with a total of 4 different surfaces
- [5] carriage driven by cable pulley and motor
- [6] 2 driving velocities via a graduated cable drum
- [7] force measuring unit: force gauge and adjustable air damper
- [8] force measuring unit height-adjustable
- [9] lines of action of friction force and tensile force always parallel
- [10] adjustable air damper – with damping: measurement of a mean friction force adjusted by disturbances, without damping: slip/stick effects measurable
- [11] storage system to house all parts

Technical data

Support friction surface

- LxWxH: approx. 175x80x6mm
- aluminium
- PVC / felt
- glass

Friction body

- LxW: approx. 50x40mm
- dead-weight force: approx. 1N
- smooth / rough (Al), h=20mm
- brass / felt, h=5mm

Drive

- synchronous motor
- speed: 100min⁻¹
- driving velocities: 23,5cm/min, 47cm/min

Force gauge with damper

- measuring range: 0...2N, graduation: 0,05N

Weights: 8x 0,5N

230V, 50Hz, 1 phase
230V, 60Hz, 1 phase; 120V, 60Hz, 1 phase
UL/CSA optional
LxWxH: 720x480x178mm (storage system)
Weight: approx. 10kg (storage system)
Weight: approx. 7kg (experimental unit)

Scope of delivery

- 1 experimental unit
- 1 set of weights
- 2 friction bodies
- 3 support surfaces
- 1 storage system with foam inlay
- 1 set of instructional material

TM 200

Fundamentals of mechanical friction



Learning objectives/experiments

- difference between static and dynamic friction
- friction forces as a function of
 - ▶ normal force, material pairing, size of contact area
 - ▶ sliding velocity (relative velocities of the paired materials)
 - ▶ surface properties of the paired materials
- determine coefficients of friction

Specification

- [1] fundamentals of mechanical friction
- [2] stationary friction body and force gauge and motor-driven support friction surface
- [3] 2 friction bodies, each with two different surfaces
- [4] 2 supporting friction surfaces with a total of three different surfaces
- [5] 2 cable drum driving velocities
- [6] force gauge overload-proof with clearly legible dial
- [7] storage system for all parts

Technical data

- Supporting surfaces
- Al / felt, PVC
- Friction body
- smooth / rough (Al), brass / felt
- Drive with synchronous motor
- driving velocities: 23,5cm/min; 47cm/min
- Force gauge
- measuring range: 0...2N
 - graduation: 0,1N
- Weights
- 8x 0,5N

- 230V, 50Hz, 1 phase
230V, 60Hz, 1 phase
120V, 60Hz, 1 phase; UL/CSA optional
LxWxH: 720x480x178mm (storage system)
Weight: approx. 10kg (storage system)
Weight: approx. 4kg (experimental unit)

Scope of delivery

- 1 experimental unit
- 1 set of weights
- 2 friction bodies
- 2 supporting friction surfaces
- 1 storage system with foam inlay
- 1 set of instructional material

Description

■ fixed friction body and uniformly moving friction surfaces

The unit provides fundamental experiments on static and dynamic friction. Two solid bodies are moved against each other in a uniform manner. The frictional forces occurring in the process are measured. The friction body under investigation is connected to a force gauge and remains at rest.

The paired material is driven by a motor and slides beneath the friction body. Two sliding velocities can be selected. The normal force is altered by adding extra weight to the bodies.

All parts are clearly laid out and well protected in a storage system.

TM 225

Friction on the inclined plane



Learning objectives/experiments

- determination of the friction coefficients of various material pairings
- transition from static to dynamic
- static equilibrium of forces on the inclined plane
- determination of the angle of inclination as from which sliding occurs [calculation and verification by experiment]

Specification

- [1] experiment relating to friction on the inclined plane
- [2] inclined plane with plastic coating, drag link with angle scale and ball bearing-mounted deflection roller
- [3] angle of plane adjustable
- [4] 2 samples
- [5] graduated weight set

Technical data

- Friction body
- LxWxH: each 80x60x44mm
 - dead-weight force: each 10N
 - 1x steel / polypropylene
 - 1x aluminium / brass

- Inclined plane
- length: 1000mm
 - adjustable angle range: $\pm 45^\circ$

- Weights
- 1x 1N (hanger), 4x 0,1N, 1x 0,5N, 4x 1N, 1x 5N

- LxWxH: 1130x300x800mm
Weight: approx. 35kg

Scope of delivery

- 1 experimental unit
- 1 set of weights
- 2 samples
- 1 set of instructional material

Description

■ dry friction on the inclined plane ■ fundamentals of mechanical friction

Friction experiments on the inclined plane help students to understand the fundamentals of mechanical friction.

The main elements of TM 225 are a sliding surface (the inclined plane), with an adjustable angle of inclination, and different samples. A sample is moved from the stationary state to the sliding state in two ways.

In the first experiment, the plane is carefully tilted until the sample begins to slide downwards and the downward force is greater than the static friction force.

In the second experiment, a load acts as a tensile force upon the sample. The load is gradually increased until the sample begins to slide in a uniform motion.

TM 220

Belt drive and belt friction



Learning objectives/experiments

- effect of wrap angle, coefficient of friction and cable force (Eytelwein's belt friction formula)
- comparison of flat belts and V-belts
- consequences of an unadapted V-belt groove

Description

- function of a belt drive
- friction of different belt types on a metal pulley

The belt drives are machine elements that are classed as traction mechanisms in the field of transmission or conversion elements. They transfer torque and speed between guiding members such as wheels or pulleys. The motion is transferred by traction mechanisms that can only absorb tensile forces. Toothed belts and chains deliver positive transmission of movements. Traction mechanisms such as cables, flat belts and V-belts, on the contrary, allow for non-positive transmission.

In non-positive belt drives, the circumferential force between the belt and the pulley is transmitted according to the principle of cable friction.

Cable friction arises due to tangential static-friction forces at the points where the cable is in contact with the wheel or the pulley. Eytelwein's cable friction formula is used to calculate both cable and belt friction.

The TM 220 experimental unit allows the study by experiment of belt drives and belt friction. At the core of the experimental unit is a cast iron pulley, whose circumference features grooves for V-belts and flat belts. The pulley is mounted on ball bearings and is powered by a crank handle. Its flywheel mass favours an even rotation of the pulley. The belts rub on the pulley at a wrap angle between 30° and 180°. The wrap angle can be adjusted in increments of 15°.

Two spring balances detect the tensile forces on the respective belt ends. This makes it possible to precisely adjust the belt tension using a threaded spindle.

Two flat belts made of different materials, a V-belt and a cable belong to the scope of delivery. The experiments compare different belt types and materials and investigate the effect of the wrap angle.

In addition, for V-belts, it is possible to study how the groove shape affects the coefficient of friction.

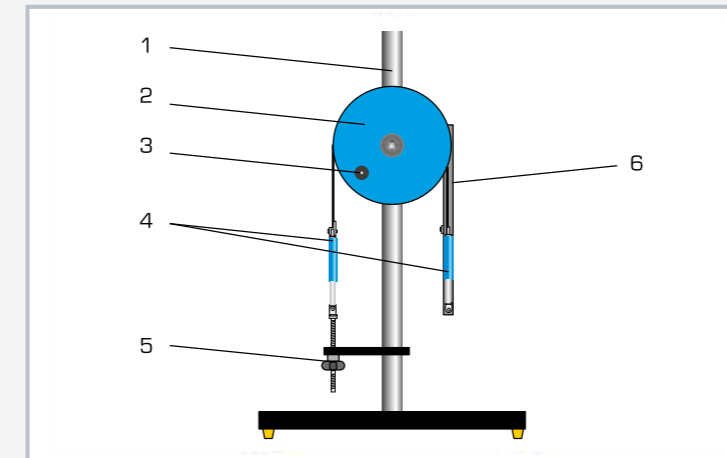

1 support column, 2 pulley, 3 crank handle, 4 spring balance, 5 belt tension adjustment, 6 pivoting belt holder

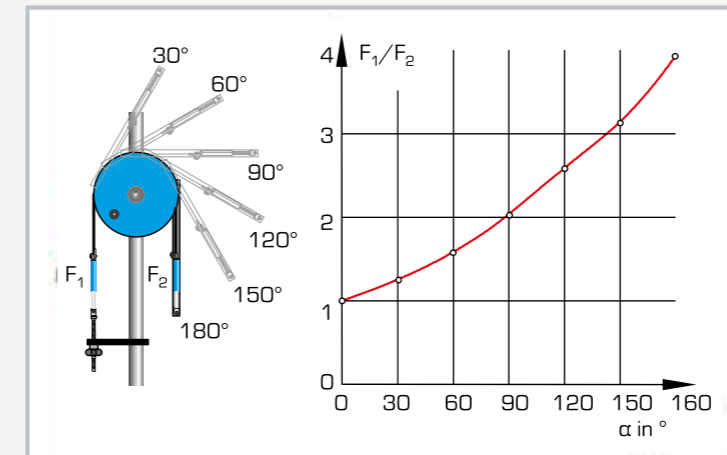

Gradual adjustment of the wrap angle from 30° to 180°. Diagram shows the force ratio F_1/F_2 as a function of the wrap angle α .

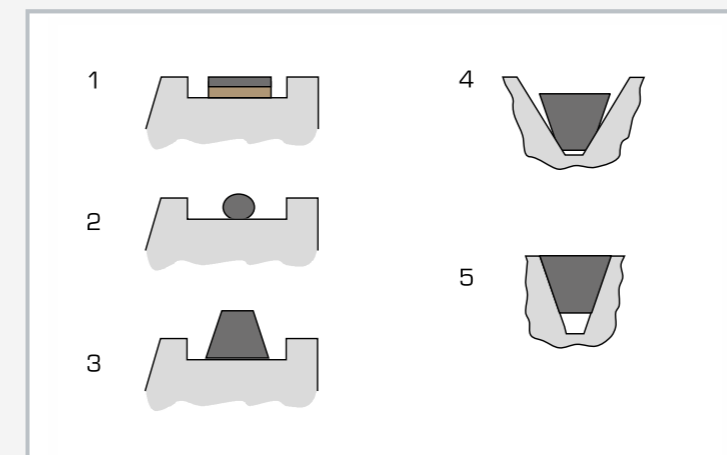

Comparison of different belt types: 1 flat belt, 2 cable, 3 V-belt, 4 adverse belt seat in the groove, 5 optimum belt seat in the groove

Specification

- [1] function of a belt drive
- [2] belt friction and comparison of different belt materials and types
- [3] ball-bearing mounted pulley with 3 different belt grooves
- [4] 2 flat belts made of different materials, 1 V-belt and 1 cable
- [5] wrap angle of the belts 30°...180°, graduation 15°
- [6] force measurement with 2 spring balances

Technical data

Flat belts

- 1x leather/polyamide, 15x2,2mm, Extremultus LT10
- 1x polyamide, 15x0,6mm, Extremultus TT2

V-belt

- ISO 4184
- profile: SPZ
- 9,7x8,0mm, rubber/fabric

Cable

- hemp, $\varnothing=3\text{mm}$

Pulley

- $\varnothing=300\text{mm}$
- material: grey iron
- Dynamometer: 100N $\pm 1\text{N}$

LxWxH: 700x350x1100mm
Weight: approx. 47kg

Scope of delivery

- 1 experimental unit
- 2 flat belts
- 1 cable
- 1 V-belt
- 2 dynamometers
- 1 set of instructional material

2 Engineering mechanics – strength of materials

Introduction

Overview Strength of materials	078
--	-----

Elastic deformations

Basic knowledge Elastic deformations	080
SE 110.14 Elastic line of a beam	082
WP 950 Deformation of straight beams	084
SE 110.47 Methods to determine the elastic line	086
SE 110.29 Torsion of bars	088
WP 100 Deformation of bars under bending or torsion	090
SE 110.20 Deformation of frames	092
FL 170 Deformation of curved-axis beams	094
SE 110.44 Deformation of trusses	096
TM 262 Hertzian pressure	098
TM 400 Hooke's law	100

Accessories

SE 112 Mounting frame	101
---------------------------------	-----

Buckling and stability

Basic knowledge Stability problem buckling	102
SE 110.19 Investigation of simple stability problems	104
SE 110.57 Buckling of bars	106
WP 121 Demonstration of Euler buckling	108
WP 120 Buckling behaviour of bars	110
Overview Accessories for WP 120	112

Compound stress

FL 160 Unsymmetrical bending	114
WP 130 Verification of stress hypotheses	116

Experimental stress and strain analysis

Overview Experimental stress and strain analysis	118
FL 101 Strain gauge application set	120
FL 100 Strain gauge training system	122
FL 102 Determining the gauge factor of strain gauges	124
Overview FL 152 PC-based recording and analysis of strain gauge signals	126
FL 152 Multi-channel measuring amplifier	128
FL 120 Stress and strain analysis on a membrane	130
FL 130 Stress and strain analysis on a thin-walled cylinder	132
FL 140 Stress and strain analysis on a thick-walled cylinder	134
FL 200 Photoelastic experiments with a transmission polariscope	136
FL 210 Photoelastic demonstration	138
Overview FL 200 and FL 210 Representation of stress distribution in component models	140



Strength of materials

Strength of materials is based on statics. The idealisation of a real body as a rigid body in statics allows determining the external and internal forces on structures under equilibrium. Ensuring equilibrium is not sufficient for calculating the mechanical behaviour of components, including strength, rigidity, stability, fatigue strength and ductility, in the real world of engineering practice. Knowledge of the deformability of material bodies is required, without consideration of the material.

Strength of materials deals with the effect of forces on deformable bodies. In addition, material-dependent parameters should be considered as well. An introduction to the strength of materials is, therefore, given by the concept of stress and strain and by Hooke's law, which is applied to tension, pressure, torsion and bending problems.

Basic terms of materials strength

Types of stress

Components can be subjected to stress in different ways: tension, pressure, shear stress, bending, torsion, buckling and composite stresses.

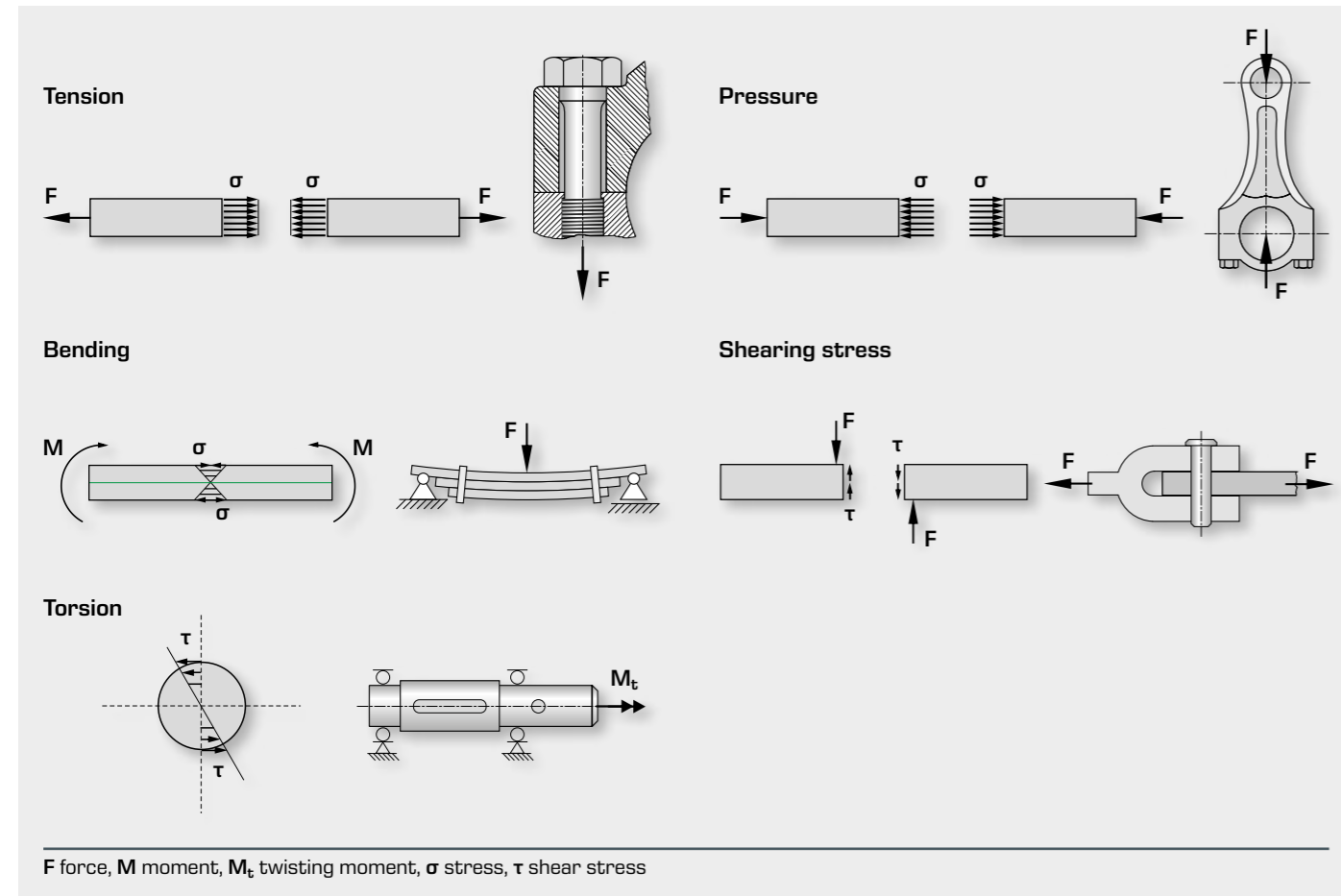

Mechanical stress

When loads, moments, or forces externally act on a component, it internally creates force flows. The distribution of these loads is called mechanical stress. Mechanical stress is, there-

fore, defined as force per unit area. We distinguish two different cases:

Perpendicular force action on the section, direct stress σ

$$\sigma = \frac{F}{A}$$

Parallel force action to the section, shear stress τ

$$\tau = \frac{F}{A}$$

F force, A section, σ stress, τ shear stress

Elastic deformation, law of elasticity

Machines and components elastically deform under the action of forces. While the load is not large enough, purely elastic deformation remains. The law of elasticity describes the elastic deformation of solids when this deformation is proportional to the applied force.

Energy methods

Geometric considerations play a subordinate role in the energy methods. Instead of the previously used equilibrium conditions, we investigate how much work is produced by external forces during deformation of a system and in which energy form and where this work is stored.

In studying the strength of materials, the energy methods are based on the law of conservation of energy and on the principle that all energy transferred to a body or a system from outside is converted to internal energy, e.g. into deformation, change in velocity, or heat.

Different energy methods are used to calculate general systems and to investigate the stability of elastic structures, such as the principle of virtual displacement, the principle of virtual forces, the Maxwell-Betti theorem, or Castigliano's theorem.

The starting point of all energy methods is the **principle of virtual work**. It expresses an equilibrium condition and states: If a mechanical system is in equilibrium under the effect of external and internal forces, then the sum of the total virtual work, produced by internal and external forces and any virtual displacement are equal to zero.

Principle of virtual work

$$\delta W = F \cdot \delta x = 0; \delta W = M \cdot \delta \phi = 0$$

$$\delta W = \sum \delta W = \sum F \cdot \delta x = 0$$

$$\delta W = \sum \delta W = \sum M \cdot \delta \phi = 0$$

δW virtual work,
 δx virtual displacement,
 $\delta \phi$ virtual twisting angle,
 M moment, F force

Experimental stress and strain analysis as proof of stresses

Strain gauge

Experimental stress and strain analysis uses the mechanical stress that occurs in components under load to determine the material stress. An experimental method for determining mechanical stress is based on the relation between stress and the deformation it causes. This deformation is known as strain and occurs on the surface of the components, which means that it can be measured. The principle of strain measurement is an important branch of experimental stress and strain analysis.

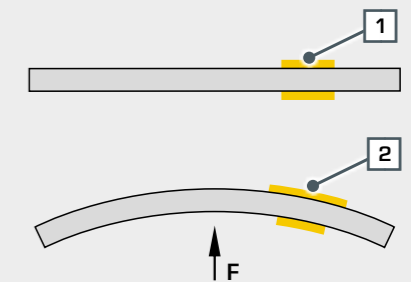

F force, 1 strain gauge in component not under load, 2 strain gauge in component under load

Photoelasticity (transmitted light polariscope)

Photoelasticity is an optical experimental method for determining the stress distribution in transparent, generally planar equivalent bodies. Photoelasticity provides a complete picture of the stress field. Areas of high stress concentration and the resulting strain as well as areas under less load can be clearly visualised.

Photoelasticity is a proven method for verifying analytically or numerically performed stress analyses (e.g.: FEM). It is used for both obtaining quantitative measurements and demonstrating complex stress states.

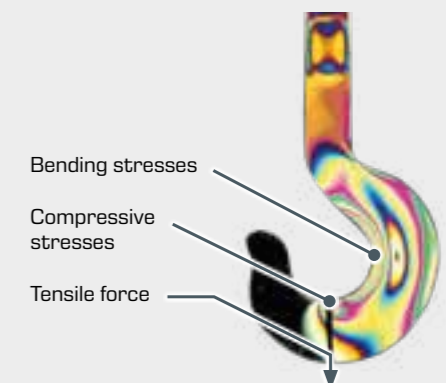

Basic knowledge Elastic deformations

Components are differently stressed when subjected to load from external forces. Load causes stresses in the components. The mesh of the material is deformed under force action, e.g. compressed and stretched. This load leads to volume or shape deformation. Unlike plastic deformation, elastic deformation

means that all atoms return to their original position once the force action ends. Different loads lead to typical component deformations.

Deformation of beams

Deflection and load-bearing capacity of beams are extremely important in practice, in structural engineering and bridge building as well as in mechanical and automotive engineering.

Deflection depends on the dimensions, material properties and especially on how the beams are mounted at the ends.

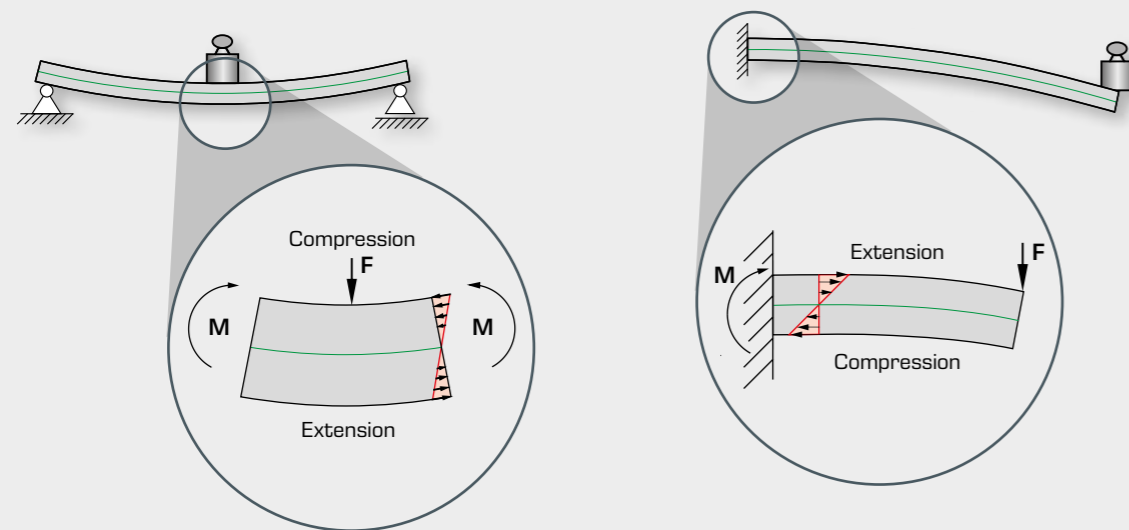

Tensile stress results in the extension of the outer strands, whereas compressive stress results in compression of the outer strands. The neutral strand (green) passes through the centroid and is neither compressed nor extended.

M moment, F force

Deformation of bars due to a twisting moment

When subject to a load due to a twisting moment, bars are twisted about their bar axis. The torsional deformation is described by the twisting angle φ . Hooke's law states that the twisting angle φ is proportional to the externally acting twisting moment.

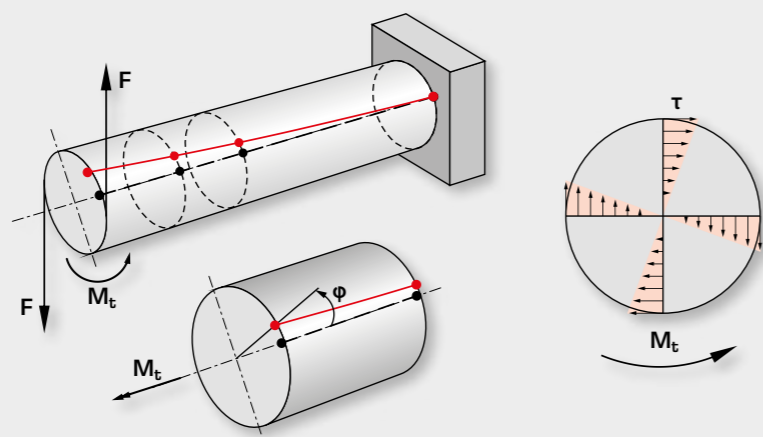

Torsional stress leads to deformation of the bar.

Mt twisting moment, F force, φ twisting angle, τ shear stress

Determination elastic behaviour

There is direct proportionality between deformation and applied force. Therefore, it is necessary to know the material properties as well as the stress to determine the strain or elastic deformation. These material properties, known as the modulus of elasticity, describe the relation between stress and strain in the deformation of a solid body with linear elastic behaviour. The elastic modulus can be calculated from the measured values of the tensile test or determined graphically

from the stress-strain diagram (also see chapter 6 Materials testing).

In strength of materials, we consider the linear-elastic region, since the deformation of the material is reversible in this region. When designing beams or supporting structures, the linear-elastic region should not be exceeded.

Elastic region of the stress-strain diagram

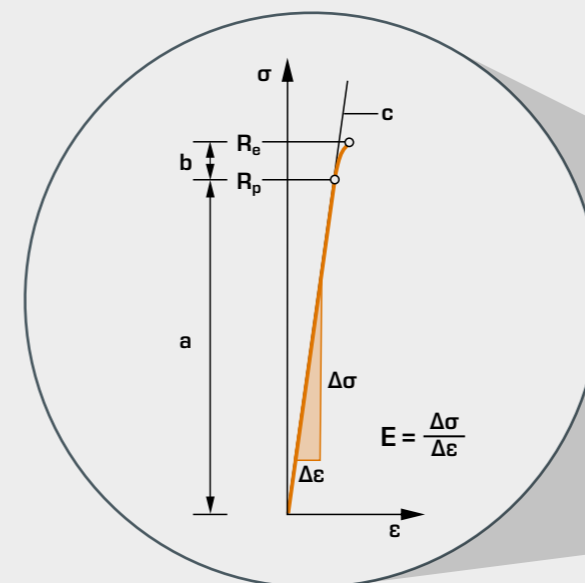

Stress-strain diagram

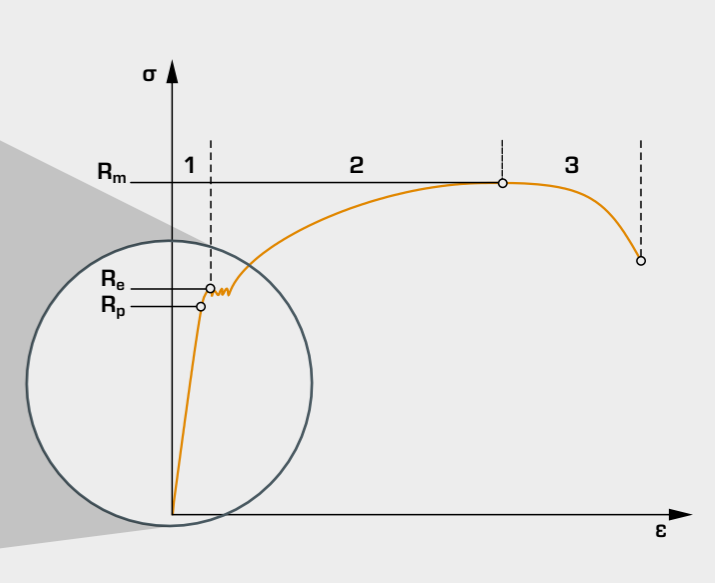

The elastic region is divided into a linear-elastic component a, where the strain is proportional to the stress and is reversible and a nonlinear-elastic component b, where the strain is not proportional to the stress but is still reversible. In the plastic region, the strain is not reversible and the deformation remains even after the force has been removed.

σ stress, ϵ strain, E elastic modulus, R_p proportional limit, R_e yield strength, R_m tensile strength, 1 elastic region, 2 plastic region, 3 constriction to fracture, a linear-elastic component, b nonlinear-elastic component, c Hooke's straight line

The calculation of deformations under load is described by Hooke's law of elasticity

$$\sigma = E \cdot \epsilon = \frac{F}{A}$$

σ stress, E elastic modulus, ϵ strain, F force, A area

Elastic modulus for various materials

Material	E in N/mm ²
steel	$2,1 \cdot 10^5$
aluminium	$0,7 \cdot 10^5$
concrete	$0,3 \cdot 10^5$
wood along the grain	$0,7 \dots 1,6 \cdot 10^4$
cast iron	$1,0 \cdot 10^5$
copper	$1,2 \cdot 10^5$
brass	$1,0 \cdot 10^5$

SE 110.14

Elastic line of a beam

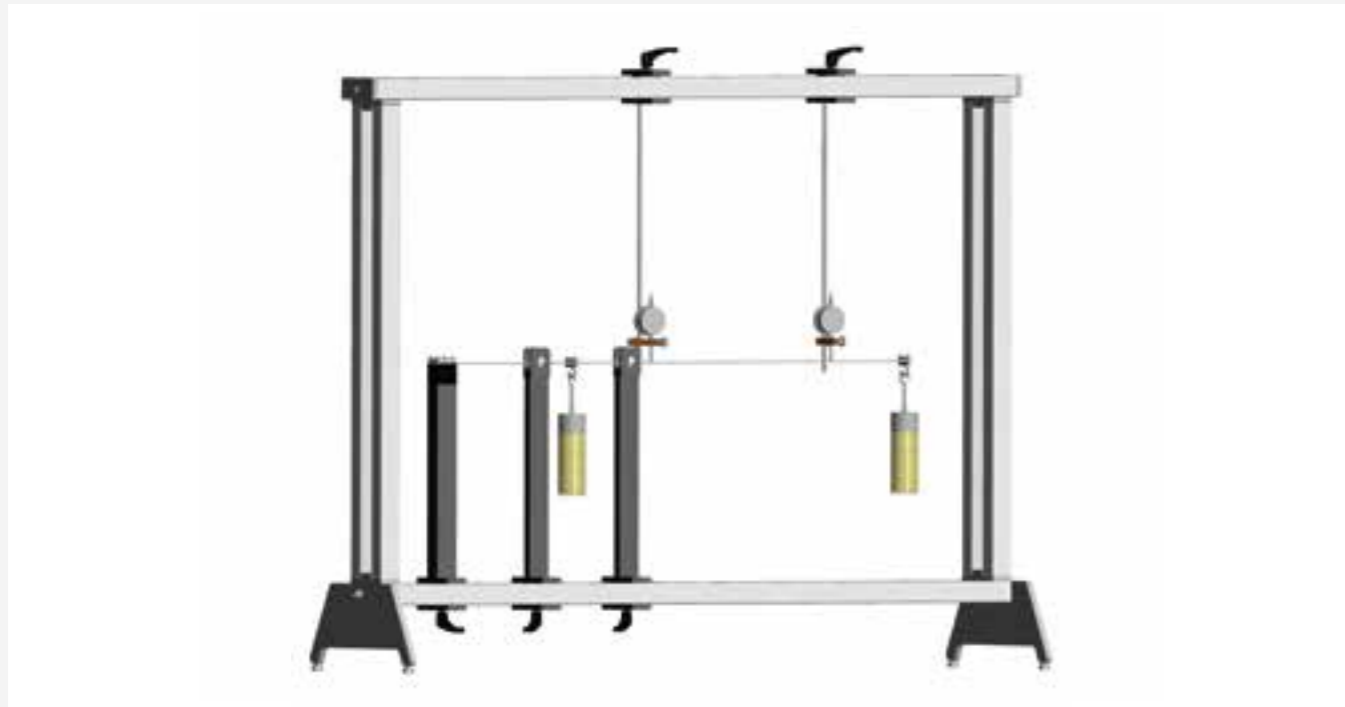

The illustration shows SE 110.14 in the SE 112 mounting frame.

Description

■ beams of different materials: steel, brass and aluminium

Beams are important design elements in mechanical engineering and building construction that can deform under load. Beams are subjected to load transversely in the axial direction, which leads to deflection. In linear-elastic material behaviour, the bending line, also known as elastic line, is used to determine the deflection of beams. Deflection can be determined at any point on the beam using the influence coefficients and Maxwell-Betti's commutative theory.

The SE 110.14 unit is used to determine the deformation of a bending beam. To do this, a beam is studied under varying loads, different support conditions and static overdetermination. The elastic line is determined by calculation and verified by experiment.

The experimental setup includes three beams made of different materials. Two pinned supports and one fixed support with clamp are available. The dial gauges record the resulting deformation of the beam. The parts of the experiment are clearly laid out and securely housed in a storage system.

The entire experimental setup is constructed in the SE 112 mounting frame.

Learning objectives/experiments

- elastic line under varying load
- elastic line under various support conditions
- demonstration of Maxwell-Betti's theorem
- elastic line and support forces in statically indeterminate systems

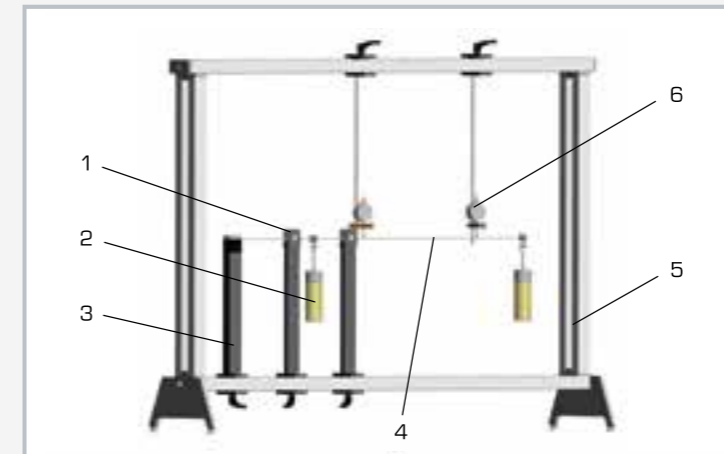

1 pinned support, 2 weight, 3 fixed support with clamp, 4 beam, 5 SE 112 frame, 6 dial gauge

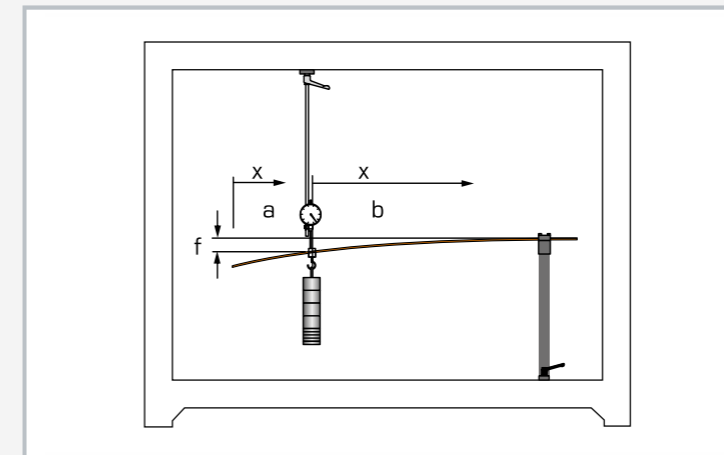

Bending on a cantilever beam: f draw down of the beam's end, x distance, a unloaded region with linear elastic line, b loaded region

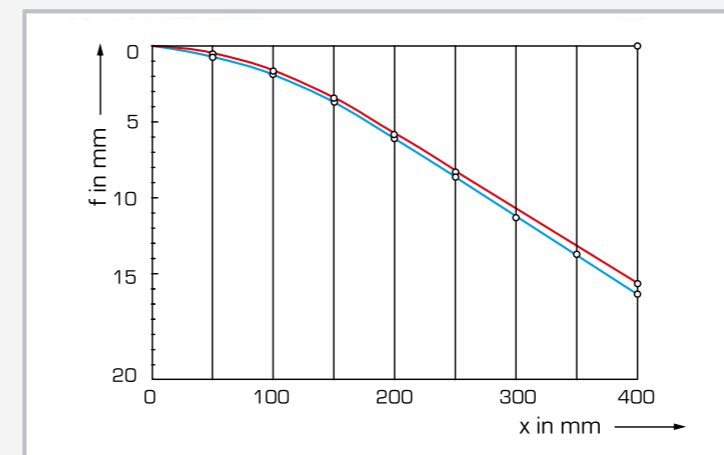

Elastic line of a cantilever beam: f draw down, x distance; red: calculated values, blue: measured values

Specification

- [1] determine the elastic line
- [2] beams of different materials: steel, brass and aluminium
- [3] 2 pinned supports
- [4] 1 fixed support with clamp
- [5] dial gauges for recording the deformation of the beam
- [6] storage system for parts
- [7] experiment setup in the SE 112 mounting frame

Technical data

Beams

- steel, LxWxH: 1000x20x3mm
- brass, LxWxH: 1000x20x6mm
- aluminium, LxWxH: 1000x20x6mm

Weights

- 2x 1N (hanger)
- 10x 1N
- 6x 5N

Measuring ranges

- travel: 0...20mm
- graduation: 0,01mm

LxWxH: 1170x480x178mm (storage system)

Weight: approx. 42kg (total)

Scope of delivery

- 3 beams
- 2 pinned supports
- 1 fixed support with clamp
- 2 dial gauges with bracket
- 1 set of weights
- 1 storage system with foam inlay
- 1 set of instructional material

WP 950

Deformation of straight beams

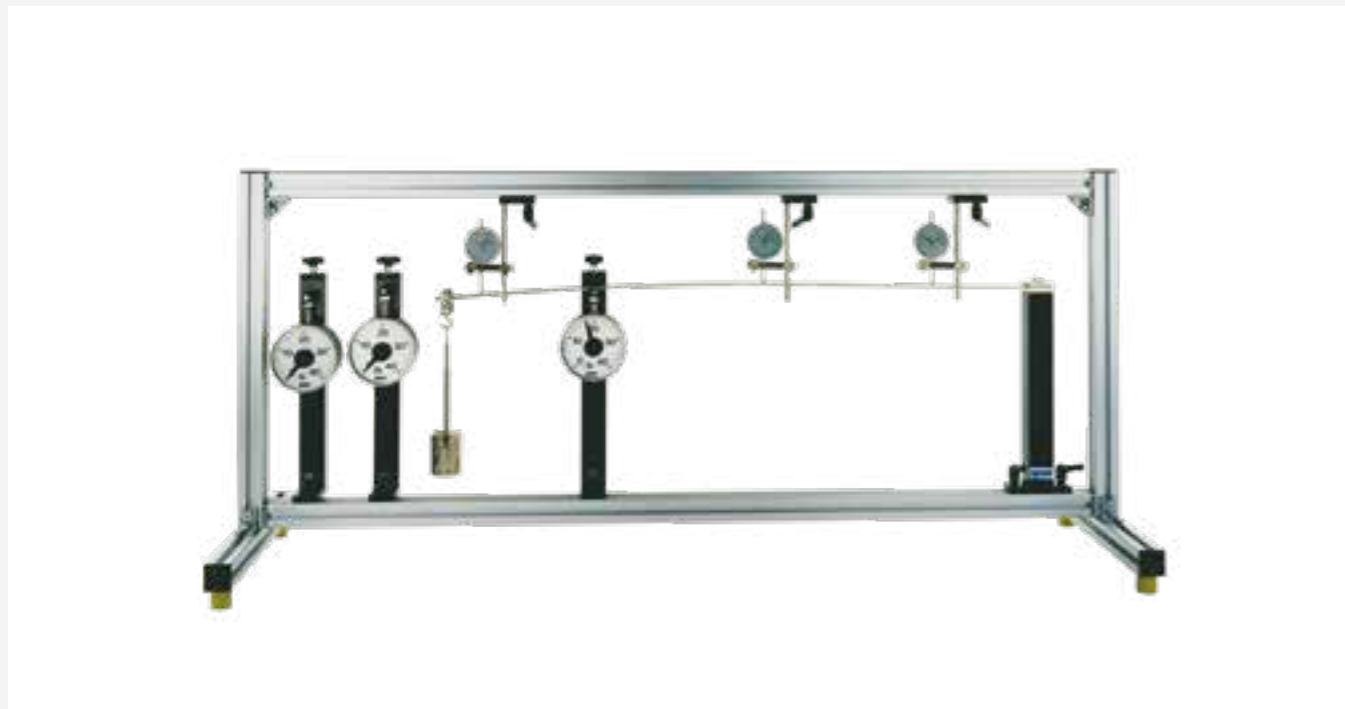

Description

- deformation of a beam on two or more supports under point loads (e.g. single-span beam)
- deformation of a cantilever beam under point loads
- statically determinate or indeterminate systems

Beams are key structural elements in mechanical engineering and in construction. A beam is a bar-shaped component in which the dimensions of the cross-section are much smaller than the length and which is subjected to load along and perpendicular to its longitudinal axis. The load perpendicular to the longitudinal axis causes a deformation of the beam – that is, bending. Based on its size, the beam is viewed as a one-dimensional model.

The science of the strength of materials deals with stress and strain resulting from the application of load to a component. Many fundamental principles of the strength of materials can be illustrated well by a straight beam.

The beam under investigation in WP 950 can be supported in different ways. This produces statically determinate and indeterminate systems which are placed under load by different weights.

The load application points are movable. Three dial gauges record the resulting deformation. Three articulated supports with integral force gauges indicate the support reactions directly. The articulated supports are height-adjustable, so as to compensate for the influence of the dead-weight of the beam under investigation. A fourth support clamps the beam in place.

Five beams of different thicknesses and made of different materials demonstrate the influence of the geometry and of the modulus of elasticity on the deformation of the beam under load.

The various elements of the experiment are clearly laid-out and housed securely in a storage system. The complete experimental setup is arranged in the frame.

Learning objectives/experiments

- investigation of the deflection for statically determinate and statically indeterminate straight beams
 - ▶ cantilever beam
 - ▶ single-span beam, dual- or triple-span beam
 - ▶ formulation of the differential equation for the elastic line
- deflection on a cantilever beam
 - ▶ measurement of deflection at the force application point
- deflection of a dual-span beam on three supports
 - ▶ measurement of the support reactions
 - ▶ measurement of the deformations
- influence of the material (modulus of elasticity) and the beam cross-section (geometry) on the elastic line
- Maxwell-Betti coefficients and law
- application of the principle of virtual work on statically determinate and indeterminate beams
- determination of lines of influence
 - ▶ arithmetically
 - ▶ qualitatively by way of force method (Müller-Breslau)

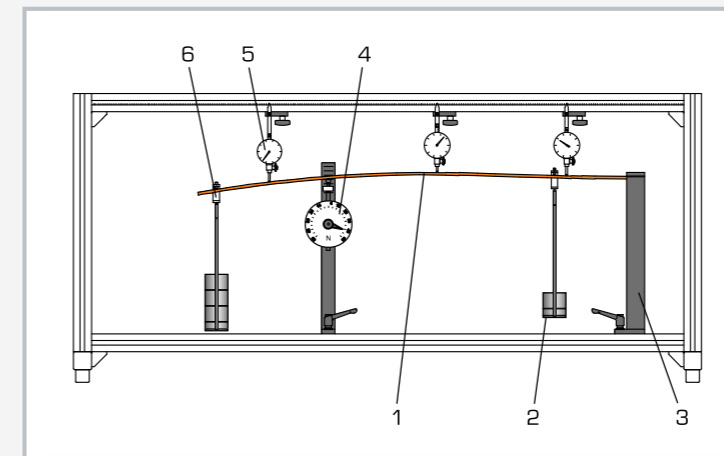

1 beam, 2 weight, 3 support with clamp fixing, 4 support with force gauge, 5 dial gauge, 6 adjustable hook

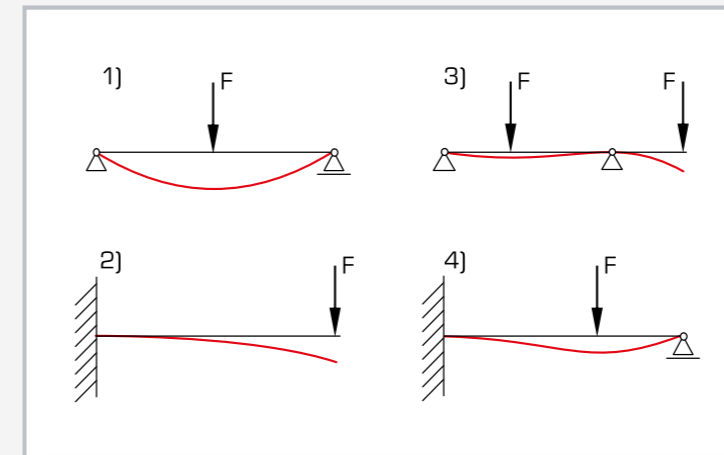

Elastic lines for statically determinate (left) and indeterminate (right) cases: 1 single-span beam with fixed and movable support, 2 cantilever, 3 beam with 2 fixed supports, 4 propped cantilever

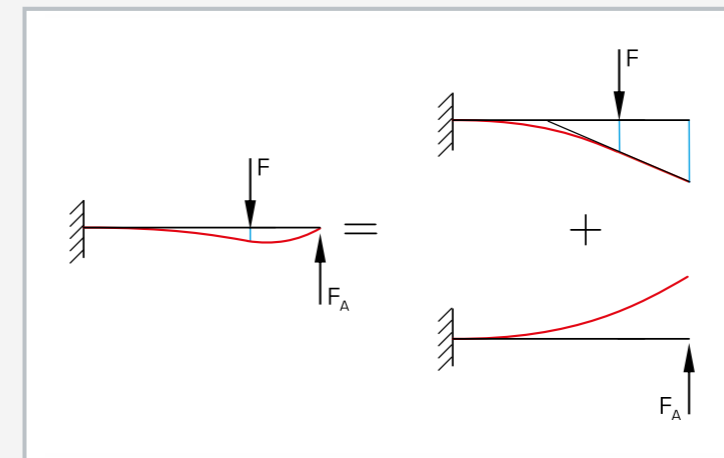

Superposition principle: the total elastic line of the statically indeterminate beam (left) is the sum of the deformations of the external force at the support (right)

Specification

- [1] elastic lines of statically determinate and indeterminate beams under various clamping conditions
- [2] 3 steel beams with different cross-sections
- [3] 1 brass and 1 aluminium beam
- [4] 3 articulated, height-adjustable supports with force gauge
- [5] 1 support with clamp fixing
- [6] force gauges can be zeroed
- [7] 3 dial gauges to record deformations
- [8] weights with adjustable hooks
- [9] anodised aluminium section frame housing the experiment
- [10] storage system to house the components

Technical data

Beam

- length: 1000mm
- cross-sections: 3x20mm (steel), 4x20mm (steel), 6x20mm (steel, brass, aluminium)

Frame opening: 1320x480mm

Weights

- 4x 2,5N (hanger)
- 4x 2,5N
- 16x 5N

Measuring ranges

- force: $\pm 50\text{N}$, graduation: 1N
- travel: 0...20mm, graduation: 0,01mm

LxWxH: 1400x400x630mm

Weight: approx. 37kg

LxWxH: 1170x480x178mm (storage system)

Weight: approx. 12kg (storage system)

Scope of delivery

- 1 frame
- 5 beams
- 4 supports
- 1 set of weights
- 3 dial gauges
- 1 set of accessories
- 1 storage system with foam inlay
- 1 set of instructional material

SE 110.47**Methods to determine the elastic line**

The illustration shows SE 110.47 in a frame similar to SE 112.

Description

- comparison of different methods to determine the elastic line: virtual work, Mohr's analogy
- statically determinate and indeterminate systems
- various load cases: point load or bending moment

Beams are key structural elements in mechanical engineering and in construction which are subject to deformation under load. In the case of a simple beam this deformation can be predicted by various methods, such as the principle of virtual work.

The beam under investigation in SE 110.47 can be supported by different bearing methods. Two supports with clamp fixings and an articulated supports with a force gauge are provided to realise statically determinate or indeterminate systems. The two supports with clamp fixings are provided with dial gauges and can also be used as articulated supports. These dial gauges enable the angle of inclination of the beam to be determined at the support. A third dial gauge records the deflection of the beam at a random point.

A device is additionally provided to generate a bending moment at a random point on the beam. A fourth dial gauge records the angle of inclination of the device.

The beam is placed under load by weights (point load and coupled forces to generate the bending moment). The clamping moment on the supports can be determined by means of weights.

The various elements of the experiment are clearly laid-out and housed securely in a storage system. The complete experimental setup is arranged in the frame SE 112.

Learning objectives/experiments

- elastic lines for statically determinate or indeterminate beams under load
- determination of the elastic line of a beam by
 - ▶ the principle of virtual work (calculation)
 - ▶ Mohr's analogy (area moment method devised by Mohr; graphical representation)
- application of the principle of superposition
- determination of the
 - ▶ maximum deflection of the beam
 - ▶ angle of inclination of the beam
- comparison between calculated and measured values for angle of inclination and deflection

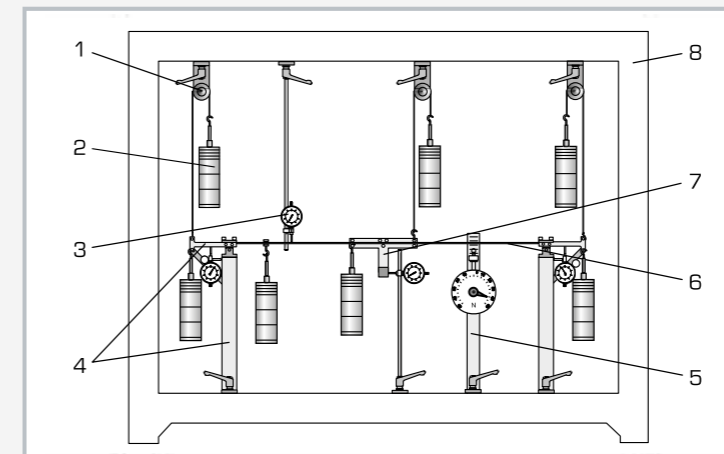

1 deflection roller with fixture, 2 weight, 3 dial gauge, 4 support with clamp fixing and dial gauge, 5 support with force gauge, 6 beam, 7 device to generate the bending moment, 8 frame SE 112

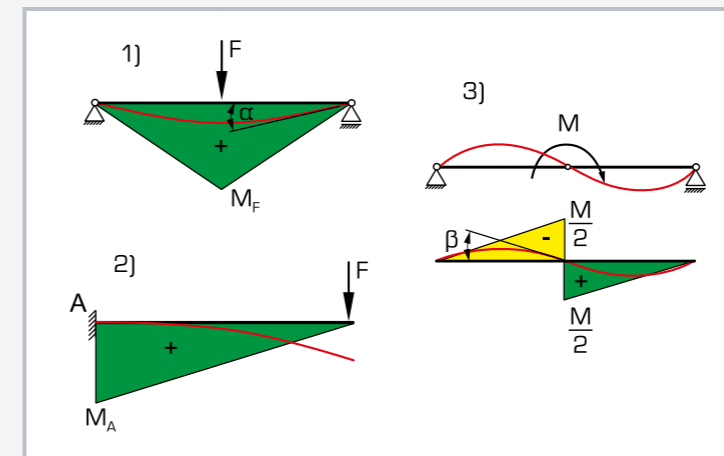

Bending moment characteristic (green/yellow) and elastic line (red) for statically determinate beams: 1 single-span beam with mid point load, 2 cantilever beam with point load, 3 single-span beam with bending moment as load; M_A bending moment on support A, M_F bending moment resulting from force F , M bending moment, α , β angle of inclination

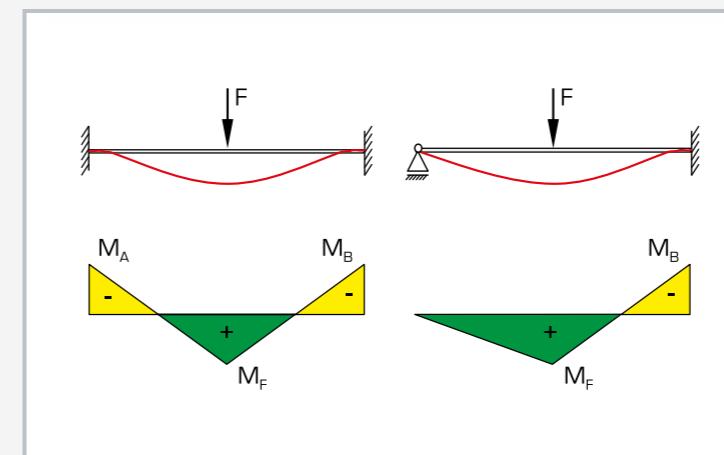

Bending moment characteristic (green/yellow) and elastic line (red) for statically indeterminate beams with centralised point load

Specification

- [1] comparison of different methods to determine the elastic line
- [2] statically determinate or indeterminate beam
- [3] 2 supports with clamp fixing, optionally as articulated support with measurement of angle of inclination or clamp fixing
- [4] 1 articulated support with force gauge
- [5] device to generate a bending moment
- [6] dial gauge with generation of moment to measure the angle of inclination
- [7] dial gauge to record the deformations of the beam
- [8] weights to subject the beam to point loads or moment
- [9] weights to determine the clamping moments on the supports with clamp fixings
- [10] storage system to house the components
- [11] experimental setup in frame SE 112

Technical data**Beam**

- length: 1000mm
- cross-section: 20x4mm
- material: steel

Weights

- 7x 1N (hanger)
- 28x 1N
- 21x 5N

Measuring ranges

- force: $\pm 50\text{N}$, graduation: 1N
- travel: 0...20mm, graduation: 0,01mm

LxWxH: 1170x480x178mm (storage system)

Weight: approx. 42kg (total)

Scope of delivery

- 3 beams
- 2 supports with clamp fixings
- 1 support with force gauge
- 1 device to generate the bending moment
- 1 set of weights
- 3 deflection rollers with fixture
- 3 cables
- 2 dial gauges with bracket
- 1 storage system with foam inlay
- 1 set of instructional material

SE 110.29

Torsion of bars



The illustration shows SE 110.29 in the frame SE 112.

Description

- elastic torsion of a bar under a torque
- round bar, tube, longitudinally slotted tube and square tube as test bars
- indication of the angle of twist at two random points on the bar

Torsion occurs primarily on axles and drive shafts in motor vehicles and machines. The torsion occurring in the shaft cause cross-sections of the shaft to be pushed together around the longitudinal axis. When a torque is applied to a shaft the cross-section remains flat and no warpage occurs.

In the event of minor torsion the length and radius remain unchanged. The straight lines on the outer circumference of the shaft running parallel to the axis become helices. Non-circular cross-sections mostly result in warpage.

SE 110.29 investigates the torsion of a bar under a torque. The bar is clamped into two movable support blocks by a chuck. The torque is generated by a circular disk, a deflection roller and a weight.

The clamping length and torque can be varied. The resultant torsion is read-off at two random points on the bar by means of angle indicators.

The fundamentals of elastic torsion are illustrated by the round bar. Three other bars are provided in order to investigate special cases: two thin-walled enclosed sections (a tube and a square tube) and a longitudinally slotted tube (thin-walled open section).

All the component elements of the experiment are clearly laid-out and housed securely in a storage system. The complete experimental setup is arranged in the frame SE 112.

Learning objectives/experiments

- torsion of a bar
- shear modulus of elasticity and second polar moment of area
- angle of twist dependent on clamping length
- angle of twist dependent on torque
- influence of rigidity on torsion
 - ▶ round bar with full cross-section
 - ▶ tube
 - ▶ tube, longitudinally slotted
 - ▶ square tube
- calculation of angle of twist
- comparison of calculated and measured angle of twist

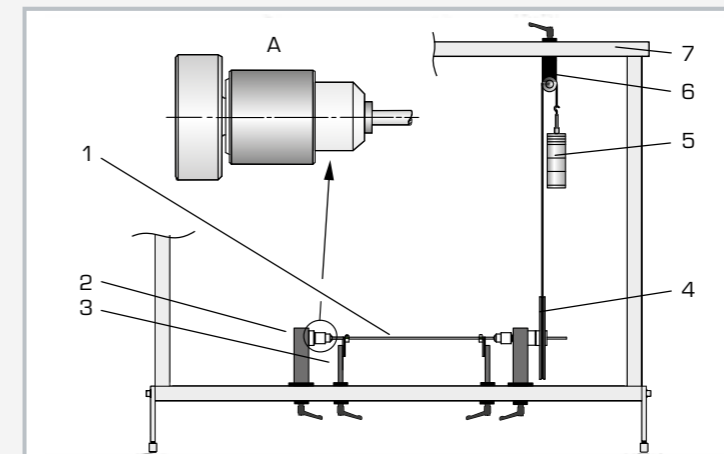

1 bar, 2 support block with clamping chuck, 3 angle indicator, 4 disk to apply moment, 5 weight, 6 deflection roller with fixture, 7 frame SE 112, A: clamping chuck

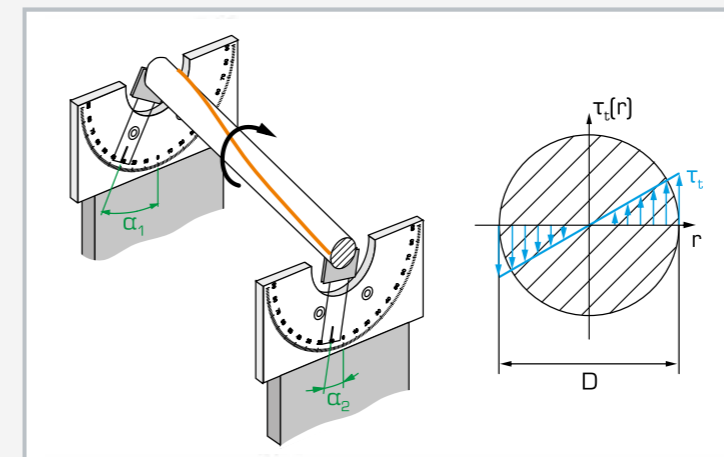

Torsion of a bar and measurement of the angles α_1 and α_2 , right: shear stresses on the circular section

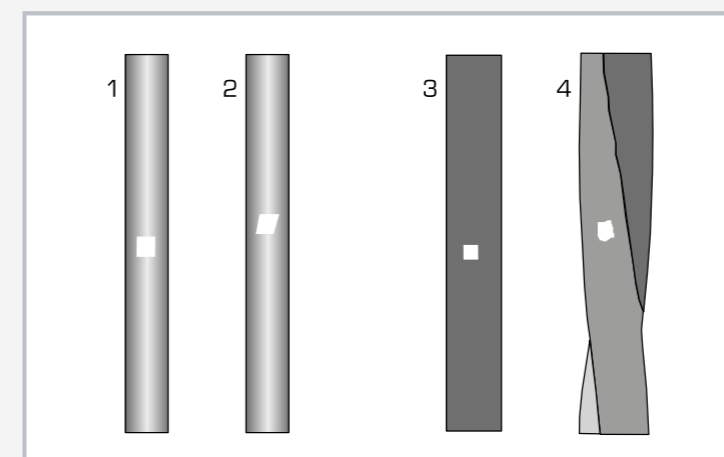

Deformation of a rectangular surface element (white): 1 round bar, not deformed, 2 round bar, twisted, 3 square tube, not deformed, 4 square tube, twisted

Specification

- [1] elastic torsion of bars
- [2] 2 movable support blocks with clamping chuck for mounting of bars, 1 fixed and 1 movable support
- [3] 2 movable angle indicators clampable to the bar
- [4] 4 bars: round bar with full cross-section, tube, longitudinally slotted tube, square tube
- [5] application of load to the bar by a mass disk, a deflection roller and weights
- [6] storage system to house the components
- [7] experimental setup in frame SE 112

Technical data

- 4 brass bars, $L=695\text{mm}$
- round bar, $\varnothing=6\text{mm}$
 - tube, slotted tube $\varnothing=6\text{mm}$, wall thickness: 1mm, slot width: 0,3mm
 - square tube $W \times H: 6\text{mm}$, wall thickness: 1mm

- Disk to apply the load
- effective radius: 110mm

- Angle indicator
- measuring range: $\pm 90^\circ$
 - graduation: 1°

- Weights
- 1x 1N (hanger)
 - 4x 1N
 - 3x 5N

$L \times W \times H: 1170 \times 480 \times 178\text{mm}$ (storage system)
Weight: approx. 27kg (total)

Scope of delivery

- 2 support blocks with clamping chuck
- 2 angle indicators
- 4 bars
- 1 deflection roller with fixture
- 1 cable
- 1 set of weights
- 2 hexagon socket wrenches
- 1 storage system with foam inlay
- 1 set of instructional material

WP 100

Deformation of bars under bending or torsion



Description

- elastic deformation of statically determinate or indeterminate beams under bending load
- elastic torsion of round bars under twisting moment
- influence of material, cross-section and clamping length on deformation

Bending and torsion are typical loads to which components are subjected. The resultant stresses and deformations can lead to failure of the component. A number of different factors play a role in this, including the material, the cross-section of the bar, the clamping length and the method of bearing support.

WP 100 investigates the influence of these factors on the deformation of a bar under bending load or twisting moment. A set of test bars has been assembled so as to permit direct comparison of measuring results. The bar under investigation is fixed to two movable support blocks and loaded down by a weight.

A dial gauge records the resulting deformation. The support blocks include clamping chucks to hold the torsion bars and supports for the bars in the bend test. The supports offer a range of clamping options, enabling statically determinate or indeterminate bearing supports to be investigated.

The twisting moment is applied by a device mounted on a support block. The point of load application to generate the bending moment is adjustable.

The various elements of the experiment are clearly laid-out and housed securely in a storage system. The complete experimental setup is arranged on the frame.

Learning objectives/experiments

- bending tests
 - ▶ determination of the modulus of elasticity
 - ▶ statically determinate systems (beam mounted on two supports; cantilever beam)
 - ▶ statically indeterminate systems (dual-span beam)
 - ▶ deformation of a beam dependent on material, geometry (section width, height and length), type of support and length of span
 - ▶ formulation of proportional relationships for the deformation
- torsion tests
 - ▶ determination of the shear modulus of various materials
 - ▶ angle of twist dependent on clamping length, bar diameter
 - ▶ formulation of proportional relationships for the angle of twist

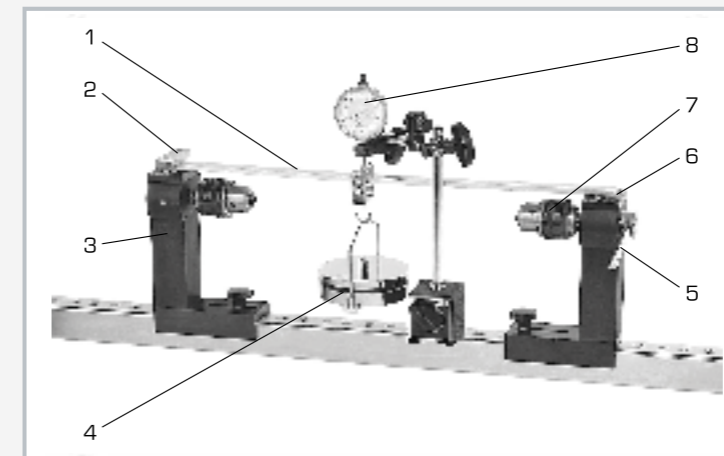

1 beam, 2 clamp fixing for bending test, 3 support block, 4 weight, 5 device to generate the twisting moment in the torsion test, 6 support for bending test, 7 clamping chuck for torsion test, 8 dial gauge

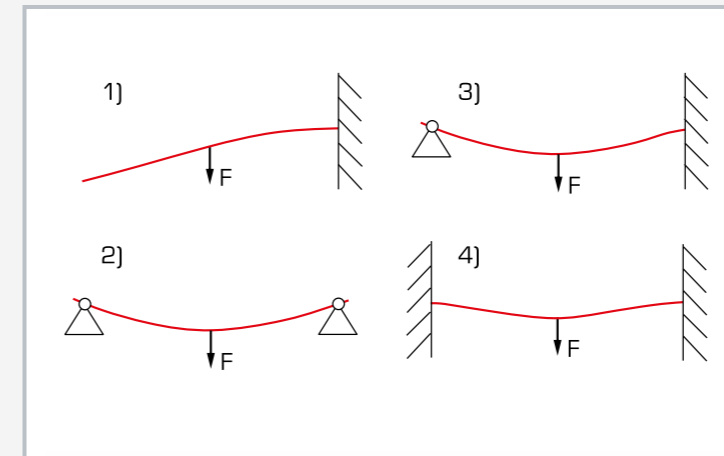

Beam deflection of a statically determinate (left) and indeterminate (right) system: 1 cantilever beam, 2 simply supported beam, 3 propped cantilever, 4 built in beam

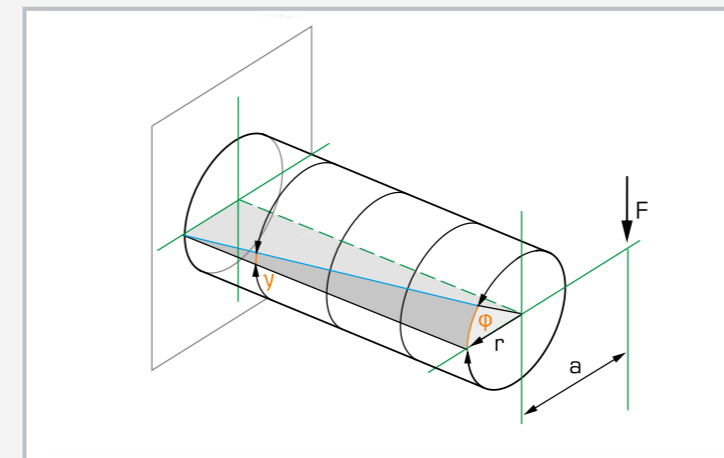

Torsion on round bar: F applied force, a lever arm, r radius, γ shear angle, ϕ angle of twist

Specification

- [1] elastic deformation of bars under bending or torsion
- [2] bending tests with statically determinate and indeterminate systems
- [3] torsion tests with a statically determinate system
- [4] supports in the bending test may be clamped or free
- [5] 2 adjustable blocks with clamping chuck for torsion tests and supports for bending tests
- [6] weights to generate the bending or twisting moment
- [7] dial gauge with bracket
- [8] storage system to house the components

Technical data

17 bars for bending tests

- material: aluminium, steel, brass, copper
- height with LxW 510x20mm: $h=3\ldots 10\text{mm}$
- width with LxH 510x5mm: $w=10\ldots 30\text{mm}$
- length with WxH 20x4mm: $l=210\ldots 510\text{mm}$
- LxWxH: 20x4x510mm (Al, St, brass, Cu)
- LxWxH: 10x10x510mm (aluminium)

22 torsion bars

- material: aluminium, steel, brass, copper
- length with \varnothing 10mm: 50...640mm (aluminium)
- \varnothing L: 10x50mm/10x340mm (aluminium, steel, copper, brass)
- diameter with L=50/340mm: \varnothing 5...12mm (steel)

Dial gauge

- 0...10mm, graduation: 0,01mm

Tape measure

- graduation: 0,01m

Weights

- 1x 1N (hanger)
- 1x 1N, 1x 4N, 1x 5N, 1x 9N

LxWxH: 1000x250x200mm

Weight: approx. 18kg

LxWxH: 1170x480x207mm (storage system)

Weight: approx. 12kg (storage system)

Scope of delivery

- 1 frame
- 2 support blocks
- 1 device to generate the twisting moment
- 17 bars for bending test
- 22 torsion bars
- 1 dial gauge with bracket, 1 tape measure
- 1 set of weights
- 2 hexagon socket wrenches
- 1 storage system with foam inlay
- 1 set of instructional material

SE 110.20

Deformation of frames



The illustration shows SE 110.20 in the frame SE 112.

Description

- elastic deformation of a statically determinate or indeterminate frame under point load
- U-shaped and S-shaped frame
- principle of virtual work to calculate the deformation and support reaction in a statically indeterminate system

A frame is a bent beam with rigid corners which creates a so-called structure gauge. This means that it spans a gap while at the same time creating height.

SE 110.20 includes a typical U-shaped frame, such as is used in the construction of halls for example. One end is clamped into place, while the other can be loosely mounted. When the non-clamped end remains free, the statically determinate frame is investigated. A roller bearing on the non-clamped end creates a statically indeterminate frame. The frame is placed under load by weights. The load application points are movable. Two dial gauges record the deformations of the frame under load.

By applying various methods (first-order elasticity theory; the principle of superposition; and the principle of virtual work), the bending moment characteristics are ascertained for a statically determinate and indeterminate frame. From these characteristic curves and a chart for integrals (coupling table) the differential equation of the bend line is formulated. From the bend line and its derivations, displacements and the support force on the movable support can be calculated.

A second, S-shaped frame can be used to show that the various methods are applicable to any kind of frame. All the component elements of the experiment are clearly laid-out and housed securely in a storage system.

The complete experimental setup is arranged in the frame SE 112.

Learning objectives/experiments

- relationship between load application and deformation on the frame
- differences between statically determinate and statically indeterminate frames
- familiarisation with the first-order elasticity theory for statically determinate and indeterminate systems
- application of the principle of superposition
- application of the principle of virtual work on statically determinate and statically indeterminate frames
 - ▶ determination of a deformation by the principle of virtual forces
 - ▶ determination of a load by the principle of virtual displacement
- comparison of calculated and measured deformations

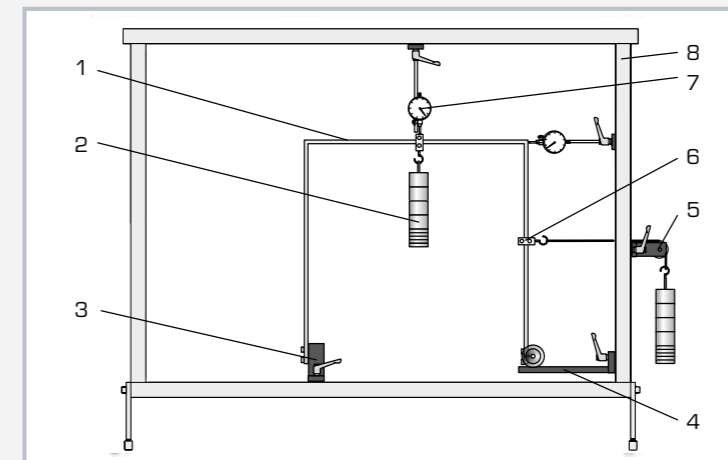

1 U-shaped frame, 2 weight, 3 short clamping pillar, 4 roller bearing, 5 deflection roller with fixture, 6 movable hook, 7 dial gauge, 8 frame SE 112

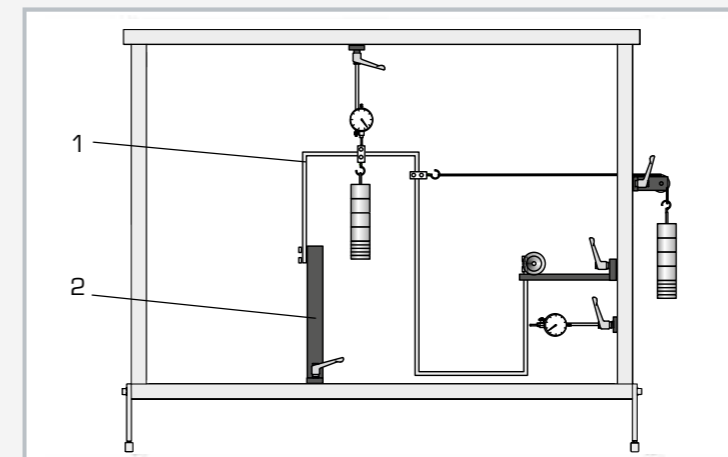

1 S-shaped frame, 2 long clamping pillar

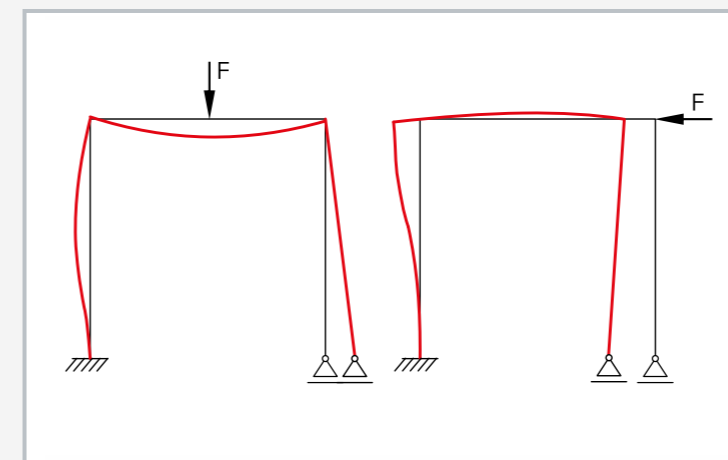

Example deformations of the statically indeterminate frame under load:
red: deformed frame; black: frame under no load

Specification

- [1] investigation of the deformation of steel frames under load
- [2] 1 U-shaped and 1 S-shaped frame
- [3] statically determinate or statically indeterminate bearing support possible
- [4] 1 long and 1 short clamping pillar
- [5] roller bearing for statically indeterminate support
- [6] weights with a movable hook to adjust to any load application point
- [7] dial gauges record the deformation of the investigated frame under load
- [8] storage system to house the components
- [9] experimental setup in frame SE 112

Technical data

- Frame made of steel
- edge length: 600mm
 - cross-section: 20x10mm
 - U-shaped: 600x600mm
 - S-shaped: 600x600mm

- Dial gauges
- measuring range: 0...20mm
 - graduation: 0,01mm

- Weights
- 2x 1N (hanger)
 - 8x 1N
 - 6x 5N

LxWxH: 1170x480x178mm (storage system)
Weight: approx. 34kg (total)

Scope of delivery

- 2 frames (1x U-shaped, 1x S-shaped)
- 2 clamping pillars (1x long, 1x short)
- 1 support
- 1 set of weights with movable hooks
- 1 deflection roller with fixture
- 1 cable
- 2 dial gauges with bracket
- 1 storage system with foam inlay
- 1 set of instructional material

FL 170

Deformation of curved-axis beams



Learning objectives/experiments

- bending behaviour of a curved-axis beam
 - ▶ circular beam
 - ▶ semi-circular beam
 - ▶ quadrant beam
- application of the principle of virtual forces (the force method) to calculate deformation
- second moment of area
- comparison of calculated and measured deformations

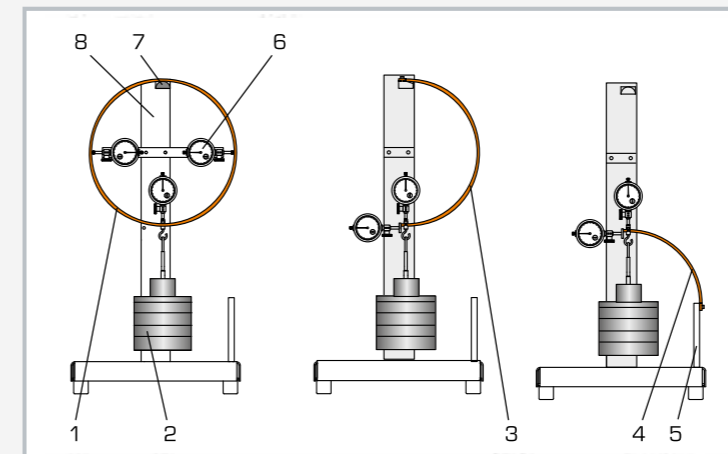

1 circular beam, 2 weight, 3 semi-circular beam, 4 quadrant beam, 5 support block, 6 dial gauge, 7 support, 8 pillar

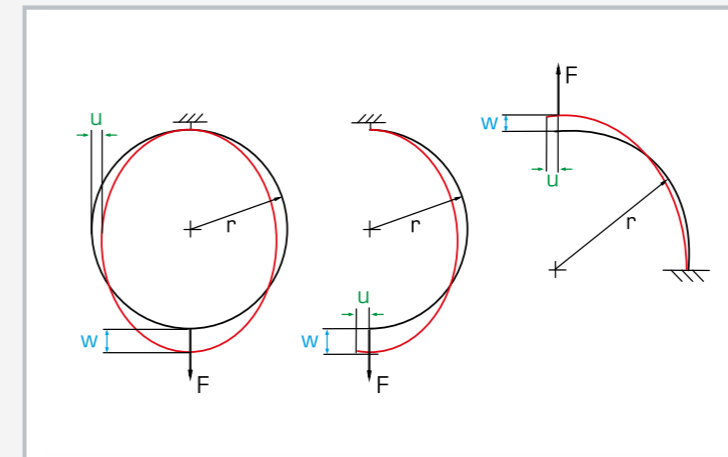

Deformations on curved-axis beams under tensile load:
F force, r radius, u horizontal displacement, w vertical displacement

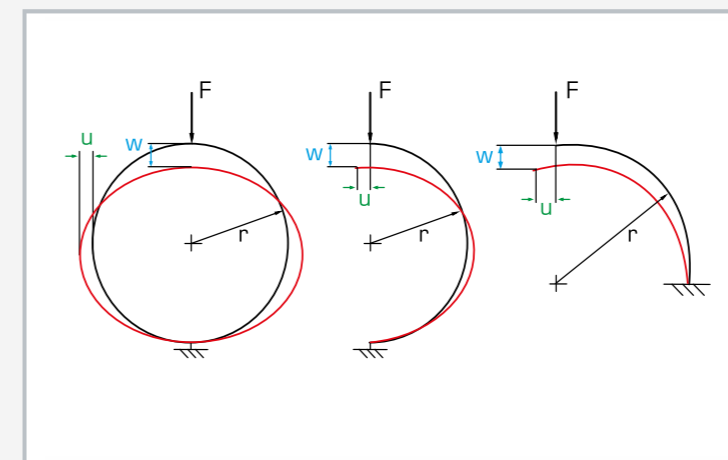

Deformations on curved-axis beams under compressive load:
F force, r radius, u horizontal displacement, w vertical displacement

Specification

- [1] elastic deformation of curved-axis beams under load
- [2] 3 different beams with the same cross-section: circular beam, semi-circular beam, quadrant beam
- [3] support block to fix the quadrant beam
- [4] pillar with support for mounting the circular or semi-circular beam
- [5] 3 dial gauges to record the horizontal and vertical deformation
- [6] storage system to house the components

Technical data

- Curved-axis beam
- radius: approx. 150mm
 - cross-section WxH: 20x5mm
 - material: steel, galvanised
- Dial gauges
- measuring range: 0...20mm
 - graduation: 0,01mm

- Weights
- 1x 1N (hanger)
 - 2x 2N
 - 1x 5N
 - 1x 10N
 - 4x 20N

- LxWxH: 400x300x850mm
Weight: approx. 21kg
LxWxH: 1170x480x178mm (storage system)

Scope of delivery

- 1 base plate with pillar
- 3 beams
- 3 dial gauges
- 1 set of weights
- 2 hexagon socket wrenches
- 1 storage system with foam inlay
- 1 set of instructional material

Description

- elastic deformation of curved-axis beams
- circular, semi-circular and quadrant beams

In construction engineering, a distinction is made between beams and arches. An arch is a statically indeterminate supported structure with a curved axis and two fixed supports or clamp fixings. The supports of an arch (such as a double-articulated arch) absorb forces vertically and horizontally. The ends of the arch in the supports do not move. This produces the static arching effect of the system. In mechanical engineering, crane hooks and chain links are typical examples of a curved beam.

FL 170 includes three different beams, borne on statically determinate supports: a circular beam, a semi-circular beam and a quadrant beam.

The beam under test is loaded with weights. Dial gauges record its horizontal and vertical deformations.

All three beams have the same cross-section and so the same second moment of area. This enables test results to be directly compared. Semi-circular and circular beams are fixed to a support on the pillar. The quadrant beam is clamped into a support block.

The various elements of the experiment are clearly laid-out and housed securely in a storage system.

SE 110.44

Deformation of trusses



The illustration shows SE 110.44 in a frame similar to SE 112.

Description

- elastic deformation in a single plane truss
- construction of various truss
- application of Castigliano's first theorem

When a component is placed under load it undergoes elastic deformation. This deformation can be calculated by determining elastic lines for example. Elastic lines describe the deformation of the complete component in the form of a mathematical equation. In reality, it is often only the deformation at specific points on the component which is of interest. Energy methods can be applied to determine these deformations more simply. Castigliano's first theorem uses energy methods to calculate the deformation of a point on the component. The theorem is applicable to both statically determinate and indeterminate systems.

In SE 110.44 the deformation of a single plane truss at one point is determined using Castigliano's first theorem. The truss under investigation is made of bars joined together by a articulated construction using node disks.

The trusses can be considered as ideal trusses. The bars have special snap-lock fixtures on their ends allowing them to be fixed easily into the node disks. A load application device attached to a node disk generates an external force.

The range of different bar lengths provided permits three forms of truss to be constructed. The bars are made of PVC, so their deformations are clearly visible.

All the component elements of the experiment are clearly laid-out and housed securely in a storage system. The complete experimental setup is arranged in the frame SE 112.

Learning objectives/experiments

- elastic deformation of truss under point load
- calculation of support reaction and bar forces
- principle of work and strain energy
- application of Castigliano's first theorem to calculate the deformation at a defined point
- verification of the calculated deformation possible by the principle of virtual work
- comparison of the deformations of different trusses under the same load
- comparison of measured and calculated deformation

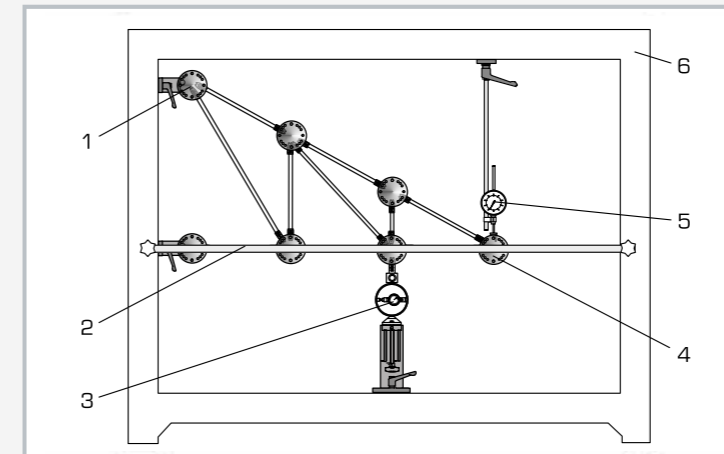

1 support with node disk, 2 cross arm for lateral stability of truss, 3 load application device with force gauge, 4 node disk, 5 dial gauge, 6 frame SE 112

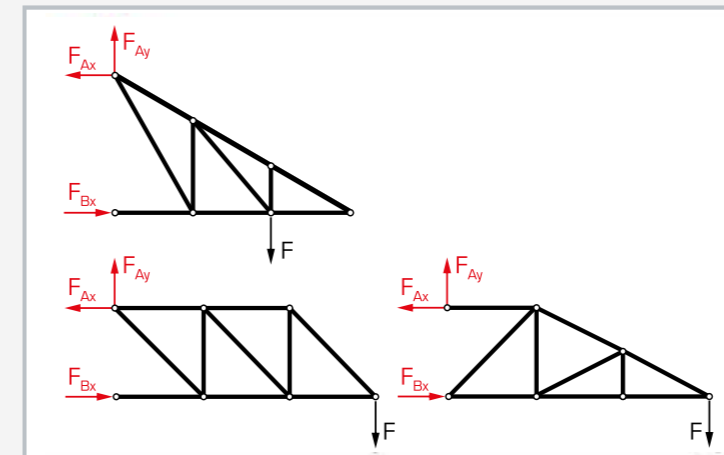

3 truss forms: red: support reactions, black: external force

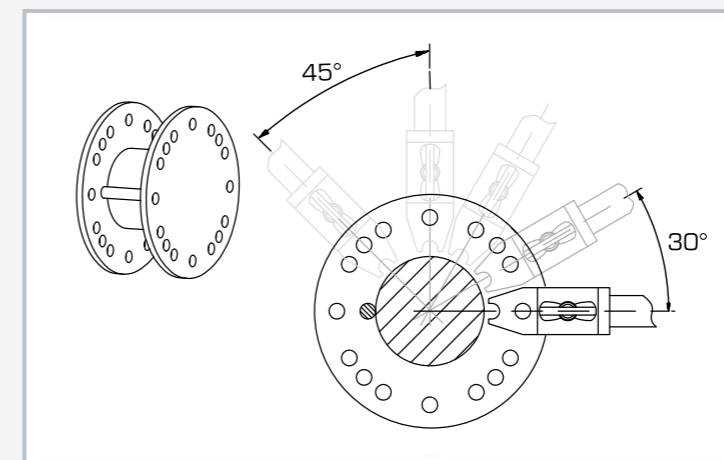

Fixing of the bars in the node disk

Specification

- [1] investigation of the deformation of statically determinate trusses
- [2] construction of different truss forms possible
- [3] 2 supports with node disks
- [4] load application device with force gauge mountable on different node disks
- [5] dial gauge to record the deformation of the truss under load
- [6] cross arm for lateral stability of truss
- [7] storage system to house the components
- [8] experimental setup in frame SE 112

Technical data

Truss with 19 PVC bars

- height of truss: max. 450mm
- length of truss: max. 900mm
- bar lengths: 2x 150mm, 5x 259mm, 7x 300mm, 1x 397mm, 3x 424mm, 1x 520mm
- angle between bars: 30°, 45°, 60°, 90°
- maximum bar force: 200N

Load application device

- measuring range: $\pm 500\text{N}$
- graduation: 10N

Dial gauge

- measuring range: 0...0,10mm
- graduation: 0,01mm

LxWxH: 1170x480x178mm (storage system)

Weight: approx. 26kg (total)

Scope of delivery

- 1 set of bars
- 5 node disks
- 2 supports with node disk
- 1 load application device
- 1 dial gauge with bracket
- 1 storage system with foam inlay
- 1 set of instructional material

TM 262

Hertzian pressure



Learning objectives/experiments

- resulting shape of the contact area under point contact with different radii of curvature
- shape of the contact area as a function of the contact force
- influence of an additional transverse component of the contact force

Description

- demonstration of the contact area under Hertzian pressure
- generation of circular or elliptical contact areas
- especially clear results due to pairing transparent plastic with silicone rubber

When two bodies with a convex surface are pressed against each other, ideally, these bodies only come into contact linearly or at one or more points. In the real world, as the two bodies approach each other, an elliptical contact area occurs at the contact point due to deformation. In this case, the compressive stresses (compression) are proportionally distributed to the deformations.

Heinrich Hertz, a physicist, developed a theory to calculate the largest pressure, also known as Hertzian pressure. The size and shape of the contact areas and the extent and distribution of the mechanical stresses under the contact areas can also be calculated.

The TM 262 experimental unit demonstrates the shape of the occurring contact area under Hertzian pressure as an example. A rubber pressure pad is pressed against a transparent plastic plate via a lever. The plate and pressure pad are curved. Both circular and elliptical contact areas can be generated.

Using a spring balance, the force is measured at the lever and the contact force is determined. A halogen lamp at one side perfectly illuminates the contact area. Grid lines on the plastic plate make it easier to measure the contact area.

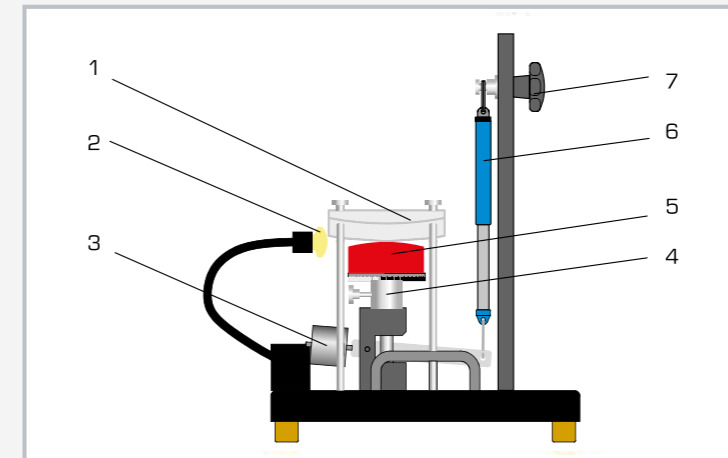

1 double convex plexiglas disk, 2 halogen lamp, 3 sliding weight to compensate the mass of the load mechanism, 4 load mechanism, 5 rubber pressure pad with convex surface, 6 spring balance, 7 movable device for the spring balance

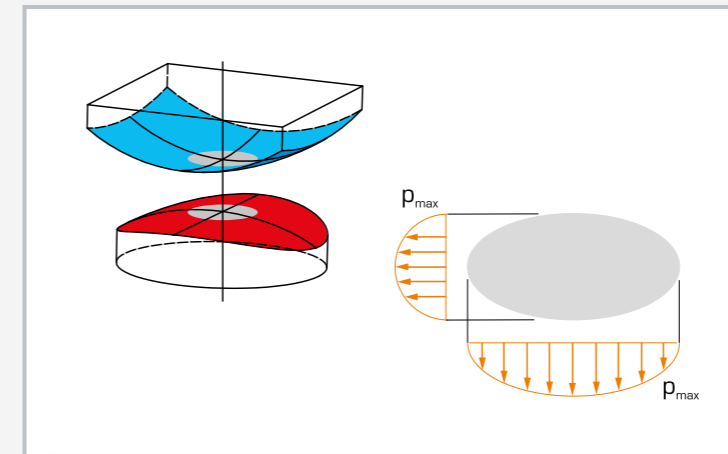

Contact area between two bodies with curved surfaces;
grey: contact area in the shape of an ellipse, orange compressive force (pressure)

Specification

- [1] demonstration of Hertzian pressure
- [2] silicone rubber pressure pad
- [3] transparent plastic plate with grid lines makes it easier to measure the contact area
- [4] spring scale to measure force
- [5] movable device for the spring balance to generate a continuously adjustable contact force
- [6] optimum illumination of the contact area by side-mounted halogen lamp

Technical data

Spring balance
 ■ 0...25N
 ■ graduation: 0,5N

Pressure pad
 ■ 60 Shore

Halogen lamp
 ■ voltage: 12V
 ■ power: 20W

230V, 50Hz, 1 phase
 230V, 60Hz, 1 phase; 120V, 60Hz, 1 phase
 UL/CSA optional
 LxWxH: 400x400x530mm
 Weight: approx. 16kg

Scope of delivery

- 1 experimental unit
- 1 spring balance
- 1 halogen lamp
- 1 set of instructional material

TM 400

Hooke's law



The illustration shows two TM 400 units

Description

■ elastic behaviour of tension springs under load

Hooke's law describes the elastic behaviour of components where deformation is proportional to the load acting upon them. This behaviour is typical for metals under light loads.

TM 400 demonstrates the application of Hooke's law and shows the deformation of tension springs under load.

For this purpose, a spring is suspended from a stand and loaded. The elongation is read-off directly from a scale. As a linear relationship is shown between the active force and the elongation of the spring, Hooke's law can be applied.

Learning objectives/experiments

- investigation of the proportionality of the active force and the spring deflection
- determination of the spring constant
- series configuration of two tension springs
- investigation of the influence of the spring constant on the frequency of a spring-mass system

Specification

- [1] experiments relating to Hooke's law and oscillation experiments on a spring-mass system
- [2] metal stand with integral scale
- [3] 2 helical spring as tension springs
- [4] tension springs configured in series or singly
- [5] load applied to tension spring by weights
- [6] storage system to house the components

Technical data

Helical spring short

- coils: 53
- $\varnothing=18,3\text{mm}$
- wire diameter: $\varnothing=1,0\text{mm}$

Helical spring long

- coils: 109
- $\varnothing=18,3\text{mm}$
- wire diameter: $\varnothing=1,0\text{mm}$

Scale, graduation: 1 mm

Weights

- 1x 1N (hanger)
- 10x 0,5N

LxWxH: 250x250x900mm

Weight: approx. 5kg

LxWxH: 1170x480x178mm (storage system)

Weight: approx. 12kg (storage system)

Scope of delivery

- 1 stand
- 2 helical springs
- 1 set of weights
- 1 storage system with foam inlay
- 1 set of instructional material

SE 112

Mounting frame



Description

■ mounting frame for setup of experiments in statics, strength of materials and dynamics

The mounting frame SE 112 provides a clearly laid-out, user-friendly means of setting up experiments in the fields of statics, strength of materials and dynamics.

SE 112 comprises four steel sections which are bolted together to form a frame. Two feet on the sides provide stability. The frame is quick and easy to assemble, with just a few actions needed.

Specification

- [1] frame for mounting of experiments in statics, strength of materials and dynamics
- [2] sturdy sectional steel double frame, welded
- [3] easy, exact mounting of all components by precision clamp fixings
- [4] stable on laboratory desktops or workbenches
- [5] frame supplied disassembled

Technical data

Mounting frame made of steel sections

- frame opening WxH: 1250x900mm
- section groove width: 40mm

LxWxH: 1400x400x1130mm (assembled)

LxWxH: 1400x400x200mm (without mountings)

Weight: approx. 32kg

Scope of delivery

- 1 mounting frame, disassembled
- 1 set of bolts with hexagon socket wrench
- 1 instruction manual

Basic knowledge

Stability problem buckling

If slim and long components such as bars, beams and columns are subject to compressive stress owing to a force along the bar axis, these can end up in indifferent or unstable equilibrium positions. If the force F is less than the critical force F_K , also known as buckling force, the component is in a stable equilibrium position and there is a strength problem. If the force F

reaches the buckling force F_K of the bar, the bar suddenly starts to buckle. The components, thus, lose their ability to function. Buckling is usually a very sudden and abrupt process which causes large deformations.

Different equilibrium positions

Stable equilibrium

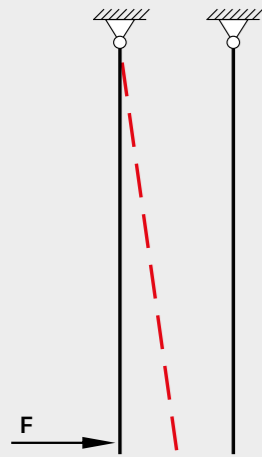

Bar returns to its starting position after the load is removed.

F force

Indifferent equilibrium

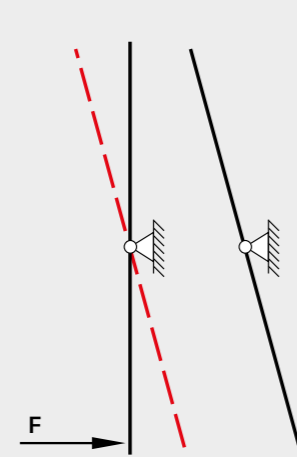

Bar remains in the new position after the load is removed.

Unstable equilibrium

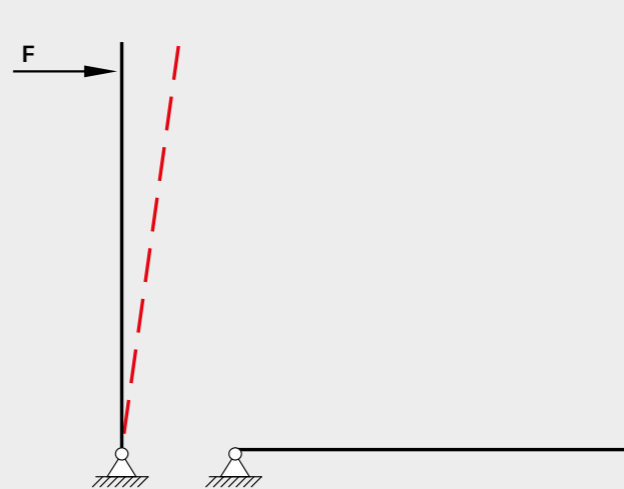

Bar does not return to the starting position after the load is removed and does not stay in the position it assumed while the load is being applied. The bar falls over.

Stability in bars

Bars under pressure are a typical stability problem. Here, we investigate when a straight bar collapses. The critical buckling force F_K describes the smallest possible compressive force under which the bar buckles. The critical buckling stress σ_K is the stress that occurs at the critical buckling force F_K . The buckling force for pressure-loaded bars depends on the support

conditions, bending stiffness and geometry of the shape of the bar cross-section. Euler's four buckling cases are taken as the basis for the study of the bending stability of bars with constant bending stiffness.

Euler's buckling cases

The mathematician and physicist Leonhard Euler defined four typical buckling cases to calculate the buckling force. For each of these cases, there is a buckling length coefficient β that is used to determine the buckling length L_K .

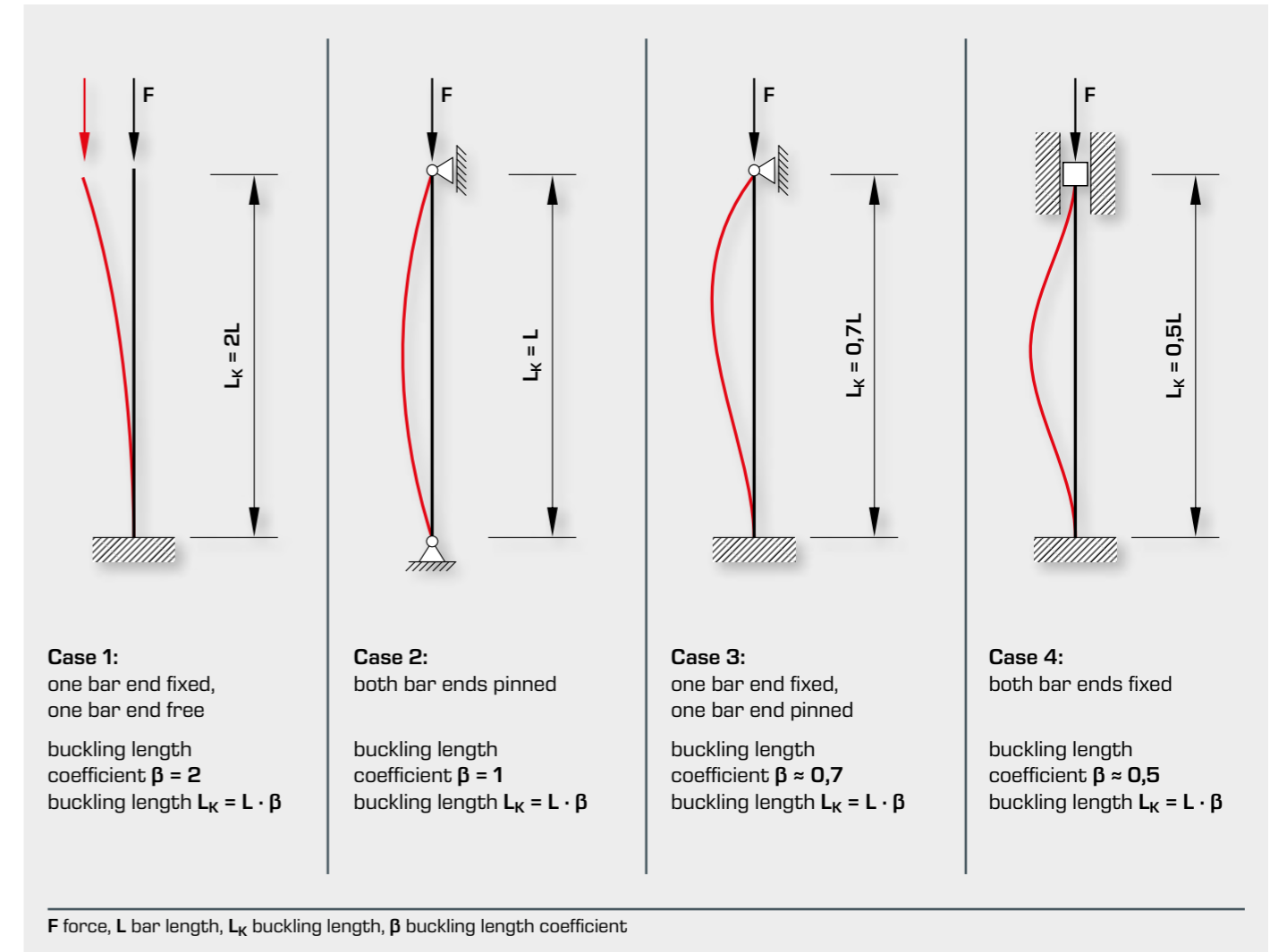
Determining the buckling force F_K

$$F_K = \frac{\pi^2 \cdot E \cdot I}{L_K^2}$$

F_K critical buckling force, L_K bar length, E elastic modulus, I axial second moment of the cross-section area

Determining the buckling stress σ_K

To determine the buckling stress we use the degree of slenderness λ as a material parameter and the moment of area radius i .

$$\lambda = \frac{\beta \cdot L}{i}$$

$$i = \sqrt{\frac{I}{A}}$$

$$\sigma_K = \frac{\pi^2 \cdot E}{\lambda^2}$$

σ_K buckling stress, E elastic modulus, λ degree of slenderness, β buckling length coefficient, L bar length, i moment of area radius, A cross-section area of the buckled bar, I second moment of area

SE 110.19

Investigation of simple stability problems



The illustration shows SE 110.19 in the frame SE 112.

Description

- representation of simple stability problems on a buckling bar
- determination of the buckling load under different conditions
- continuously variable load application on the buckling bar

Buckling is a stability problem which occurs in practice when slim components are subjected to compressive loading. Following a "disturbance" to its equilibrium, such as caused by compressive loading, a stable system returns to equilibrium when the loading is removed. If the compressive load increases excessively, instability of the system results. The component buckles and fails. The critical compressive load at which the system becomes unstable is termed the buckling force.

A simple model for representing stability problems is a two-part bar with an elastic joint which remains stable up to a certain load level. If the buckling force is exceeded, the bar suddenly buckles and so becomes unstable.

SE 110.19 is used to investigate simple stability problems on a buckling bar under different conditions. The buckling bar is in two parts, with a central articulated joint. A compressive load is applied to the bar by a lever and weights.

The continuously variable loading is determined precisely with the aid of a scale on the load application lever.

Experiments can depict a variety of conditions, such as an elastic joint or an elastic clamp fixing. Two tension springs serve as the elastic joint. The variable length of the leaf spring means various degrees of clamping are possible. The two cases can be combined.

Another experiment demonstrates the influence of additional shear forces. It involves applying a shear force to the joint in the buckling bar with a cable and a weight.

In all experiments the buckling bar is placed under load until it reaches an unstable situation. The length of the lever arm at which the buckling bar buckles is read from the scale and the buckling force is then determined.

All the component elements of the experiment are clearly laid-out and housed securely in a storage system. The complete experimental setup is arranged in the frame SE 112.

Learning objectives/experiments

- determination of the buckling force for the case of an:
 - ▶ elastic joint
 - ▶ elastic fixed end support
- investigation of the buckling behaviour under the influence of:
 - ▶ of additional shear forces
 - ▶ of pre-deformation

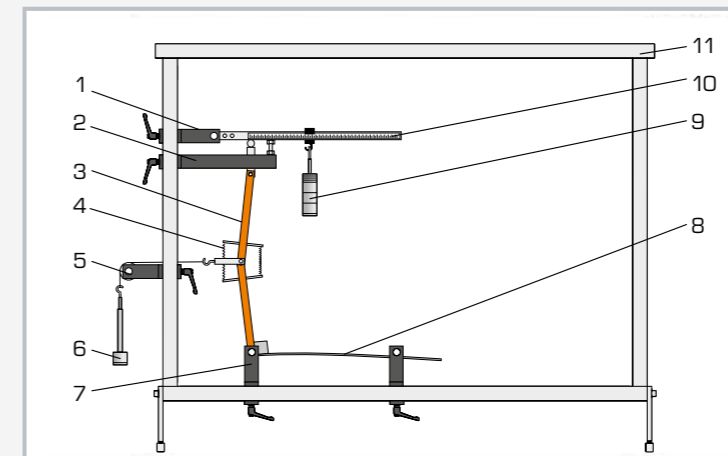

1 articulated support, 2 support with pressure pad and stop screw, 3 buckling bar, 4 articulated spring, 5 deflection roller, 6 weight, 7 articulated support, 8 leaf spring, 9 weight, 10 load application lever with scale, 11 frame SE 112

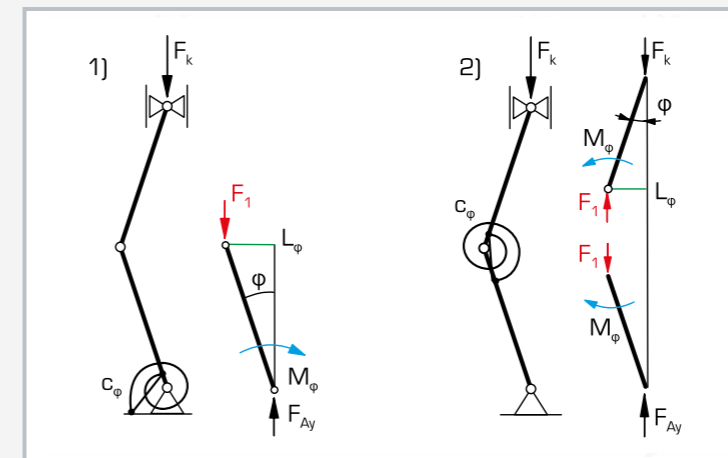

1) experimental setup for elastic support
2) experimental setup for elastic joint;
 F_k buckling force, F_1 articulation force, F_{Ay} support reaction, M_ϕ internal bending moment, L_ϕ deflection, c_ϕ torsional rigidity, ϕ deflection angle

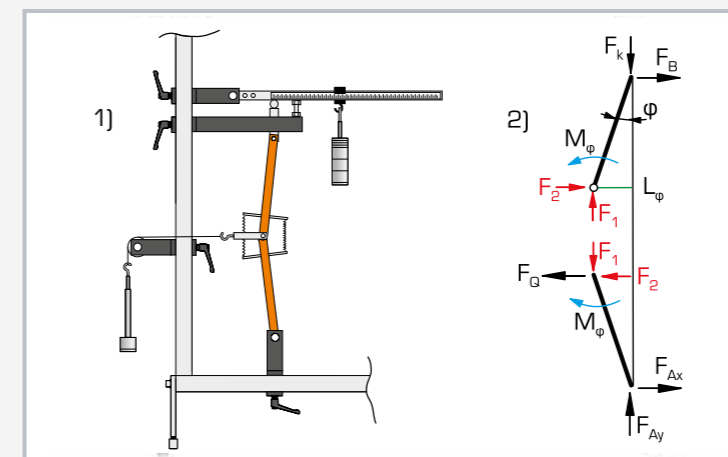

1) experimental setup for elastic joint with transverse loading
2) free-body diagram; F_G shear force, F_B and F_A support reactions, M_ϕ internal bending moment, L_ϕ deflection, ϕ deflection angle, F_k buckling force, F_1 articulation force, F_2 cable force

Specification

- [1] investigation of the buckling load under different conditions (elastic joint, elastic fixed end)
- [2] two-part buckling bar with central joint
- [3] loading continuously variable with lever and weights
- [4] determination of loading via scale on load application lever
- [5] various degrees of clamping via leaf spring with variable length on bottom support
- [6] thrust pad guided friction-free inside spherical shell
- [7] low-friction joints with roller bearings
- [8] device to generate shear forces
- [9] storage system to house the components
- [10] experimental setup in frame SE 112

Technical data

Two-part buckling bar with central joint

- WxH: 20x20mm
- length: 2x250mm
- support: pinned-pinned (articulated-articulated)

Elastic joint

- 2 tension springs, rigidity: 2N/mm
- lever arm: 50mm

Elastic clamp fixing with steel leaf spring

- length: 500mm
- cross-section: 10x2mm
- second moment of area: 6,66mm⁴
- modulus of elasticity: 205000N/mm²

Compressive force range: 25...120N

Shear force: 0...20N

Load application lever, lever ratio: 1:2...1:5

Weights

- 2x 1N (hanger)
- 8x 1N
- 6x 5N

LxWxH: 1170x480x178mm (storage system)

Weight: approx. 28kg (total)

Scope of delivery

- 1 buckling bar, two-part
- 1 set of weights
- 4 supports
- 1 deflection roller
- 1 load application lever
- 1 leaf spring
- 2 tension springs
- 1 cord
- 1 hexagon socket wrench
- 1 storage system with foam inlay
- 1 set of instructional material

SE 110.57

Buckling of bars

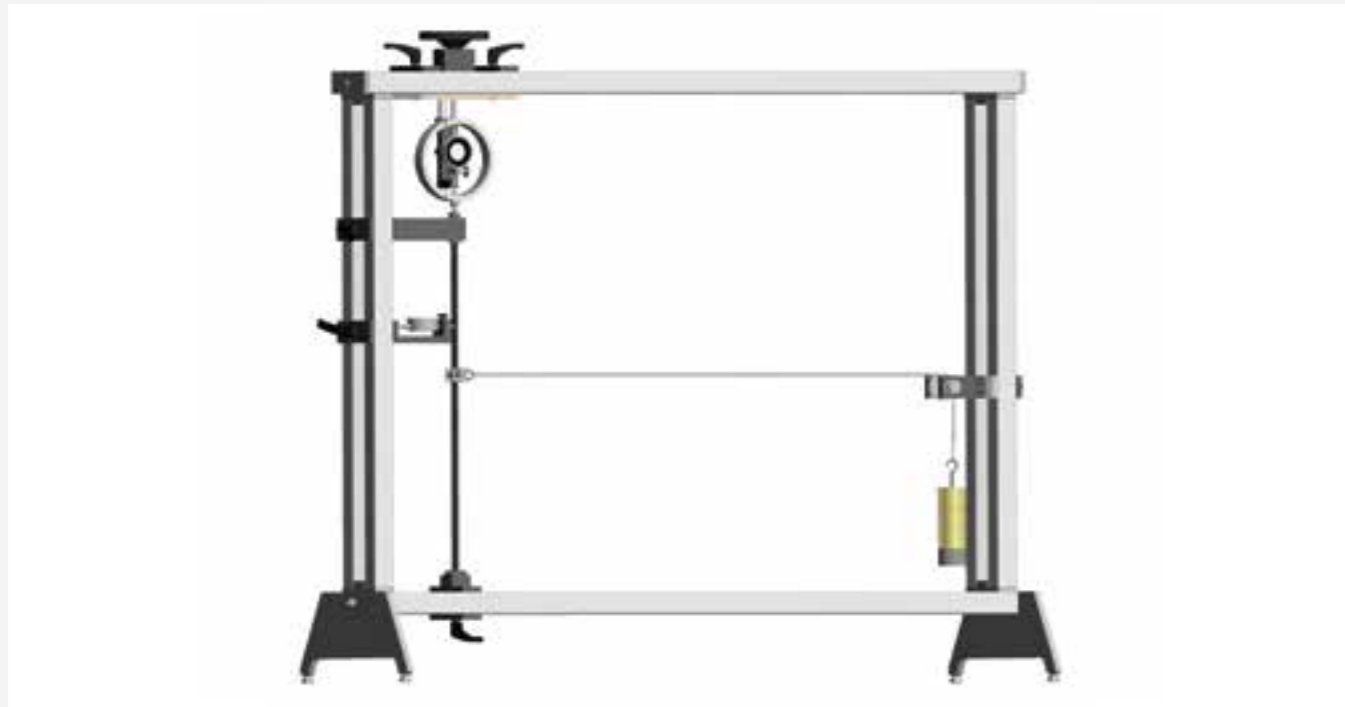

The illustration shows SE 110.57 in the SE 112 mounting frame.

Description

- demonstration of buckling in bars
- test bars made of different materials and for different support types
- experiments with eccentric application of force and shear forces

Long and slim components such as bars, beams and columns are often subjected to compressive forces along their long axis owing to their function. Under the influence of critical compressive forces, such components can lose stability and deform laterally. The technical term for this loss of stability, which occurs suddenly or continuously, is buckling. In this case, it is not the material that fails but the component shape. The stresses in the bar are often still in the elastic region.

The SE 110.57 unit can be used to clearly demonstrate the elastic buckling of bars under various influences. In this experiment, a bar is clamped or supported at both ends, depending on the buckling case. A load mechanism applies a compressive force to the bar. The applied force is measured and displayed on a force gauge. A dial gauge indicates the lateral deflection of the bar.

This experiment also demonstrates that other factors affect the buckling behaviour, such as the material and the cross-sections. Another experiment shows the influence of additional shear forces. In this experiment, a shear force is applied to the joint in the buckling bar through a cable and a weight.

The parts of the experiment are clearly laid out and securely housed in a storage system. The entire experimental setup is constructed in the SE 112 mounting frame.

Learning objectives/experiments

- investigation of buckling behaviour under the influence of
 - ▶ different supports, clamps
 - ▶ different cross-sections
 - ▶ different materials
 - ▶ additional shear forces
- testing Euler's theory: buckling on elastic bars
- measure force and displacement
- calculate the expected buckling force with Euler's buckling formula
- graphical analysis of the deflection and the force

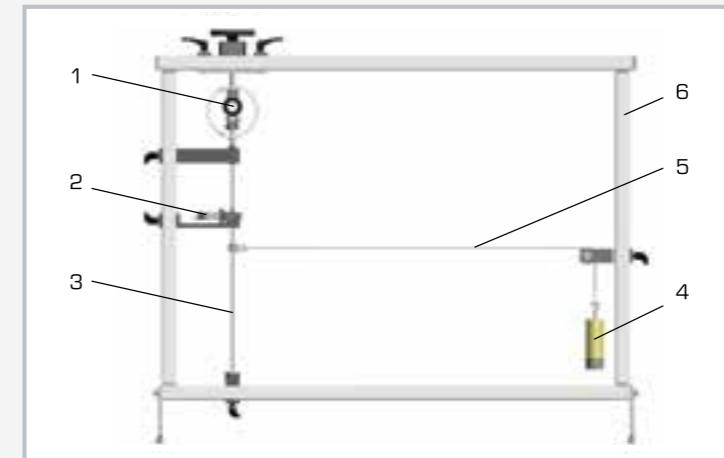

1 load mechanism, 2 dial gauges for lateral deflection of the sample bar, 3 test bar, 4 weight, 5 cable, 6 SE 112 mounting frame

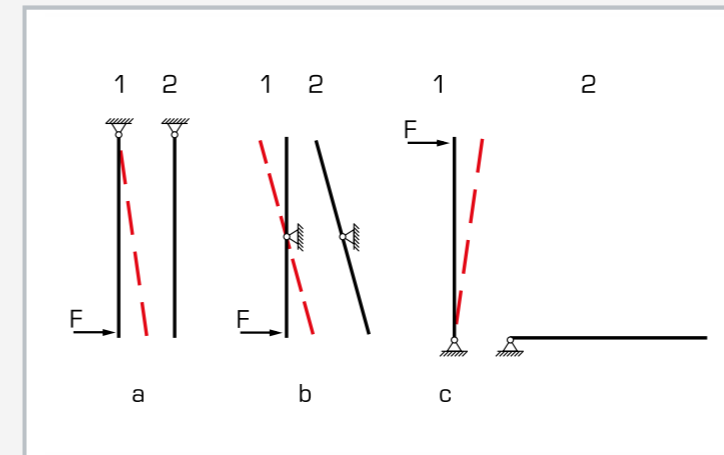

Various equilibrium positions: a stable, b indifferent, c unstable; position 1 deflection of the bar due to load, position 2 bar after load is removed

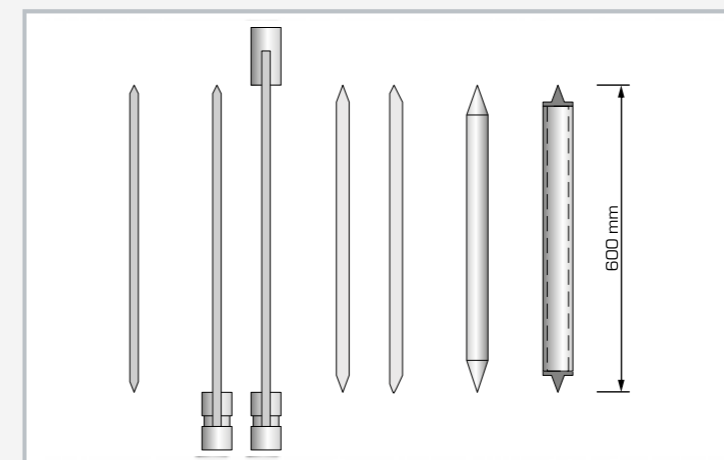

Test bars made of different materials and for different support types

Specification

- [1] clear demonstration of elastic buckling
- [2] load mechanism for applying forces
- [3] test bars pinned or fixed
- [4] devices for generating shear forces with staggered weights
- [5] measurement of lateral deflection with a dial gauge
- [6] test bars of different materials: steel and aluminium
- [7] storage system for parts
- [8] experiment setup in the SE 112 mounting frame

Technical data

Test bars

- 3x steel, LxWxH: 600x20x4mm
- 2x aluminium, LxWxH: 600x25x6mm
- 1x aluminium, LxØ: 600x10mm
- 1x aluminium, LxWxH: 600x15x2mm

Weights

- 1x 2,5N (hanger)
- 3x 5N

Measuring ranges

- force: ±5kN
- travel: 0...10mm, graduation: 0,01mm

LxWxH: 1170x480x178mm (storage system)
Weight: approx. 30kg (total)

Scope of delivery

- 1 load mechanism
- 1 set of test bars
- 1 support
- 2 dial gauges
- 1 cable
- 1 pulley
- 1 set of weights
- 1 storage system with foam inlay
- 1 set of instructional material

WP 121

Demonstration of Euler buckling



Description

- demonstration of all buckling cases of Euler buckling
- buckling length clearly visible with various methods of support
- test bars made of spring steel
- set of finely graduated weights

In stability theory, the four cases of Euler buckling represent the elastic flexural buckling of straight bars. Above a specific load – the buckling load – a loss of stability occurs and the bar increasingly changes shape. The axis of the bar is deflected laterally. Euler describes four cases for the buckling of an elastic bar with central application of compressive force and various methods of support.

WP 121 demonstrates the four cases of Euler buckling. Depending on the end conditions, different weights are required until the buckling load is reached and the axes of the bars are laterally deflected. The buckling length is clearly visible against the white backing wall with the grid patterning.

The test bars are made of stainless spring steel, and remain within the elastic range during the experiment.

The test bars are either fixed or pinned (free to rotate), depending on the chosen support method. This enables all buckling cases according to Euler to be set up with the various support conditions. Mounts are provided in the top supports to hold the weights.

Load is gradually applied to the test bars in small increments. This enables the sudden loss of stability – the buckling – to be clearly shown.

The various elements of the experiment are clearly laid-out and housed securely in a storage system.

Learning objectives/experiments

- demonstration of various buckling problems
 - ▶ Euler case 1 – fixed-free bar
 - ▶ Euler case 2 – pinned-pinned bar
 - ▶ Euler case 3 – fixed-pinned bar
 - ▶ Euler case 4 – fixed-fixed bar
- familiarisation with the correlation between buckling length, buckling load and various methods of support

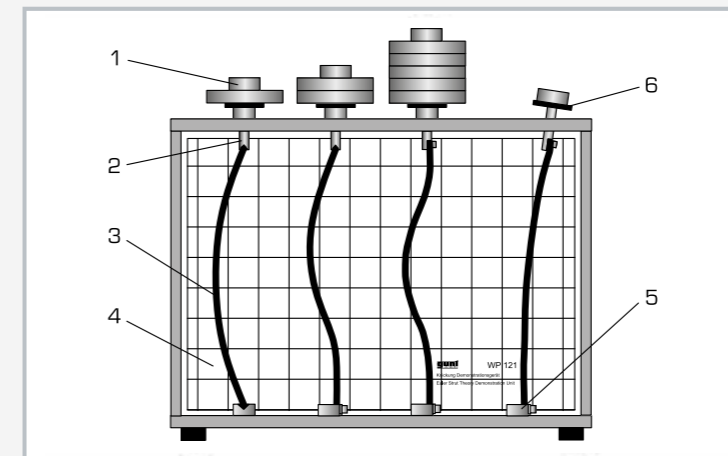

1 weight, 2 pinned support, 3 bar, 4 backing wall with grid pattern, 5 fixed support, 6 mount for weight

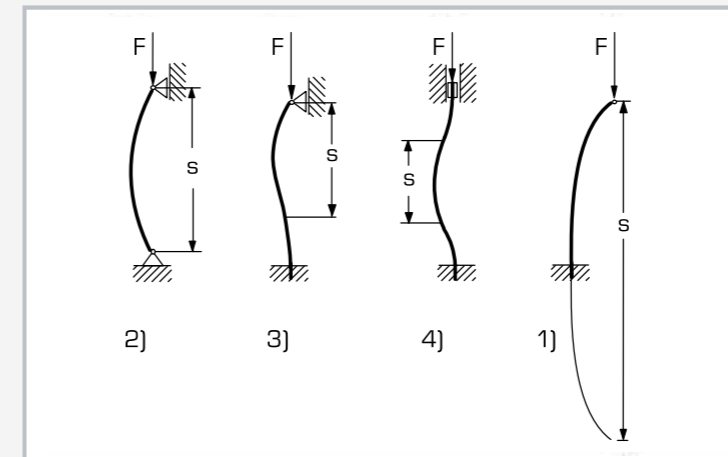

Buckling length dependent on end conditions of bars:

- 1) Euler case 1: fixed-free bar
 - 2) Euler case 2: pinned-pinned bar
 - 3) Euler case 3: fixed-pinned bar (pinned at the top)
 - 4) Euler case 4: fixed-fixed bar;
- F applied buckling load, s buckling length



storage system

Specification

- [1] demonstration of elastic buckling
- [2] representation of 4 cases of Euler buckling
- [3] 4 steel test bars
- [4] test bar ends pinned or fixed
- [5] test bars cannot be overloaded
- [6] white backing wall with grid patterning
- [7] storage system to house the components

Technical data

Test bars

- quantity: 4
- bar length: 180mm
- bar cross-section: 0,5x12mm
- material: steel 1.4310 cold-worked
- buckling loads: approx. 2...32N

Weights

- 10x 5N
- 5x 1N

LxWxH: 380x110x270mm

Weight: approx. 10kg

LxWxH: 720x480x178mm [storage system]

Weight: approx. 10kg [storage system]

Scope of delivery

- 1 experimental unit
- 1 set of specimens
- 1 set of weights
- 1 storage system with foam inlay
- 1 set of instructional material

WP 120

Buckling behaviour of bars



Learning objectives/experiments

- investigation of buckling behaviour under the influence of
 - ▶ different supports and clamps
 - ▶ different bar lengths and cross-sections
 - ▶ different materials
 - ▶ additional lateral load
- testing Euler's theory: buckling on elastic bars
- calculating the expected buckling force with Euler's formula
- graphical analysis of the deflection and the force
- determine elastic modulus for an unknown material (GFRP)
- measure force and deflection
- with the WP 120.01 expansion set investigation of buckling behaviour under the influence of
 - ▶ different cross-section shapes
 - ▶ eccentric application of force

Description

- investigation of all relevant buckling problems
- verification of Euler's theory of buckling
- experiments with eccentric application of force and lateral load

In engineering mechanics, loss of stability is known as buckling. The bar axis laterally deflects under the effect of compressive forces and with increasing load until it suddenly and violently fails, just before the fracture strength is reached. The stresses in the bar are often still in the elastic region.

WP 120 investigates the buckling behaviour of bars under different influences. All relevant buckling problems are demonstrated in experiments.

In this experiment, a bar is clamped or supported at both ends in the experimental unit, depending on the buckling case. A height-adjustable loading member and a hand-operated spindle are used to apply a compressive force to the bar. An axial support between the spindle and bar support prevents torsional stress on the test bar. The applied force is hydraulically measured and displayed on a force gauge. A dial gauge indicates the lateral deflection of the bar.

Experiments demonstrate how various factors such as bar length, material and support type affect the buckling behaviour. Additional shear forces can be generated on the test bar by means of a lateral load mechanism.

The experiments can be conducted in a vertical or horizontal position; the force gauge can be rotated by 90°.

An expansion set with sample bars expands the scope of experiments that can be conducted with WP 120. The parts of the experiment are clearly laid out and securely housed in a storage system.

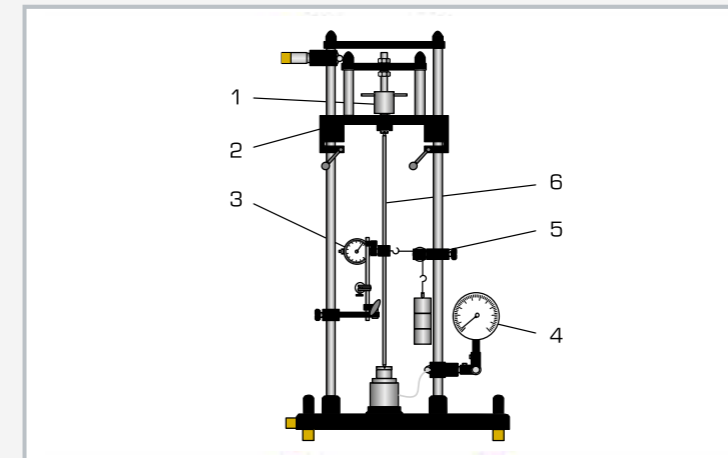

1 spindle, 2 height-adjustable load member, 3 dial gauge for lateral deflection of the test bar, 4 dynamometer, 5 mechanism for generating a lateral load, 6 test bar

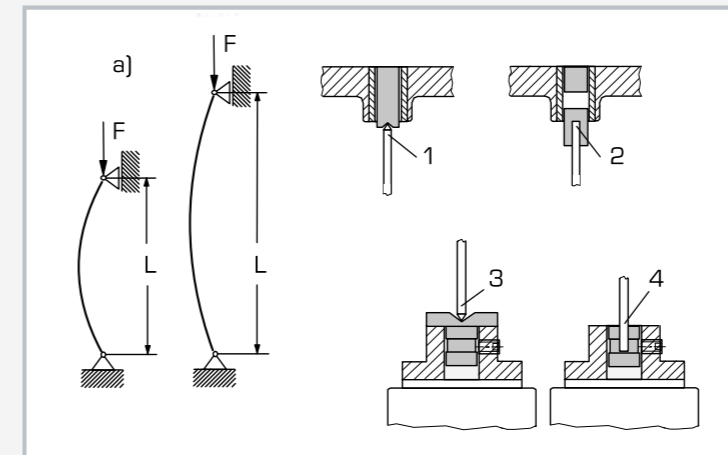

a) experiment on how bar length affects the buckling behaviour: F applied force, L bar length; 1 top movable support, 2 top clamp, 3 bottom movable support, 4 bottom clamp

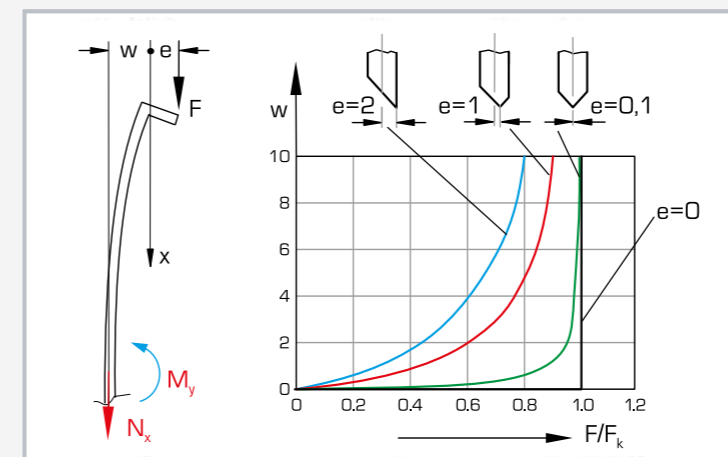

Experiment with eccentric application of force (WP 120.01): F applied force, e eccentricity, w deflection, M_y bending moment, F/F_k compressive force based on critical compressive force; diagram: deflection of the test bar for varying eccentricity

Specification

- [1] investigation of all relevant buckling cases
- [2] verification of Euler's theory of buckling
- [3] experiments in the horizontal or vertical position
- [4] test bars with different lengths made of different materials
- [5] test bars pinned or fixed
- [6] spindle for applying forces
- [7] lateral load mechanism generates shear forces
- [8] force measurement using a hydraulic dynamometer
- [9] measurement of lateral deflection with a dial gauge
- [10] further experiments with WP 120.01 expansion set
- [11] storage system for parts

Technical data

Test bars

- quantity: 11
- bar lengths: 350...700mm (max.)
- materials: aluminium, copper, brass, steel, GFRP
- cross-sections: 10x4mm, 25x6mm, 25x10mm

Load spindle

- force: max. 2000N
- stroke: max. 10mm
- Lateral deflection: max. 20mm
- Sample holder hole diameter: \varnothing 20mm

Weight for lateral load: max. 20N

- 1x 5N (hanger), 3x 5N

Measuring ranges

- force: 0...2500N, graduation: 50N
- deflection: 0...20mm, graduation: 0,01mm

LxWxH: 620x450x1150mm

Weight: approx. 63kg

LxWxH: 1170x480x178mm (storage system)





Weight: approx. 12kg (storage system)

Scope of delivery



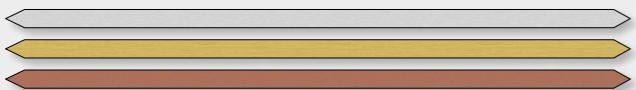



- 1 experimental unit
- 1 set of specimens
- 1 set of measuring instruments
- 1 storage system with foam inlay
- 1 set of instructional material

Accessories for WP 120

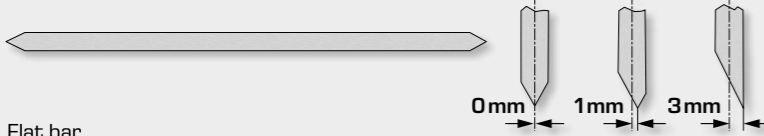
WP 120 contains the following test bars:

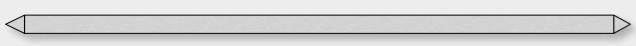
 Flat bar	Pinned end / pinned end Cross-section: 20x4 mm Bar length in mm: 350, 500, 600, 650, 700 Material: St
 Flat bar	Pinned end / pinned end Cross-section: 25x6 mm Bar length: 600 mm Material: Al, CuZn, Cu
 Flat bar	Pinned end / pinned end Cross-section: 25x10 mm, bar length: 600 mm Material: GRP
 Flat bar	Pinned end / fixed end Cross-section: 20x4 mm, bar length: 650 mm Material: St
 Flat bar	Fixed end / fixed end Cross-section: 20x4 mm, bar length: 650 mm Material: St

WP 120.01 supplementary set contains the following test bars:

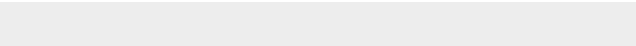
 Flat bar	Pinned end / pinned end Cross-section: 25x6 mm Bar length: 500 mm Eccentricity: 0 mm, 1 mm, 3 mm Material: Al
 Flat bar	Pinned end / pinned end Cross-section: 40x6 mm, bar length: 500 mm Material: Al
 Square tube	Pinned end / pinned end Cross-section: 20x10x2 mm, bar length: 700 mm Material: Al
 Flat bar	Pinned end / pinned end Cross-section: 25x10 mm, bar length: 700 mm Material: GRP
 Round tube	Pinned end / pinned end Cross-section: D = 15x2 mm, bar length: 700 mm Material: Al
 Round bar	Pinned end / pinned end Cross-section: D = 14 mm, bar length: 700 mm Material: Al
 Round tube	Pinned end / pinned end Cross-section: D = 16x2 mm, D = 20x1,5 mm Bar length: 700 mm Material: PVC

GUNT storage systems keep your lab tidy!

WP 121

Demonstration of Euler buckling



WP 950

Deformation of straight beams



WP 130

Verification of stress hypotheses



SE 110.19

Investigation of simple stability problems



FL 160

Unsymmetrical bending



Description

- **symmetrical and unsymmetrical bending on a beam**
- **symmetrical and unsymmetrical cross-sectional profiles: I, L and U**
- **combined bending and torsion loading by way of eccentric force application**

Symmetrical bending of a beam – also known as uniaxial bending – occurs when the load plane coincides with one of the main axes of the beam cross-section. The beam then deflects in the direction of the load and can be described by elastic lines.

In unsymmetrical bending of a beam – also known as complex or biaxial bending – the main axes of the cross-section do not coincide with the direction of loading. To prevent torsion, the line of application of the load must pass through the shear centre. If it does not, the beam undergoes combined bending and torsion loading.

FL 160 is used to perform experiments relating to symmetrical and unsymmetrical bending and to combined bending and torsion loading. The beam under investigation is clamped into place on one end and loaded down at the free end. Two dial gauges record the horizontal and vertical deformation of the beam.

The unit includes three beams with different cross-sectional profiles: I, L and U. The beam can be clamped with freedom to rotate in any direction. This enables investigation of loading along the main axis or of the general load case. An angle scale at the clamping point indicates the angular position of the beam. It is possible to adjust the load application point eccentrically, so that purely unsymmetrical bending or combined bending and torsion loading is investigated.

The various elements of the experiment are clearly laid-out and housed securely in a storage system.

Learning objectives/experiments

- product moment of inertia (I_{yz}) and axial second moment of area (I_y, I_z)
- Bernoulli hypothesis
- symmetrical bending on a beam (uniaxial)
 - ▶ with I-profile
 - ▶ with L-profile
 - ▶ with U-profile
- unsymmetrical bending (complex) on a beam with an L-profile
 - ▶ calculation of the neutral fibres
- combined bending and torsion loading by way of eccentric force application
- determination of the shear centre on a beam with a U-profile
 - ▶ familiarisation with shear flow (shear forces in a cross-section)
- comparison of calculated and measured values

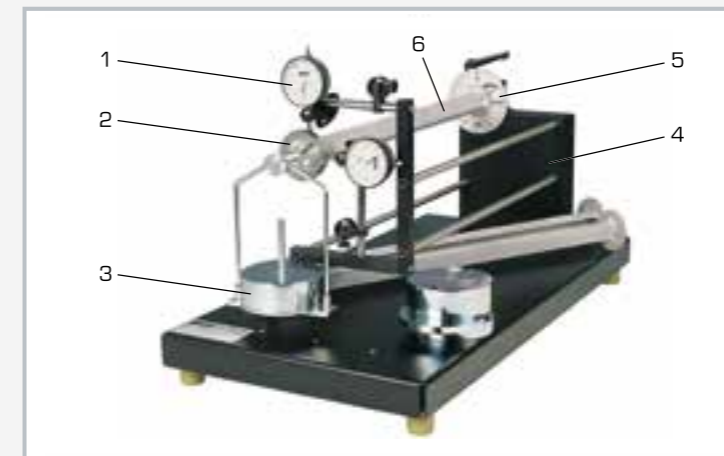

1 dial gauge, 2 device to adjust the eccentricity of the load application point and flange to mount the load, 3 weight, 4 clamping pillar, 5 clamping flange of beam with angle scale, 6 beam

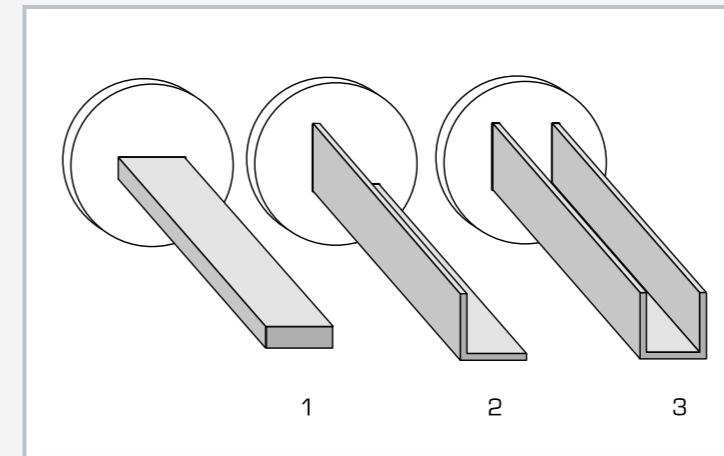

Beam: 1 I-profile, 2 L-profile, 3 U-profile

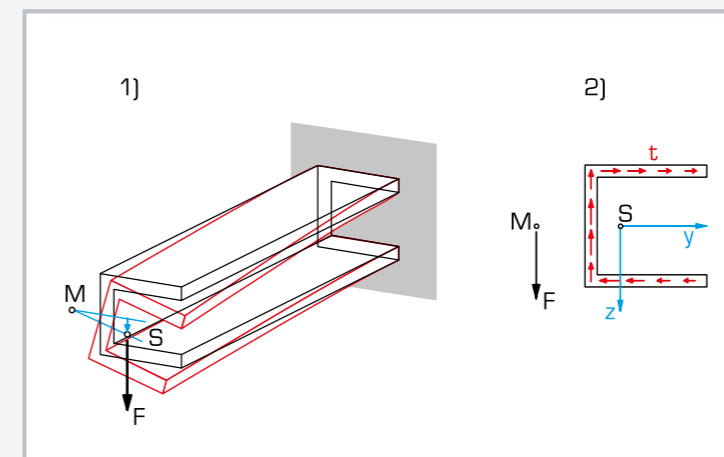

1 on application of the force at the centre of gravity the beam twists, 2 on application of the force at the shear centre no torsion occurs; M shear centre, S centre of gravity, F force, t shear flow

Specification

- [1] experimental unit for general and unsymmetrical bending of straight beams
- [2] 3 beams: I, L and U profiles
- [3] clamping flange of beam can be clamped in the pillar free to rotate in any direction
- [4] clamping flange with angle scale to indicate the angular position of the beam
- [5] eccentricity of load application point adjustable
- [6] 2 dial gauges with bracket to record the horizontal and vertical deformation of the beam under load
- [7] storage system to house the components

Technical data

Aluminium beam
 ■ deformed length: 500mm

Eccentricity of load application point: 0...25mm

Dial gauges
 ■ 0...10mm, graduation: 0,01mm

Angle scale
 ■ 0...360°, graduation: 1°

Weights
 ■ 1x 2,5N (hanger)
 ■ 1x 2,5N
 ■ 3x 5N

LxWxH: 700x350x400mm
 Weight: approx. 25kg
 LxWxH: 720x480x178mm (storage system)

Scope of delivery

- 1 experimental unit
- 3 beams
- 2 dial gauges with bracket
- 1 set of weights
- 1 spirit level
- 1 hexagon socket wrench
- 1 storage system with foam inlay
- 1 set of instructional material

WP 130

Verification of stress hypotheses



Learning objectives/experiments

- generation of multi-axial loads on test samples made of ductile metals:
 - ▶ steel, copper, brass, aluminium
- generation of various load moments
 - ▶ pure bending moment
 - ▶ pure twisting moment
 - ▶ combined bending moment and twisting moment
- determination of the yield point
- verification of the Rankine yield criterion
- verification of the Tresca yield criterion
- representation in Mohr's circle of stresses and strains

Description

- verification of the Rankine yield criterion and the Tresca yield criterion
- multi-axial loads of test specimens made of ductile metals by pure bending, pure torsion or a combination of the two
- loading of the test specimen without shear force by compensation for the influence of dead-load

Stress hypotheses are applied in the science of the strength of materials when calculating comparative stresses where unequal stresses are combined.

The following stress hypotheses, taking into account material properties, have been tried and proven in practice: Rankine yield criterion (direct stress hypothesis), von Mises yield criterion (change of shape hypothesis) and Tresca yield criterion (shear stress hypothesis).

The experimental unit WP 130 is used to verify these comparative stress hypotheses on test specimens made of various metals. For the purpose, a multi-axial stress state is produced at a point on the specimen and the resulting deformation is measured.

The specimen is clamped on one end to the fixed frame. A loading plate is clamped to the specimen on the other end. A weight is attached on the outer circumference of the plate. A balance weight compensates for the dead-load of the plate and the applied weight. As a result only direct and shearing stress occur at a point on the test specimen and shear forces are avoided.

The loading plate has a graduation grid enabling weights to be attached at 15° increments. This permits purely bending moment and twisting as well as combined load moments to be achieved. Diametrically opposite the weight, measuring points are provided on the loading plate to measure the deformation. This enables the deformation at the point of maximum deflection to be measured.

The various elements of the experiment are clearly laid-out and housed securely in a storage system.

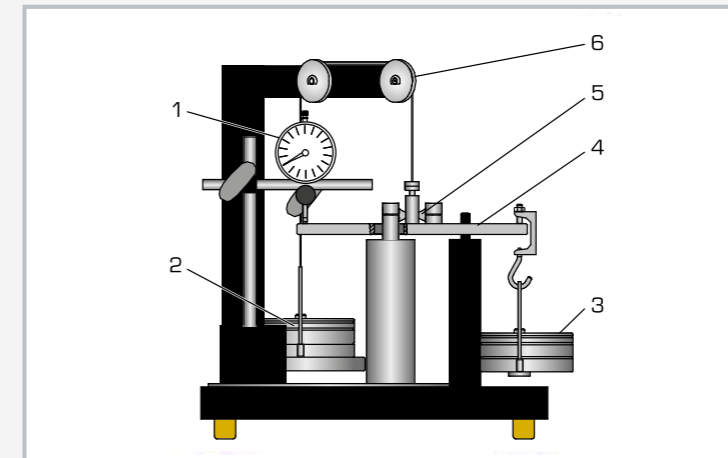

1 dial gauge, 2 balance weight, 3 weight, 4 loading plate, 5 test specimen in clamps, 6 deflection roller and cable to compensate for the dead-load of the plate

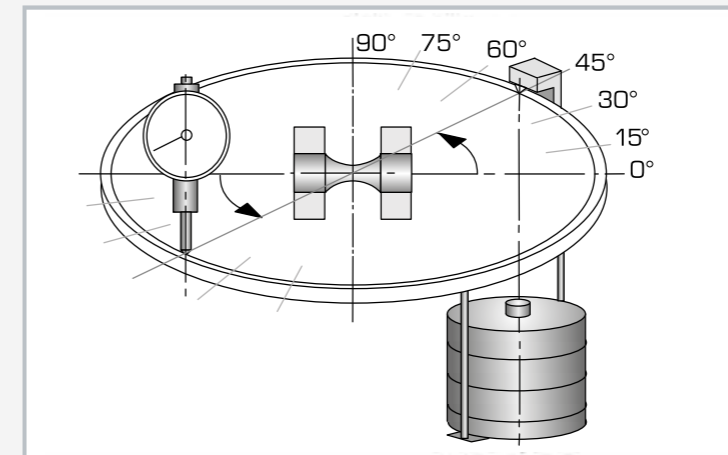

Clamped specimen: 0° = pure bending, 90° = pure torsion, all angle settings between = combined loading

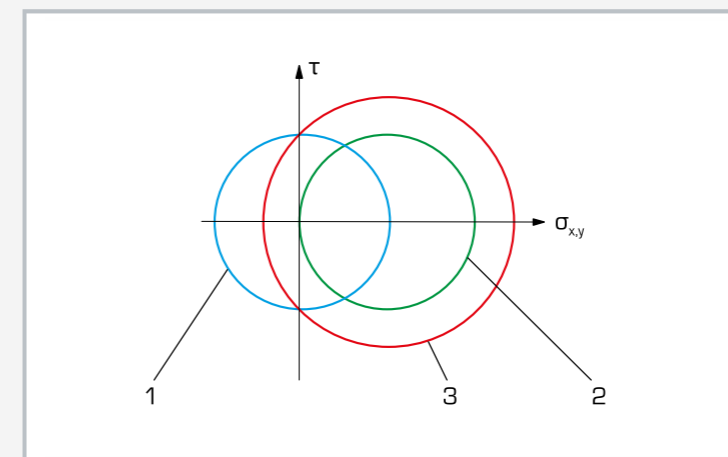

Mohr's circles for combined loading: bending with simultaneous torsion; 1 pure torsion, pure bending, 3 bending and torsion together; σ direct stresses, τ shear stresses

Specification

- [1] experiments verifying comparative stress hypotheses from the science of the strength of materials
- [2] 7 different load combinations of bending and torsion
- [3] loading of the test specimen without shear force by compensation for the influence of dead-load
- [4] test specimens made of steel, copper, brass, aluminium
- [5] generation of load moments by means of weight and lever arm
- [6] measurement of the deformation at the point of maximum deflection
- [7] storage system to house the components

Technical data

Specimens

- length: 49mm
- clamping length: 11,5mm
- specimen diameter in measuring cross-section: \varnothing 4mm

Weights to place load on specimens

- 1x 2N (hanger), 1x 1N, 1x 2N, 1x 4N, 2x 8N

Weights to compensate for the load and the loading plate

- 1x1N, 2x2N, 1x4N, 2x8N

Lever arm: 100mm

Deformation

- measuring range: 0...10mm
- graduation: 0,01mm

LxWxH: 390x330x360mm

Weight: approx. 17kg

LxWxH: 720x480x178mm (storage system)

Weight: approx. 10kg (storage system)

Scope of delivery

- 1 experimental unit
- 1 set of specimens (4x St, 4x Cu, 4x Al, 4x brass)
- 1 set of weights (loading)
- 1 set of weights (compensation)
- 1 hexagon socket wrench
- 1 storage system with foam inlay
- 1 set of instructional material

Experimental stress and strain analysis

When dimensioning components are subject to mechanical load so that they can properly perform their function, it is necessary to know the nature of the loads. In particular, it is important to determine the maximum occurring stresses, which ultimately define the dimensions. These stresses should be determined in advance and then tested by experiment. Experimental stress and strain analysis can therefore be regarded as a link between theoretical calculation and experimental evidence.

Two methods of non-destructive experimental stress and strain analysis are presented here:

- the **electrical method** of strain measurement using strain gauges to indirectly determine the actual stresses
- the **photoelastic method** for a direct representation of the stress distribution

Strain measurement using strain gauges

Stresses in components can be determined via the circuitous route of strain measurement, as the strain of the material is directly related to the material stress. An important branch of experimental stress and strain analysis is based on the principle of strain measurement. The advantage of this method is that strain gauges can be used on real components in operation.

Strain gauges comprise resistance wires that are adhered to the surface of the workpiece. If the surface is extended, the wire is lengthened and its cross-section decreases. This increases the electrical resistance. In the case of compression, the resistance decreases. In a Wheatstone bridge, the resistors are connected as a voltage divider. The measuring circuit is particularly suited for measuring small changes in resistance and, therefore, for determining the resistance change of a strain gauge.

Determining the magnitude and direction of mechanical stresses

Using the generalised Hooke's law, we can calculate the stresses σ from the strain ϵ measured at the surface.

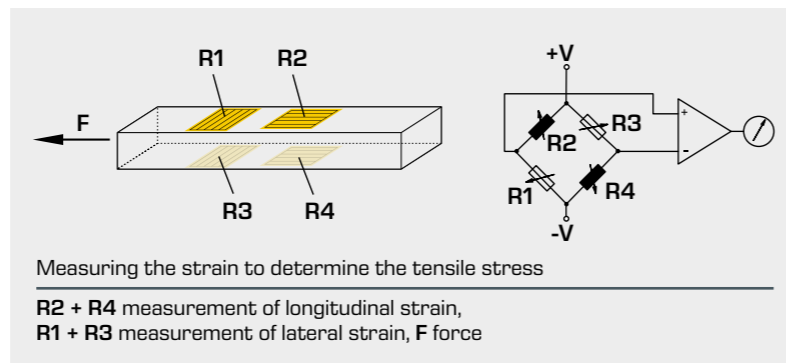

Selecting and installing the strain gauge to investigate different stress states

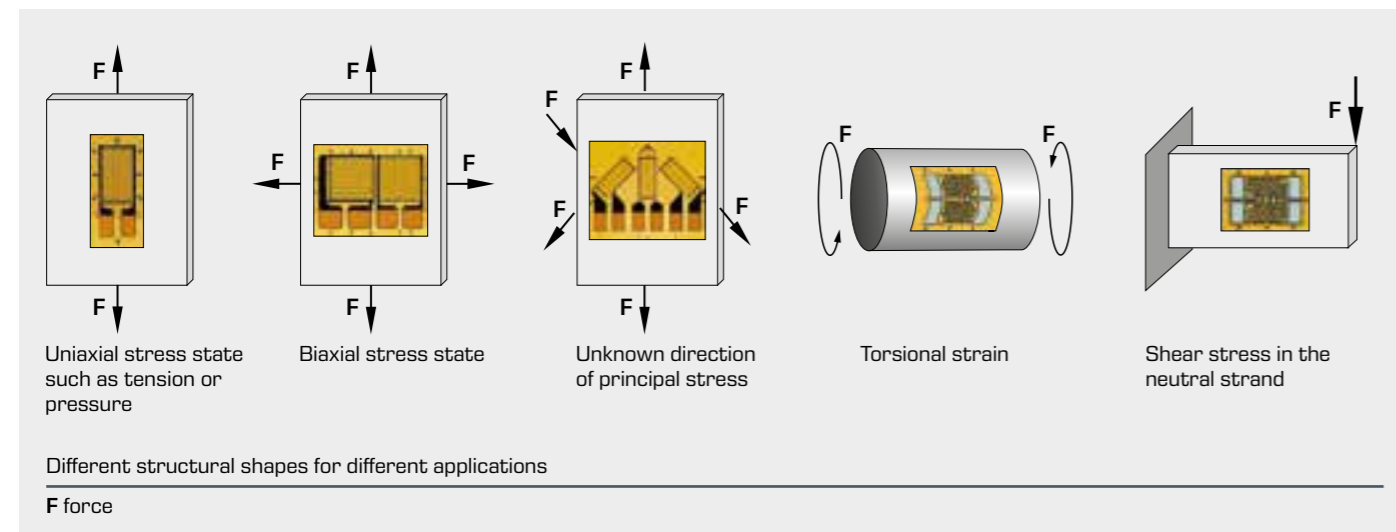

Representation of the stress distribution using photoelasticity

Photoelasticity is a method with great illustrative qualities and a simple experimental setup, in which two-dimensional stresses in the model of a component are made visible. Polarised light shines through the model – which is made of a special transparent plastic – and it is subjected to mechanical load. The load causes stresses in the model. This causes birefringence in the plastic in the direction of the principal stresses. Stresses can be made visible in the model using a polarisation filter (analyser). Photoelasticity, therefore, provides a complete picture of the stress field and offers a good overview of areas of high stress concentration and areas of low stress. Consequently, analyt-

ically or numerically performed stress considerations can be visually verified.

The relevant effect is attributed to the birefringence of transparent materials under mechanical load and light exposure. In plastics, birefringence occurs in the direction of the principal stresses. These physical properties are used in photoelasticity to make visible stresses or the resulting strains. This is why plastic models are used in these experiments instead of the original materials.

Principle of photoelasticity

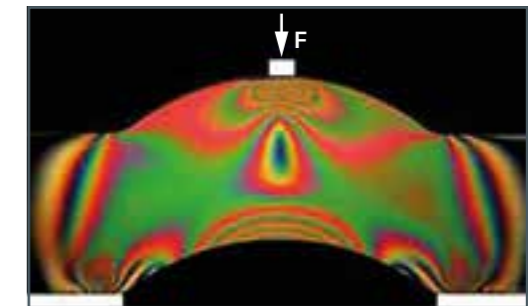
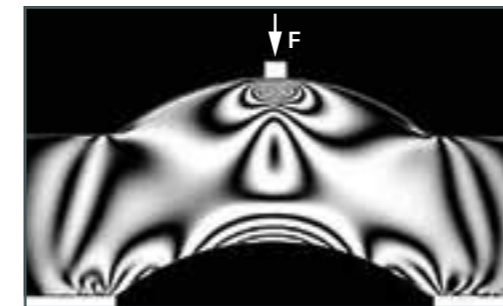
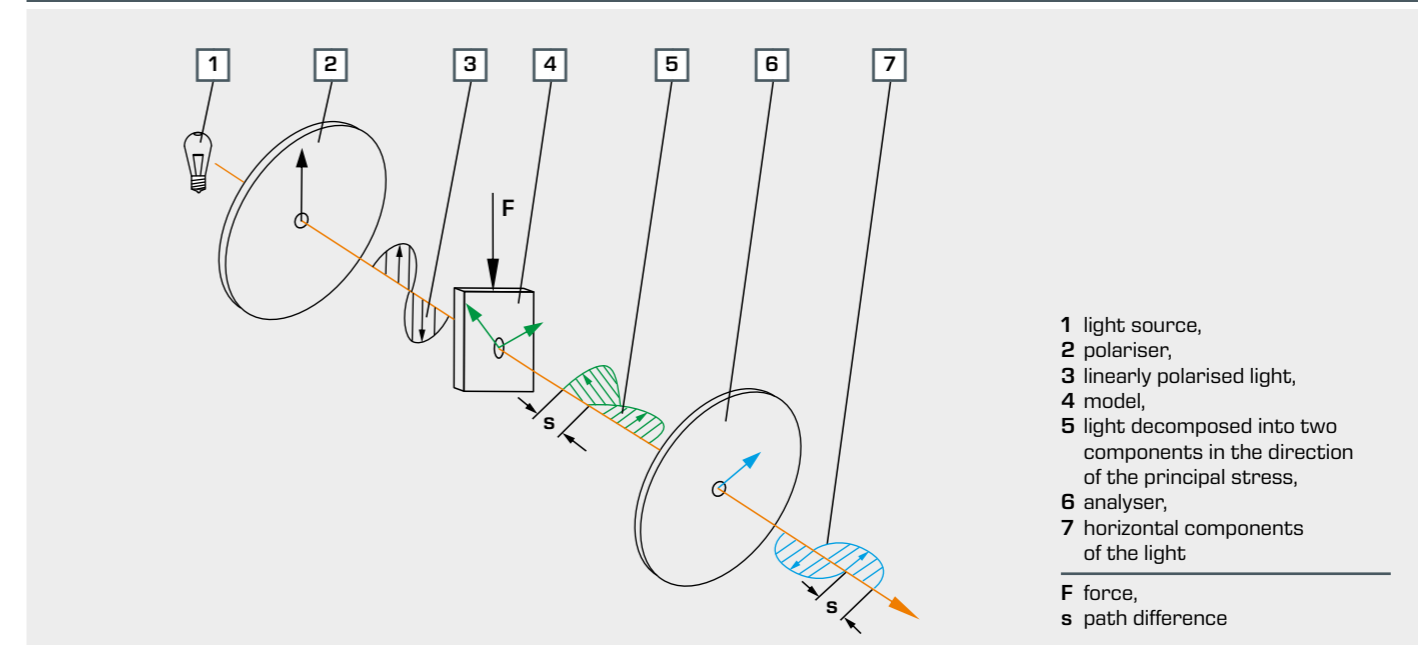

A polariscope can be used to study transparent models of components, whose optical properties change under the influence of internal stresses. If the model is stress-free, there is no birefringence and the model appears black. If a load is applied and increased, this creates a path difference that increases in proportion to the magnitude of the difference in the principal stresses.

The arch shown here is loaded by the force F like a vault. The high density of isochromats in the inner circle of the arch – where the highest stresses occur – can be clearly seen. The individual lines are better resolved in monochromatic light, and in the above illustration, we can clearly recognise the onion-like linear paths under the application of force.

FL 101

Strain gauge application set



Learning objectives/experiments

- fundamentals of electrical resistance strain gauges
- preparation of the measuring point
- selection of a suitable strain gauge
- attaching, wiring up and configuring strain gauges on mechanically stressed components
- protection of the strain gauge measuring point against external influences
- interpretation of measured values (theoretical)

Description

- complete equipment for application of strain gauges with wiring and connecting of strain gauges
- supporting the development of strain gauge measuring techniques

Measurement using strain gauges is the most important method of measuring mechanical strain. In this measuring method mechanical quantities are measured electrically.

Strain gauge measurement is a relatively simple technique in practice, as it offers a high resolution and can be employed directly at the point of interest. A strain gauge is not a complete measuring instrument however. It is only rendered usable by the user, after being installed. The quality of measurement depends not only on the strain gauge itself, but also essentially on the

application method and how it is executed. Strain gauges are highly reliable provided users have the skills and theoretical knowledge enabling them to use such highly sensitive sensor elements correctly.

The application set FL 101 provides all the necessary tools and aids to learn the fundamentals of strain gauges installation.

For the measurements to work without error, components are first subjected to thorough preparation before the strain gauges are attached. Special adhesives ensure total transfer of component deformations to the strain gauge. The strain gauge is also protected by suitable coverings against external influences, such as damp and mechanical damage, by suitable coverings.

The supplied package includes wiring to connect the strain gauges in bridge configurations. The wires are attached to the strain gauges using a supplied soldering bit and soldering terminals.

The instructional material (text book, exercise script and video) provides a multimedia introduction to the installation and configuration of strain gauges and on interpretation of measured values.

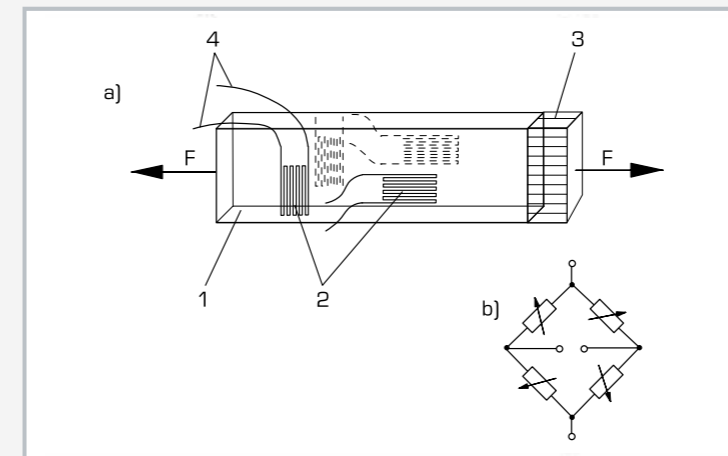

a) arrangement of strain gauges on tension bar; b) configuration of strain gauges; 1 tension bar, 2 strain gauge, 3 distribution of stress, 4 wiring; F applied force

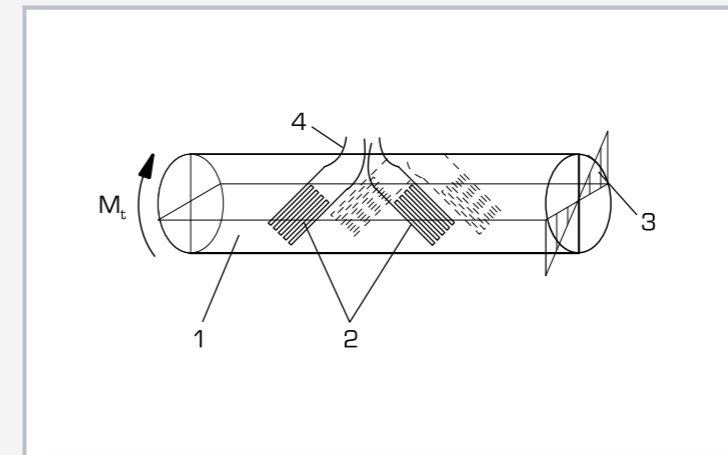

Arrangement of strain gauges on torsion bar: 1 round bar, 2 strain gauge, 3 distribution of stress, 4 wiring; M_t torque

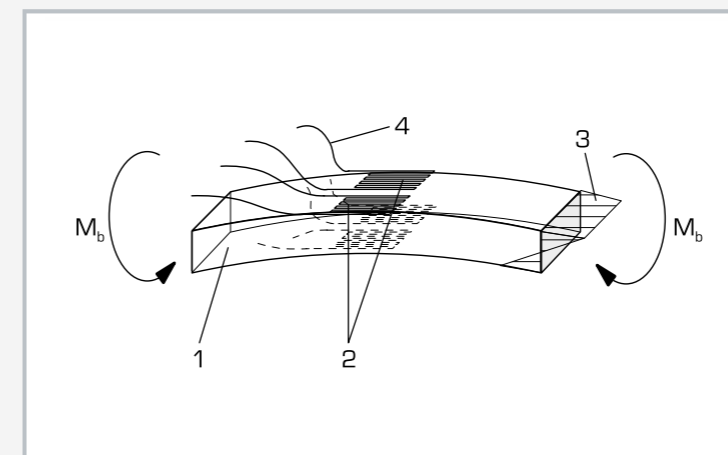

Arrangement of strain gauges on bending bar: 1 bar, 2 strain gauge, 3 distribution of stress, 4 wiring; M_b bending moment

Specification

- [1] complete set of components for application of strain gauges
- [2] strain gauges with single measuring grids, parallel measuring grids and measuring grids at $90^\circ / 45^\circ$ angles
- [3] strain gauges for steel or aluminium components
- [4] all necessary tools, adhesives and other aids included in the set
- [5] lockable carrying case
- [6] learning package with text book, exercise script and video
- [7] cable and connectors to connect the applied strain gauges to the optional available measuring amplifier FL 151

Technical data

Strain gauge: 350 Ohm

- 10 strain gauges, single measuring grids, for St
- 10 strain gauges, parallel measuring grids, for St
- 10 strain gauges, 90° measuring grids, for St
- 10 strain gauges, 45° measuring grids, for St
- 10 strain gauges, single measuring grids, for Al

Soldering bit: 16W

Ribbon cable: $6 \times 0,14 \text{ mm}^2$

Magnifying glass: 6-times magnification

230V, 50Hz, 1 phase

230V, 60Hz, 1 phase; 120V, 60Hz, 1 phase

UL/CSA optional

LxWxH: $470 \times 360 \times 170 \text{ mm}$

Weight: approx. 8kg

Scope of delivery

- 1 carrying case
- 1 set of strain gauges
- 1 application set complete (solvent, cleaning agent, special strain gauge adhesive, adhesive strips, coverings)
- 1 set of pincers
- 2 scissors
- 1 set of application tools
- 1 set of cutting tools
- 1 soldering bit, soldering terminals
- 1 set of accessories (measuring tools, magnifying glass, cable, abrasive cloth, pencil, rubber eraser)
- 1 strain gauge learning package (text book, exercise script, video) in German or English
- 8 6-pole connectors for connection to FL 151
- 5m cable for connection to FL 151

FL 100

Strain gauge training system



Description

- basic introduction to measurement with strain gauges
- test bars for tension, bending and torsion with strain gauge measuring points as full bridge
- universal 1-channel measuring amplifier

Strain gauges are used extensively in sensor systems to detect forces, moments and deformations.

The FL 100 experimental unit provides a wide-ranging introduction to the fundamentals of measurement by strain gauges. Three test specimens for tension, bending and torsion are each fitted with four strain gauge measuring points. The strain gauges are wired in the full bridge. The specimens are loaded incrementally allowing for the strain reading to be sequentially monitored.

The specimens can be inserted quickly and precisely into the frame. The strain gauge measuring range is protected by a Plexiglas cover, which also makes it clearly visible for inspection purposes. The measuring amplifier supplies the bridge supply voltage, and displays the load-dependent "bridge detuning" digitally in voltage values. The digital display also features a zero balancing function to allow for any preloading.

The various elements of the experiment are clearly laid-out and housed securely in a storage system.

Three additional tension bars are available as accessories, in brass (FL 100.01), copper (FL 100.02) and aluminium (FL 100.03), enabling the modulus of elasticity to be ascertained in experiments.

Learning objectives/experiments

- fundamentals of measuring with strain gauges
- strain gauge types and application techniques
- calculation of the mechanical deformations under tension, bending and torsion
- correlation between mechanical strain and electrical resistance in a strain gauge
- with FL 100.01, FL 100.02, FL 100.03: determination of the modulus of elasticity for various materials from the measuring data of a tensile test

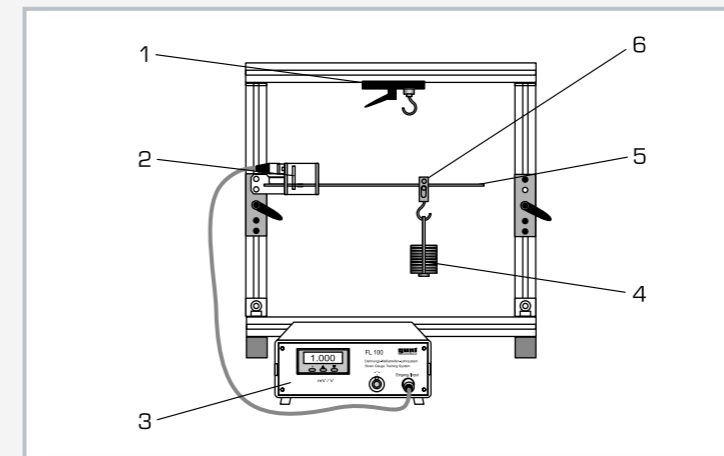

1 fixture, 2 strain gauge measuring point, 3 measuring amplifier, 4 weight, 5 bending bar, 6 adjustable rider

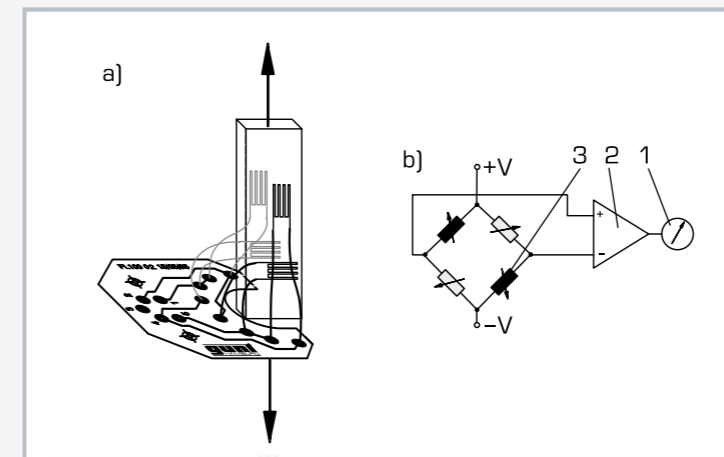

a) strain gauge arrangement on the tension bar (full bridge),
b) full bridge circuit: 1 display, 2 amplifier, 3 active strain gauge

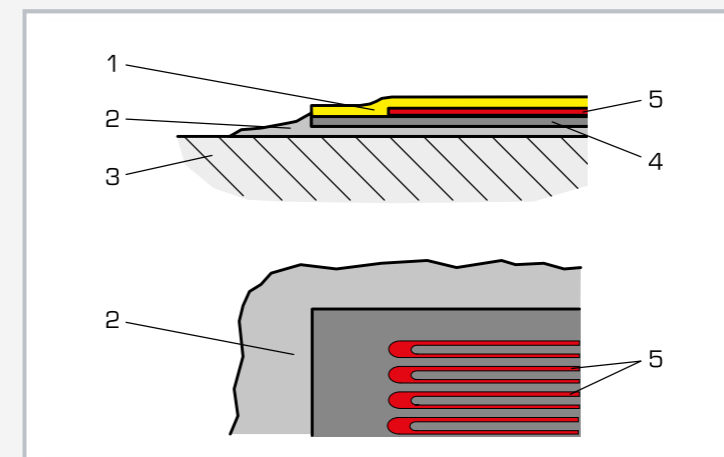

Layout of a strain gauge measuring point: 1 cover sheet, 2 adhesive, 3 component, 4 substrat, 5 gauge measuring grid

Specification

- [1] experimental unit investigating the fundamentals of strain gauge measurement
- [2] tension, bending and torsion tests each with strain gauge measuring points in full bridge circuit
- [3] strain gauge application areas protected by Plexiglas cover
- [4] steel test bodies
- [5] measuring amplifier with 4-digit digital display
- [6] frame to house the measuring objects
- [7] determination of modulus of elasticity on various materials using measuring objects FL 100.01, FL 100.02, FL 100.03
- [8] storage system to house the components

Technical data

Tension bar

- measuring length: 50mm
- cross-section: $2 \times 10 \text{ mm}^2$
- modulus of elasticity: 191000 N/mm^2
- Poisson's ratio: 0,305

Bending bar

- length: 385mm
- cross-section: $5 \times 20 \text{ mm}^2$
- modulus of elasticity: 210000 N/mm^2
- section modulus: $74,26 \text{ mm}^3$

Torsion bar

- length: 500mm, $\varnothing = 10 \text{ mm}$
- section modulus: $196,3 \text{ mm}^3$
- shear modulus: 80000 N/mm^2

Weights

- small: 10x 0,5N, 1x 1N (hanger)
- large: 1x 5N, 2x 10N, 1x 20N, 1x 5N (hanger)

Strain gauge measuring point: full bridge, 350Ω

Amplifier

- measuring range: $\pm 24 \text{ mV}$
- resolution: $1 \mu \text{ V}$
- zero balancing adjustment range: $\pm 1 \text{ mV}$
- supply voltage: 10VDC

Frame opening WxH: 480x450mm

230V, 50Hz, 1 phase
230V, 60Hz, 1 phase; 120V, 60Hz, 1 phase
UL/CSA optional
LxWxH: 560x410x610mm (frame)
LxWxH: 600x400x320mm (storage system)
Weight: approx. 20kg

Scope of delivery

- 1 frame
- 3 strain gauge test specimens
- 2 sets of weights
- 2 hexagon socket wrenches
- 1 measuring amplifier with strain gauge connecting cable
- 1 storage system with foam inlay
- 1 set of instructional material

FL 102**Determining the gauge factor of strain gauges****Description**
■ measurement of deflection and strain
■ determination of the gauge factor of strain gauges

As universal aids to experimental stress and strain analysis, strain gauges enable mechanical strain to be converted into electrical signals. The signal obtained is processed by a strain measuring amplifier to give a display of the resulting strain.

It is expected that the quantity measured by a measuring device and the readout subsequently indicated are identical. Consequently, the planning and evaluation of measurements makes allowance for the sensitivity to elongation (gauge factor) of strain gauges. A key characteristic value of strain gauges – the gauge factor – indicates the correlation between the strain and the change in resistance.

The FL 102 experimental unit is used to measure deformation by means of a dial gauge and at the same time to measure strain by means of four strain gauges in full bridge configuration. The gauge factor of the strain gauges is then calculated arithmetically from the measurements.

In the experiment, a bar is mounted on ball bearings at two points, thereby permitting purely bending stress to be applied. The bar is placed under load by means of a spindle and the resulting deflection is recorded by a dial gauge. As a result, the deformation can be read-off directly. At the same time the strain on the surface of the bar is recorded by two strain gauges on the compression side and two on the tension side. The strain gauges are wired in the full bridge. The measuring amplifier supplies the bridge supply voltage, and displays the load-dependent "bridge detuning" digitally in voltage values. The digital display also features a zero balancing function to allow for any preloading.

The unknown gauge factor, as a key characteristic, can then be calculated from the deflection ascertained by the strain gauge measurements.

Practical fundamentals, such as gauge application and configuration to form a measuring bridge, can be easily integrated into the overall teaching concept.

Learning objectives/experiments

- fundamentals of measurement using strain gauges
- measurement of deflection using a dial gauge
- determination of the gauge factor of strain gauges

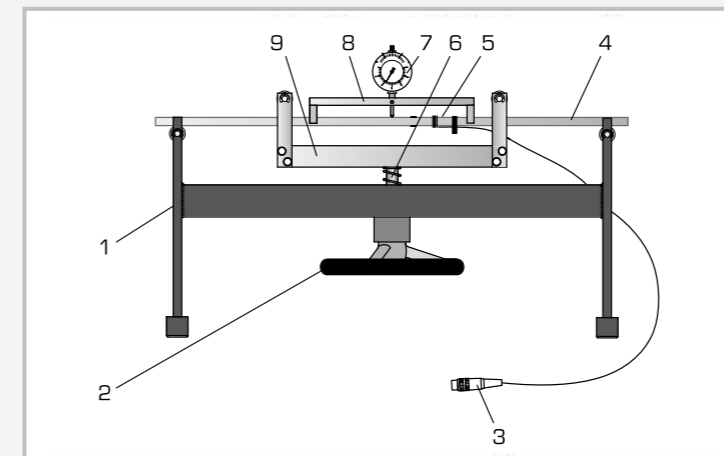

1 base frame, 2 handwheel, 3 connection to measuring amplifier, 4 bending bar, 5 strain gauge measuring point, 6 spindle, 7 dial gauge, 8 fixture for dial gauge, 9 cross-arm

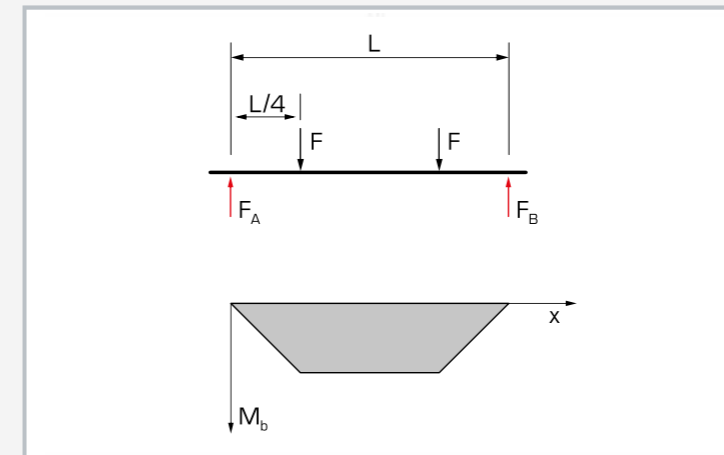

Force and bending moment characteristic on the bending bar:
black: applied force, red: support reactions

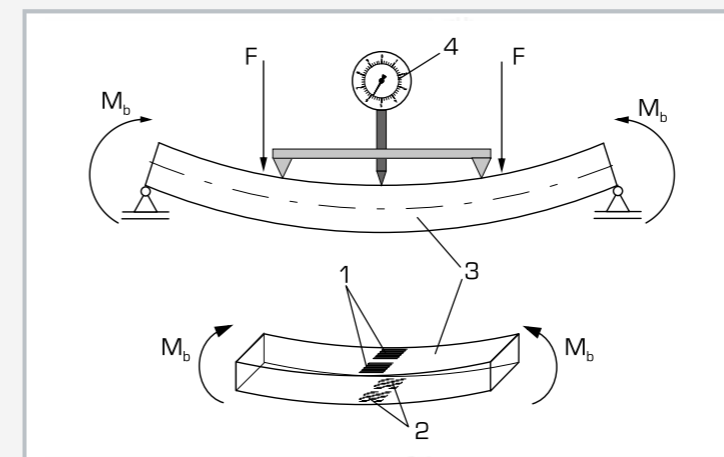

1 strain gauge on top of bar (compression side), 2 strain gauge on underside of bar (tension side), 3 bending bar, 4 dial gauge; M_b bending moment, F applied force

Specification

- [1] investigation of deflection and strain to determine gauge factor
- [2] bending bar with 2 strain gauges on the compression side and tension side respectively
- [3] strain gauge configured as full bridge
- [4] 2-point ball bearing mounting of bar permits purely bending load application
- [5] mechanical load application device with spindle, handwheel and cross-arm
- [6] dial gauge with adjustable dial for direct measurement of deflection
- [7] measuring amplifier with 4-digit digital display

Technical data

Bending bar made of steel: 660x25x12mm

Strain gauge application

- full bridge, 350 Ohm
- 2 strain gauges on the top and underside of the bar respectively

Amplifier

- measuring range: $\pm 2\text{mV/V}$
- resolution: $1\mu\text{V/V}$
- zero balancing adjustment range: $\pm 1\text{mV}$
- supply voltage: 10VDC

Dial gauge

- 0...20mm
- graduation: 0,01mm

230V, 50Hz, 1 phase

230V, 60Hz, 1 phase, 120V, 60Hz, 1 phase

UL/CSA optional

LxWxH: 660x200x430mm

Weight: approx. 20kg

Scope of delivery

- 1 experimental unit
- 1 measuring amplifier
- 1 set of accessories
- 1 set of instructional material

FL 152 PC-based recording and analysis of strain gauge signals

SE 110.21

Forces in various single plane trusses

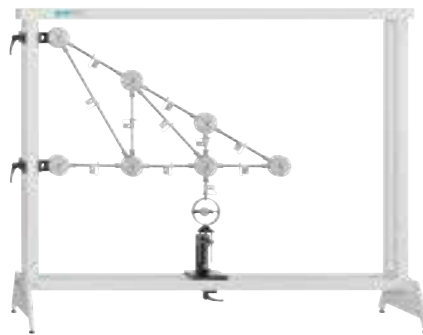

Page 38

FL 120

Stress and strain analysis on a membrane



Page 130

SE 110.22

Forces in an overdeterminate truss

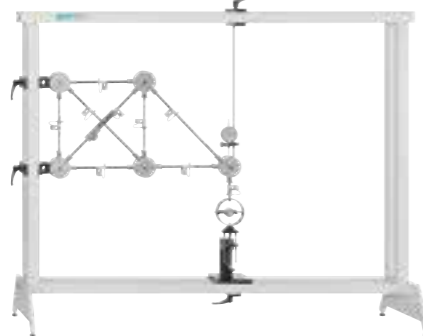

Page 40

FL 130

Stress and strain analysis on a thin-walled cylinder



Page 132

SE 130

Forces in a Howe truss



Page 42

FL 140

Stress and strain analysis on a thick-walled cylinder



Page 134

Whenever our experimental units are used to record forces or stresses using a strain gauge, the FL 152 unit amplifies the measuring signals. These signals are processed further and analysed using the GUNT software.

The unit has 16 input channels for processing analogue strain-gauge measuring signals.

FL 152 is used as either a stand-alone unit or connected to a PC via a USB interface.

The GUNT software supports the topics of stress analysis and truss analysis in a format prepared for teaching.

- touchscreen operation
- the measured values are displayed on the unit or on a PC

GUNT software in FL 152 for conducting and analysing experiments on stress analysis

- read measured values and save to a file
- plot stress and strain curves
- calculate principal strains and principal stresses
- experiment analysis using Mohr's strain circle
- Windows system requirements

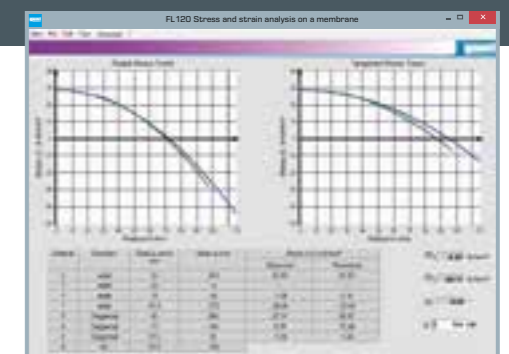

GUNT software in FL 152 for conducting and analysing experiments on truss analysis

- support for conducting and analysing experiments
- simulation of trusses
- configurable trusses
- comparison of occurring forces: theory and measurement
- possible to print out worksheets



FL 152

Multi-channel measuring amplifier



Description

- 16 input channels for processing of analogue strain gauge measuring signals, easy connection by multi-pin input port
- integrated software for evaluation of stress and strain analysis experiments (FL 120, FL 130, FL 140) and experiments relating to forces in trusses (SE 130, SE 110.21, SE 110.22)

Stresses and strains occurring in components are determined in experimental stress and strain analysis by measuring strain. In industry, strain is often recorded by strain gauges. Since strain gauges deliver only small analogue measuring signals, the signals must be amplified in measuring amplifiers. Then they are converted into digital pulses and displayed as measured strain. These strains may also be evaluated and processed on computer.

FL 152 is a multi-channel measuring amplifier which supplies the strain gauge bridge circuits with power and processes the received measuring signals. The measuring amplifier includes 16 input channels. The strain gauge measuring points are connected to associated balance potentiometers by a 68-pin multiport.

The multi-channel measuring amplifier is operated via touchscreen or via PC using the supplied software. The measured values can be read and saved on computer (using an application such as MS Excel).

Learning objectives/experiments

- amplification and display of signals from strain gauge measuring points
- processing of measured values on computer
- evaluation of stress and strain analysis experiments, in conjunction with: FL 120, FL 130, FL 140
- evaluation of experiments relating to forces in trusses, in conjunction with: SE 130, SE 110.21, SE 110.22

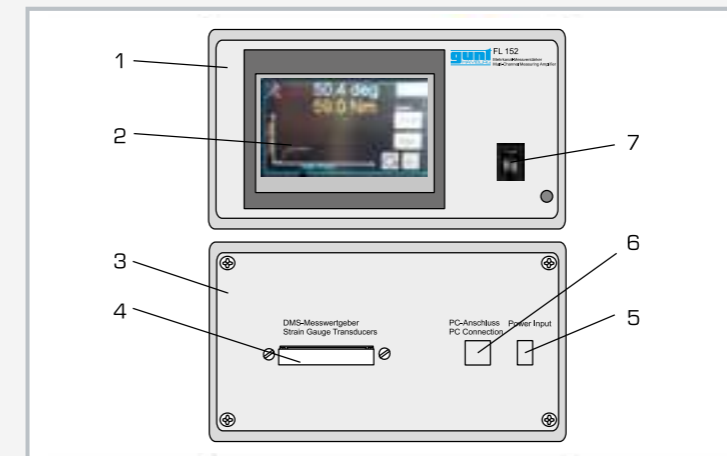

1 front view, 2 touchscreen, 3 rear view, 4 connection of strain gauge measuring points, 5 electric supply, 6 USB interface, 7 main switch



Application software for stress and strain analysis based on the example of the FL 120 (stress and strain analysis on a membrane)



Example application: FL 152 in conjunction with FL 140 (stress and strain analysis on a thick-walled cylinder)

Specification

- [1] multi-channel measuring amplifier for processing of strain gauge signals
- [2] strain gauge connection in half or full bridge configuration
- [3] strain gauge connection via 68-pin input port
- [4] automatic tare of measured values
- [5] processing of measured values directly in the measuring amplifier or using the supplied software on a PC
- [6] integrated software for experimental units on stress and strain analysis [FL 120, FL 130, FL 140] and on forces in trusses [SE 130, SE 110.21, SE 110.22]
- [7] GUNT software for data acquisition via USB under Windows 7, 8.1, 10

Technical data

Amplifier

- number of input channels: 16

Strain gauge connection in half or full bridge configuration

- resistance: min. 350 Ohm/strain gauge
- strain gauge supply voltage: $\pm 5\text{VDC}$

Input voltage: max. $\pm 32\text{mV}$

230V, 50Hz, 1 phase
230V, 60Hz, 1 phase; 120V, 60Hz, 1 phase
UL/CSA optional
LxWxH: 230x200x120mm
Weight: approx. 2kg

Required for operation

PC with Windows recommended

Scope of delivery

- 1 multi-channel measuring amplifier
- 1 GUNT software CD + USB cable
- 1 manual

FL 120

Stress and strain analysis on a membrane



Description

- deflection and strain of a membrane under compressive load
- membrane with strain gauge application
- determine radial and tangential stress profiles from measured strains

In experimental stress and strain analysis, strain gauges are used to determine stresses and strains in components and structures. The maximum stresses and strains are key variables in terms of its structure, and ultimately dictate the dimensions of a component. Strain gauges provide the means required to evaluate mechanical stress and strains.

The FL 120 experimental unit can be used to measure the deflection and strain of a disk under different compressive loads. For this purpose, a thin disk, also called a membrane or diaphragm, is clamped into place and subjected to pressure. A cylinder with a hand-operated piston generates pressure in a maintenance-free hydraulic system. This pressure is indicated on a manometer.

Strains on the surface of the membrane are recorded by strain gauges. The layout of the strain gauges at optimally selected points provides a comprehensive view of the stresses and strains over the entire disk. The maximum stresses and strains are calculated by applying the law of elasticity.

The strain gauge measurements are recorded and displayed by means of the FL 152 measuring amplifier. The measured values can be imported into the application software for visualisation to evaluate the experiment.

At the same time, the deflection of the membrane is measured by a dial gauge. The dial gauge can be moved along a cross-member, enabling measurements to be taken at any radius.

Learning objectives/experiments

- measure radial and tangential strain using strain gauges
- measure deflection using a dial gauge
- calculate the stresses from the measured strains: radial stress, tangential stress
- determine direction of principal stress
- application of Mohr's strain circle to determine the principal strains
- fundamental principle: using strain gauge technology to measure strains

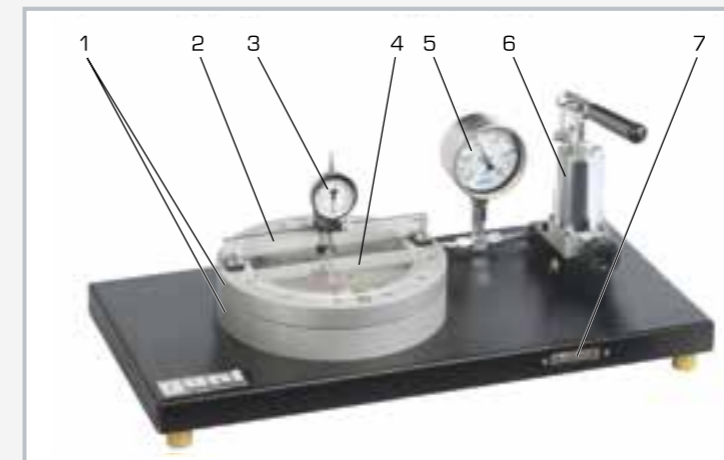

1 clamp for disk, 2 member with scale, 3 dial gauge, 4 disk, 5 manometer, 6 hydraulic pump, 7 port for FL 152 measuring amplifier

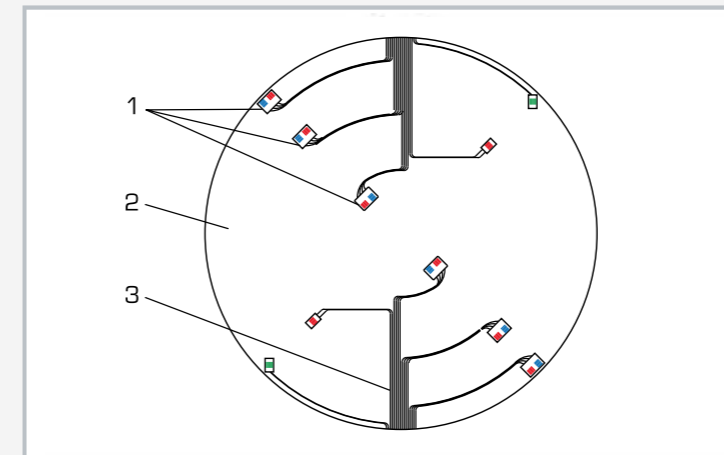

Strain gauge layout on the disk: 1 strain gauge measuring points, 2 disk, 3 wiring, red: strains in the radial direction; blue: strains in the tangential direction, green: shear



Application software in FL 152 for stress analysis: representation of the stress curve

Specification

- [1] investigate the deflection and strain of a thin disk under compressive load
- [2] strain gauges measure in the radial and tangential direction
- [3] strain gauge configured as half-bridge
- [4] possible to measure the deflection at any radius
- [5] measure the deflection via adjustable dial gauge, scale indicates position along the radius
- [6] hermetically sealed hydraulic system, maintenance-free, for generating the compressive load
- [7] hydraulic system with hydraulic pump and manometer
- [8] FL 152 measuring amplifier required
- [9] software for analysing measured values in FL 152

Technical data

Aluminium disk

- outer diameter: $\varnothing=230\text{mm}$
- diameter used in the experiment: $\varnothing=200\text{mm}$
- thickness: 3mm

Strain gauge application

- 8 strain gauges: half-bridges, 350 Ohm
- gauge factor: $2,00 \pm 1\%$
- power supply: 10V

Dial gauge

- 0...20mm
- graduation: 0,01mm

Manometer

- 0...1bar
- accuracy: class 1,0

System pressure

- max. 0,6bar

LxWxH: 700x350x350mm

Weight: approx. 25kg

Scope of delivery

- 1 experimental unit
- 1 set of instructional material

FL 130**Stress and strain analysis on a thin-walled cylinder****Description**

- strain on a vessel under internal pressure
- cylinder with strain gauge application as vessel
- uniaxial or biaxial stress state shown in the experiment

Pipes, pressure vessels, steam boilers etc. are considered as thin-walled vessels during design. The principal stresses are key variables in calculating and designing these vessels. The stresses and strains occurring in a vessel are not directly measured but are determined by measuring the strains on the surface using strain gauges.

The FL 130 experimental unit is used to investigate stresses and strains in a thin-walled vessel subjected to internal pressure. The oil-filled vessel is closed with a lid at one end and with a movable piston at the other end. A hand wheel with a threaded spindle is used to move the piston. Two load cases are presented: biaxial stress state of a closed vessel such as a boiler tank and uniaxial stress state of an open vessel such as a pipe.

Internal pressure is generated inside the vessel by a hydraulic pump. A manometer indicates the internal pressure. Strain gauges are attached to the surface of the vessel to record the strains. The FL 152 measuring amplifier displays the measured values. The measured values can be imported into the application software for visualisation to assist in the evaluation of the experiment.

Mohr's stress circle is used to graphically represent the conversion of the strain and to determine the principal stresses. The principal stresses are calculated from the principal strains by applying the law of elasticity.

Learning objectives/experiments

- measure strains with strain gauges
- application of Mohr's stress circle to determine the principal strain
- determine the principal stresses: axial and circumferential stresses by magnitude and direction
 - ▶ in an open vessel (pipe)
 - ▶ in a closed vessel (boiler)
- comparison of open/closed vessels
- determine Poisson's ratio
- investigation of relations between strains, pressure and stresses in a plane biaxial stress state

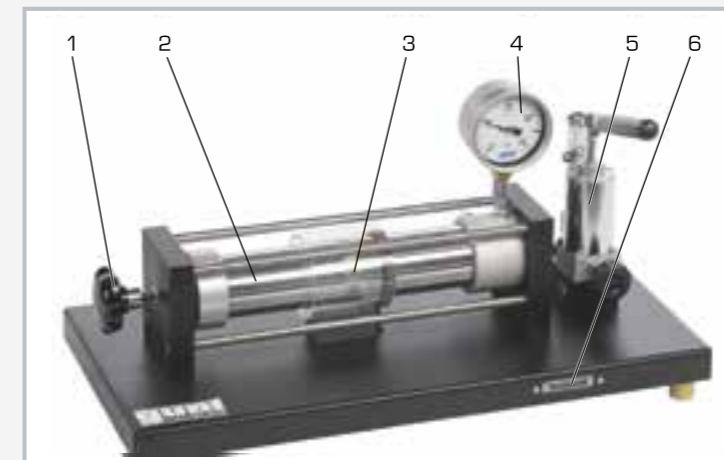

1 hand wheel for adjusting the piston, 2 vessel, 3 strain gauge measuring point, 4 manometer, 5 hydraulic cylinder with hydraulic pump, 6 port for FL 152 measuring amplifier

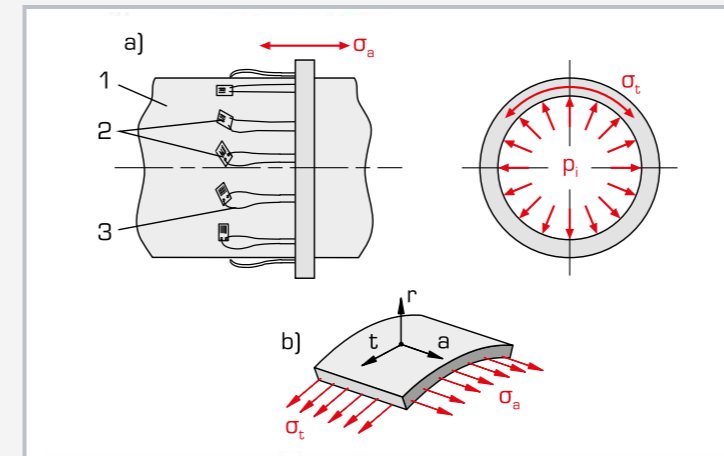

a) Strain gauge layout on the vessel: 1 vessel, 2 strain gauge measuring points, 3 wiring; σ_a stress in the direction of the vessel axis, σ_t stress in the circumferential direction, p_i internal pressure;
b) plane stress state in the wall: a axial direction, t circumferential direction, r radial direction

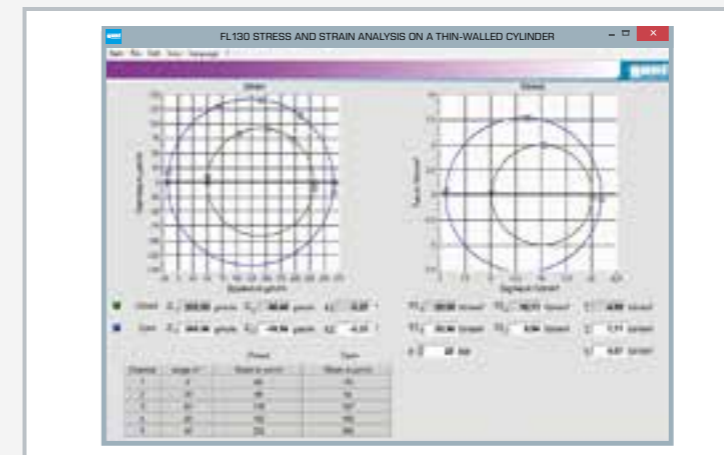

Software screenshot FL 152: Mohr's stress circle

Specification

- [1] investigation of stresses in a thin-walled vessel under internal pressure
- [2] cylinder can be used as open pipe or closed vessel
- [3] strain gauge application on the vessel surface under varying angles
- [4] hermetically sealed hydraulic system, maintenance-free, for generating the compressive load
- [5] hydraulic system with hydraulic pump and manometer
- [6] FL 152 measuring amplifier required
- [7] software for analysing measured values in FL 152

Technical data**Aluminium vessel**

- length: 400mm
- diameter: $\varnothing=75\text{mm}$
- wall thickness: 2,8mm
- internal pressure: max. $3,5\text{N/mm}^2$ (35bar)

Strain gauge application

- 5 strain gauges: half-bridges, 350 Ohm
- angular position to the vessel axis: $0^\circ, 30^\circ, 45^\circ, 60^\circ, 90^\circ$
- gauge factor: $2,00 \pm 1\%$
- power supply: 10V

Manometer

- 0...40bar
- accuracy: class 1,0

LxWxH: 700x350x350mm

Weight: approx. 21kg

Scope of delivery

- 1 experimental unit
- 1 set of instructional material

FL 140

Stress and strain analysis on a thick-walled cylinder



Description

- direct stresses and strains of a thick cylinder under internal pressure
- cylinder with strain gauge application on surface and in wall
- triaxial stress state in cylinder wall

In contrast to thin-walled vessels, when designing thick-walled vessels allowance must be made for an uneven distribution of stresses through the thickness of the wall. The stress state in a thick-walled vessel under internal pressure is triaxial. The direct stresses and strains occur: radial, circumferential, hoop and axial.

Since the stresses and strains occurring in a vessel are not measured directly, they are determined by measuring strains on the surface. Strain gauges are employed to record the strains electrically and the stresses and strains are determined from those measurements.

The FL 140 experimental unit is used to investigate direct stresses and strains occurring on a thick-walled cylinder subjected to internal pressure. The oil-filled cylinder is made up of two halves, and is sealed on both sides. Internal pressure is generated inside the vessel with a hydraulic pump.

A pressure gauge indicates the internal pressure. An eccentric groove is cut between the two halves of the cylinder, in which the strain gauges are mounted at various radial points. Additional strain gauges are mounted on the inner and outer surfaces of the cylinder. Radial, hoop and axial strains are measured, enabling the strain state to be fully recorded.

The measuring amplifier FL 152 displays the recorded signals as measured value readouts. To assist and visualise evaluation of the experiment, the measured values can be imported into the application software.

Mohr's circle for stress and strain analysis is used to represent the triaxial stress state in the cylinder wall graphically. The direct stresses and strains are calculated from the measured strains, applying the appropriate law of elasticity.

Learning objectives/experiments

- measurement of elongations by strain gauges
- application of Mohr's circle for the triaxial stress state
- determination of the distribution of direct stress in
 - ▶ radial, tangential and axial direction
- investigation of correlations between elongation, pressure and stress in the triaxial stress state

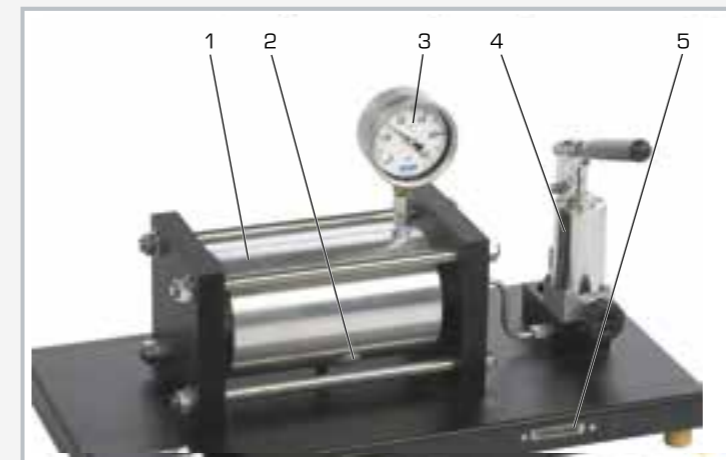

1 cylinder, 2 strain gauge measuring point, 3 pressure gauge, 4 hydraulic pump, 5 connection for measuring amplifier FL 152

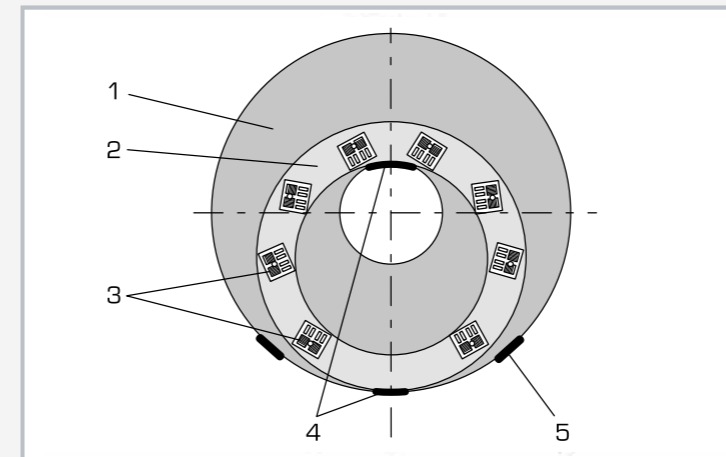

Strain gauge layout in cylinder wall and on the surface:
1 cylinder, 2 eccentric groove, 3 strain gauge measuring point, radial/hoop, 4 strain gauge measuring point, hoop, 5 strain gauge measuring point, axial

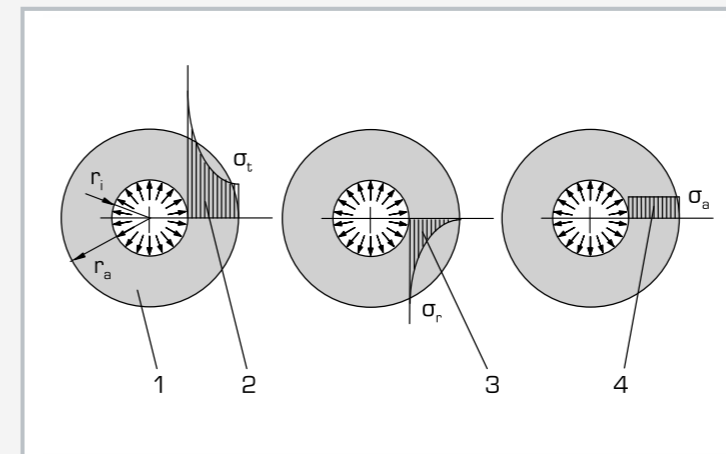

Distribution of stress in cylinder wall: 1 cylinder, r_i inner radius, r_o outer radius, 2 distribution of stress in hoop direction σ_t , 3 distribution of stress in radial direction σ_r , 4 distribution of stress in axial direction σ_a

Specification

- [1] investigation of the stresses and strains in a thick-walled cylinder under internal pressure
- [2] two-part cylinder with flat groove
- [3] strain gauge application at various radial points in the groove and on the cylinder surface
- [4] hermetically sealed hydraulic system, maintenance-free to generate pressure
- [5] hydraulic system with hydraulic pump and manometer
- [6] FL 152 measuring amplifier required
- [7] software for analysing measured values in FL 152

Technical data

Aluminium cylinder

- length: 300mm
- diameter: $\varnothing=140\text{mm}$
- wall thickness: 50mm
- internal pressure: max. 7N/mm^2 (70bar)

Strain gauge application

- 11 strain gauges: half-bridges, 350 Ohm
- gauge factor: $2,00 \pm 1\%$
- supply voltage: 10V

Pressure gauge

- 0...100bar
- accuracy: class 1,0

LxWxH: 700x350x330mm

Weight: approx. 32kg

Scope of delivery

- 1 experimental unit
- 1 set of instructional material

FL 200**Photoelastic experiments with a transmission polariscope**

The illustration shows the experimental unit together with the model from FL 200.03.

Learning objectives/experiments

- together with the accessories or your own models:
 - ▶ generate plane stress states in various models under load: bending, tensile load and compressive load
 - ▶ investigate stress distributions with linear or circular polarised light
 - ▶ interpret photoelastic fringe patterns: stress concentrations, zero points, neutral strands, areas of constant stress and stress gradients
 - ▶ graphically and computationally determine the stresses

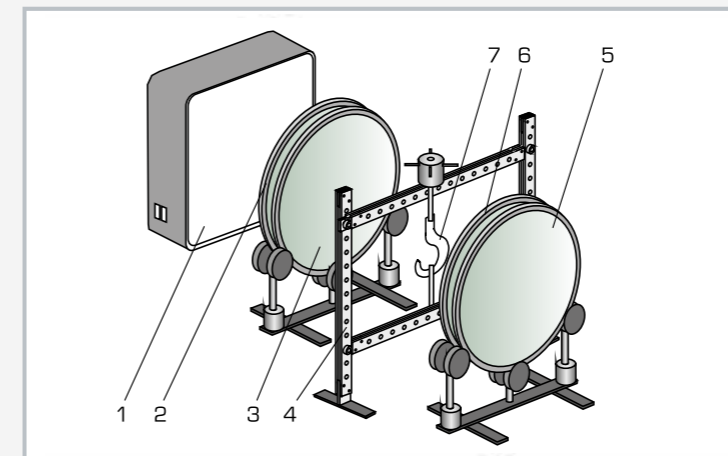

1 light source, 2 polarising filter as polariser, 3 quarter-wave filter, 4 frame for clamping and loading the models, 5 polarising filter as analyser, 6 quarter-wave filter, 7 model under load (FL 200.03)

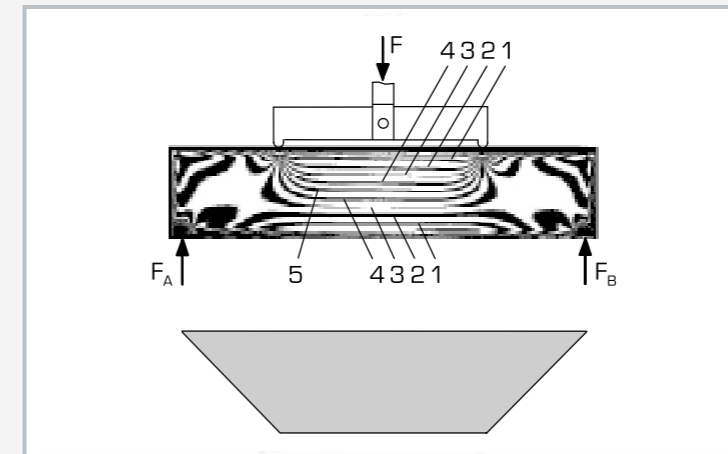
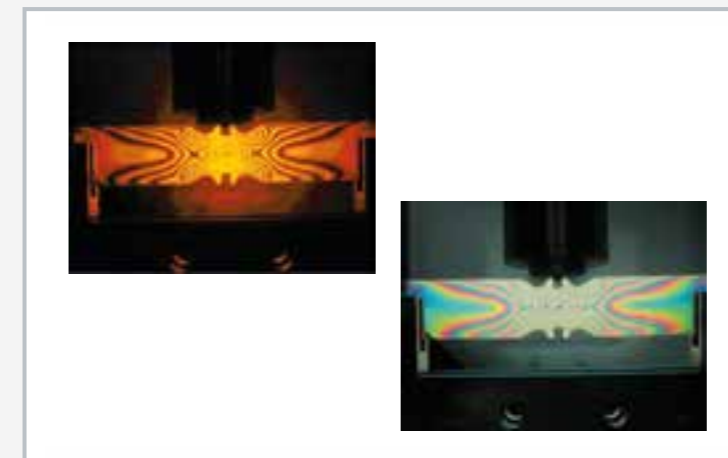
Top: stress distribution in the model under bending load: 1 to 4 isochromat layout, 5 neutral strand; F external force, F_A / F_B support reactions; bottom: bending moment diagram

Top: model of a notched bar (FL 200.05) in monochromatic light, bottom: model FL 200.05 in white light

Specification

- [1] produce the mechanical stress curves through photoelastic experiments
- [2] 2 linear polarising filters (polariser and analyser)
- [3] 2 quarter-wave filters for generating circular polarised light
- [4] all filters have 360° angle scale and indicate the main optical axis
- [5] filters mounted on roller bearings and can be pivoted
- [6] white light produced by a fluorescent tube and two incandescent bulbs
- [7] monochromatic light (yellow) generated by sodium vapour lamp
- [8] frame cross-members can be vertically adjusted
- [9] pressure or tensile forces generated by a threaded spindle
- [10] finished polycarbonate (PC) models available as accessories for the demonstration

Technical data

Light source

- lamp box with white diffuser
- for white light
 - ▶ 1 fluorescent tube TL-E 32W/33 (colour: 33)
 - ▶ 2 incandescent bulbs, candle lamp, frosted E14, 230V, 25W
- for monochromatic light (yellow)
 - ▶ 1 sodium vapour lamp SOX 35, 35W

Filter, mounted in glass, diameter: Ø 425mm

- 2 polarising filters (dark olive)
- 2 quarter-wave filters (uncoloured)

Frame: WxH: 600x750mm

230V, 50Hz, 1 phase
 230V, 60Hz, 1 phase; 120V, 60Hz, 1 phase
 UL/CSA optional
 LxWxH: 800x600x750mm
 Weight: approx. 50kg

Scope of delivery

- 1 frame with load application device
- 2 polarising filters
- 2 quarter-wave filters
- 2 filter mounts
- 1 light source
- 1 set of accessories
- 1 set of instructional material

Description

- monochromatic or white light
- generate stress patterns with linear or circular polarised light
- models for specific problems can be prepared by the user

Photoelasticity is a proven method of analysing and recording mechanical stresses and strains in components. It is used both for quantitative measurements and for demonstrating complex stress states. The components used are models made of a transparent, photoelastically sensitive plastic, which becomes optically birefringent under mechanical load.

FL 200 is used to conduct photoelastic experiments on plane, transparent plastic models. The models are subjected to load by external forces, and they are radiated by circular polarised light.

An analyser analyses the light penetrating the body.

The experimental setup comprises the separate components: a light source, two linear polarising filters (polariser and analyser), two quarter-wave filters and a frame in which the models are attached and subjected to load. The light source optionally permits coloured stress patterns with white light or a light/dark representation with monochromatic light.

The polariser includes a polarising filter and a quarter-wave plate and generates circular polarised light. Behind the model is a second quarter-wave plate (perpendicular to the first one), which is combined with a second polarising filter. These form the analyser. The filters are mounted on rotating bearings and fitted with angle scales.

Various polycarbonate models are mounted inside the frame. A load application device applies bending, tensile or compressive load to the model through a spindle. Stresses and strains occurring in the model are identifiable as bright spots, visualising the distribution of stress. The order of the dark isochromats is analysed to determine the principal stress differential.

A wide selection of models such as notched bars, a wrench and a model-roller bearing or a rack-and-pinion is available as accessories. These ensure the implementation of comprehensive experiments. It is also possible to investigate your own models.

FL 210

Photoelastic demonstration



The illustration shows the FL 210 device with a normal overhead projector, which is not part of the scope of delivery.

Learning objectives/experiments

- generate plane stress states in various models under load
 - ▶ compressive load
 - ▶ tensile load
- investigate stress distributions with linear and circular polarised light
- interpret photoelastic fringe patterns
 - ▶ stress distribution
 - ▶ stress concentration

Description

- **demonstration unit as an attachment for an overhead projector**
- **generate stress patterns with linear or circular polarised light in typical polycarbonate components**
- **detect stress concentrations**

Photoelasticity can be used to demonstrate stress profiles and stress concentrations in component models.

The distribution of stress in plane, transparent bodies (plastic models) is investigated using polarised light. Polarising filters represent the stress profiles in colour. The notching and point loading and the criteria dictating component design are clearly visualised.

The FL 210 unit can be used with overhead projectors.

Various transparent plastic models are mounted inside a frame. A load application device is used to apply pressure or tensile loads to the model under investigation through a spindle.

An arrangement of polarising filters and quarter-wave filters generates either linear or circular polarised light. A green filter to generate monochromatic light is also part of the scope of delivery. The light source is an overhead projector (e.g. FL 210.01).

The use of monochromatic light produces a system of dark and light stripes, which reflect the distribution and magnitude of mechanical stresses. The models which belong to the scope of delivery represent typical components, permitting experimentation in relation to notching and point loading. The stress profiles shown on the model are identical to those in real-world components.

Additional models are also available to represent stress profiles in roller bearings, tooth flanks, screw connections and wrenches.

All parts of the experiment are clearly laid out and securely housed in a storage system.

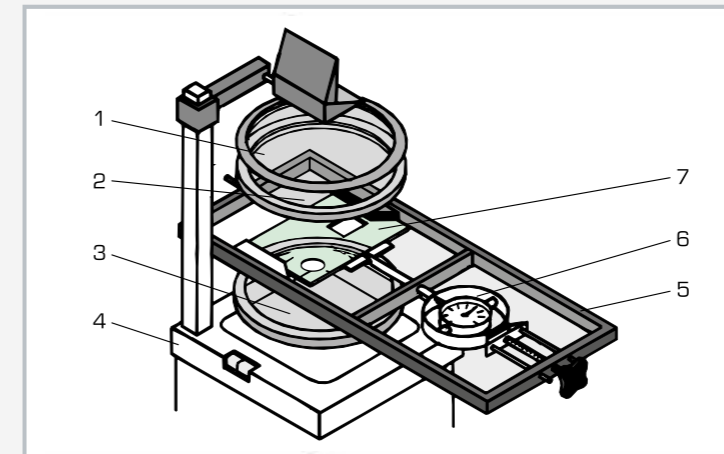

1 green filter, 2 analyser, 3 polariser, 4 overhead projector (FL 210.01), 5 frame, 6 load application device with force gauge, 7 plastic model

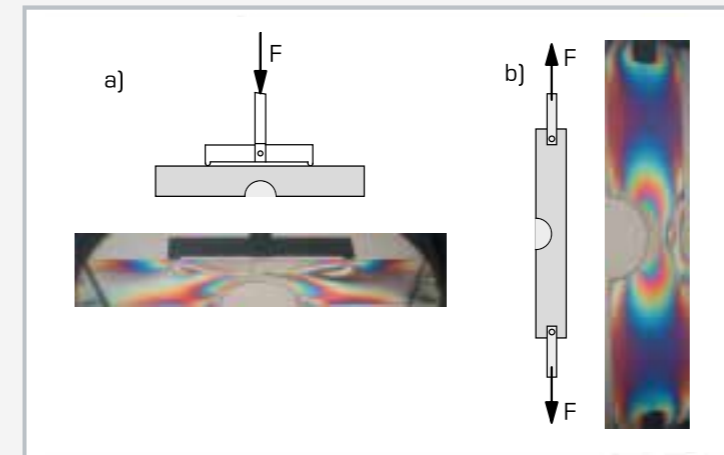

a) model under bending load, stress profile
b) model under tensile load, stress profile

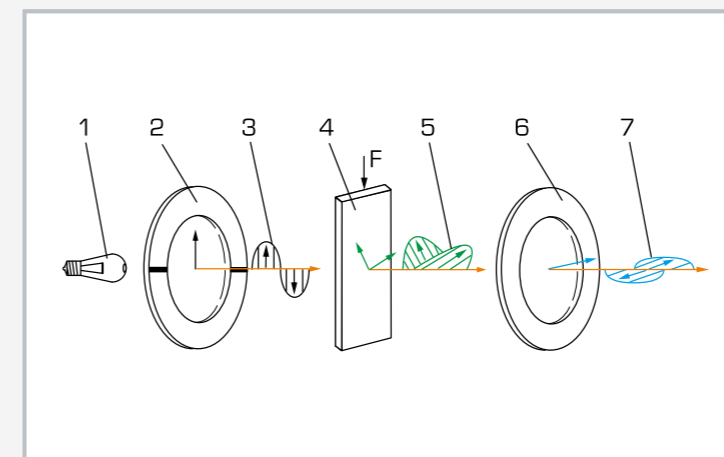

Schematic representation of the photoelastic demonstration:
1 light source, 2 polariser, 3 linear polarised light, 4 model under load, 5 light decomposed into two components in the directions of the principal stresses, 6 analyser, 7 horizontal components of the light

Specification

- [1] photoelastic experiments with an overhead polariscope
- [2] polariser and analyser each comprise a polarising filter and a quarter-wave filter
- [3] filter enclosed, with stress-free glazing
- [4] all filters arbitrarily rotatable in the horizontal plane
- [5] linear or circular polarised light possible
- [6] green filter for monochromatic light
- [7] load application device with force gauge for pressure and tensile load
- [8] eight different polycarbonate models are delivered
- [9] storage system for parts

Technical data

Filter bracket with polariser and analyser

- diameter of filters: \varnothing 165mm

1 green filter, diameter: \varnothing 150mm

Load application device with force gauge

- load force: 0...250N

8 models, PC

- unnotched bar
- bar with hole
- bar notched on one side
- bar notched on both sides
- rectangle without recesses
- rectangle with recesses
- fork
- crane hook

LxWxH: 500x190x30mm (frame)

LxWxH: 280x280x90mm (filter bracket)

Weight: approx. 8kg





LxWxH: 1170x480x178mm (storage system)

Scope of delivery

- 1 frame with load application device
- 1 filter bracket with polariser and analyser
- 1 green filter
- 8 photoelastic models
- 1 storage system with foam inlay
- 1 set of instructional material

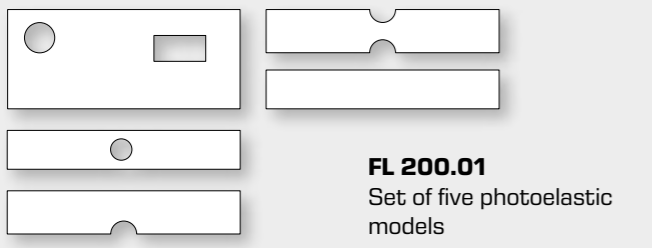
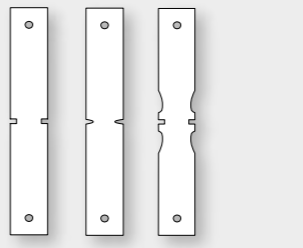
FL 200 and FL 210 Representation of stress distribution in component models

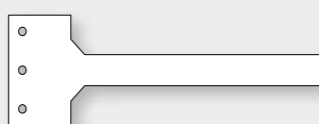
Models for photoelastic experiments with a transmission polariscope (FL 200)

 <p>FL 200.01 Set of five photoelastic models</p>	 <p>FL 200.05 Set of three photoelastic models, comparison of notches</p>
 <p>FL 200.02 Model – arch, PC</p>	 <p>FL 200.06 Model – stresses on weld seams, PC</p>
 <p>FL 200.03 Model – crane hook, PC</p>	 <p>FL 200.07 Model – wrench, PC</p>

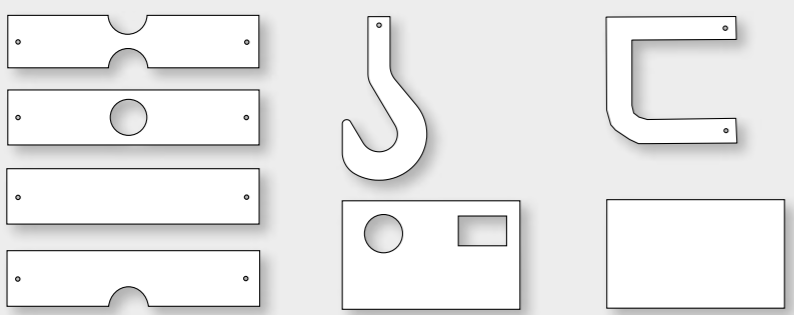

Models for photoelastic demonstrations with an overhead projector (FL 210)

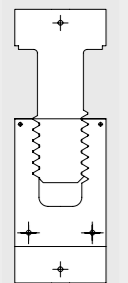
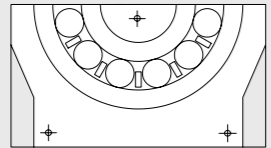
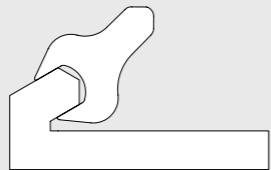
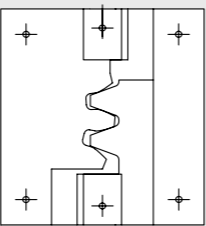

Additional models as accessories

 <p>FL 210.10 Model – bolted connection</p>	 <p>FL 210.11 Model – roller bearing</p>	 <p>FL 210.12 Model – wrench with counterpart</p>	 <p>FL 210.13 Model – pinion</p>
---	--	--	--

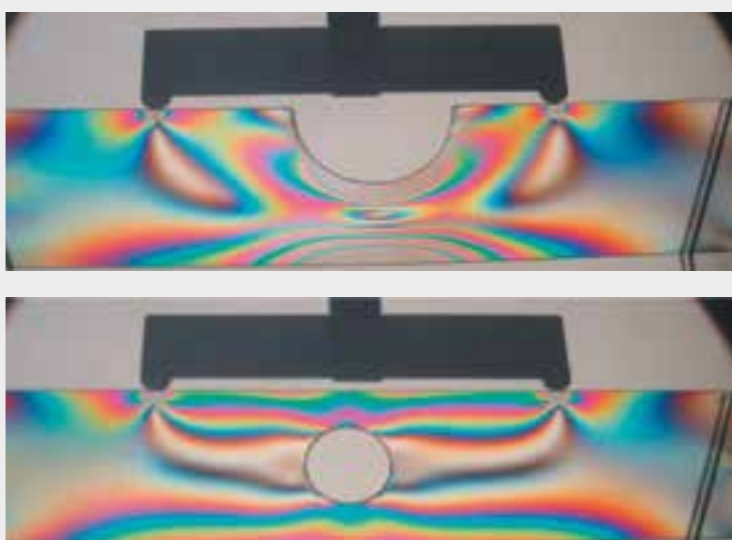
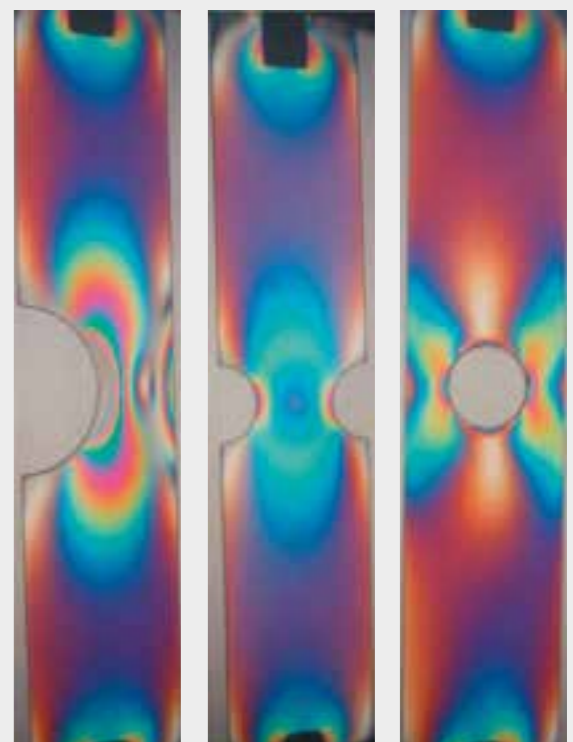
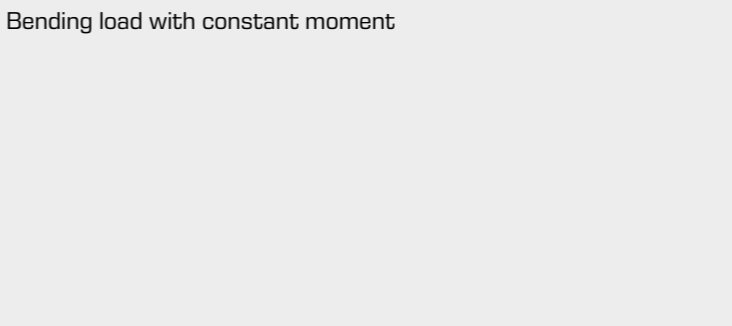
Models for photoelastic demonstrations and experiments under load (FL 200 and FL 210)

 <p>Bending load with constant moment</p>	 <p>Tensile load with stress concentration on cross-sectional contraction</p>
 <p>Bending load with central force and cross-sectional contraction</p>	 <p>Crane hook under load</p>

3 Engineering mechanics – dynamics

Introduction

Basic knowledge Kinematics and kinetics	144
---	-----

Kinematics

KI 110 Kinematic model: crank mechanism	146
KI 120 Kinematic model: crank slider	147
KI 130 Kinematic model: four-joint link	148
KI 140 Kinematic model: Whitworth quick return mechanism	149
KI 150 Kinematic model: Hooke's coupling	150
KI 160 Kinematic model: Ackermann steering mechanism	151
GL 105 Kinematic model: gear drive	152

Kinetics: basic experiments on dynamics and moment of inertia

TM 610 Rotational inertia	154
TM 611 Rolling disk on inclined plane	155
TM 612 Kinetic model: flywheel	156
GL 210 Dynamic behaviour of multistage spur gears	158
GL 212 Dynamic behaviour of multistage planetary gears	160

Kinetics: dynamics of rotation

TM 600 Centrifugal force	162
TM 630 Gyroscope	164
TM 605 Coriolis force	166
TM 632 Centrifugal governor	168

Vibrations

Basic knowledge Vibrations	170
TM 161 Rod and gravity pendulum	172
TM 162 Bifilar/trifilar suspension of pendulums	173
TM 163 Torsional vibrations	174
TM 164 Coil spring vibrations	175
Overview TM 150 Vibration trainer	176
TM 150 Vibration trainer	178
TM 150.20 System for data acquisition	180
SE 110.58 Free vibrations in a bending beam	181

Basic knowledge

Kinematics and kinetics

Dynamics

While statics deals with bodies in equilibrium, i.e. which are at rest or moving with constant velocity, dynamics deals with the accelerated motion of a body caused by forces. As such, time plays a key role in dynamics. In dynamics, both the forces acting on a body and the resulting motions of the body are considered. Knowledge of dynamics is needed in all areas of mechanical engineering.



Dynamics comprises kinetics and kinematics. In practice, the difference between kinematics and kinetics is the way of looking at the same machine or component. Kinematic questions only consider the geometry of the motion. Kinetics also takes into account the cause of the motion.

The aim of dynamics is to calculate the stress and strain on components or systems in order to be able to design them.



Kinematics

Kinematics describes and analyses the effect of motion on bodies, without taking into account the causes; it focuses on the geometric aspects of the motion. Coordinates describe the position of the body at any point in time. The path, velocity and acceleration are considered.

In engineering, we distinguish between two forms of motion: **translation** and **rotation**. Most components of a machine undergo a combination of these two forms: general planar motion. This is illustrated by a simple piston engine:



In practice, knowledge of kinematics is required for the construction and design of crank mechanisms, disk cams or gears. Only when the kinematics of a rigid body is fully understood, is it possible to apply motion equations that link forces on the body to motion.

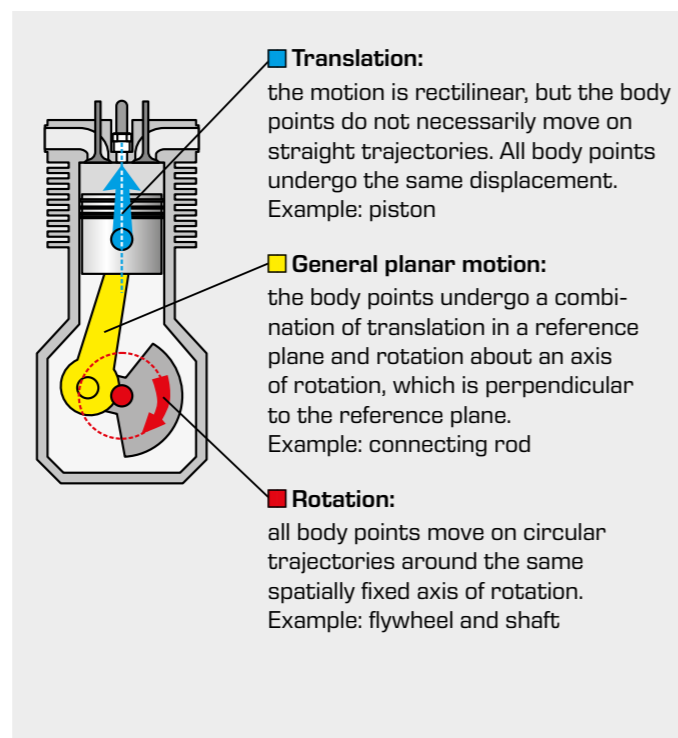

Kinetics

Kinetics studies movements under the influence of forces; therefore, the cause of the motion is taken into consideration. To describe the spatial and temporal evolution of a mechanical system acted on by external forces, we use equations of motion. These generally comprise a system of second-order differential equations.

Kinetics are primarily based on **Newton's laws** of motion

1st law: principle or law of inertia

Without external force, a body remains at rest or in rectilinear uniform motion. Inertia: the body only changes its state of motion under the action of an external force.

2nd law: principle of action

The acting force and the acceleration achieved are proportional to each other. The ratio of the acting force to the acceleration achieved is constant for every body and equals its mass.

Fundamental law of dynamics:
force = mass · acceleration
 $F = m \cdot a$

3rd law: principle of reaction or interaction

Reaction forces between two mass points are equal in magnitude, opposite in direction and collinear.

actio = reactio

Newton's fundamental law: **$\sum F = m \cdot a$**

Mass moment of inertia:

In translation, we refer to the inertia of a body; in rotation, this inertia corresponds to the mass moment of inertia.

If the rotational motion of a rigid body about a given axis is changed, the body resists the change. This resistance is given by the mass moment of inertia. Here, the behaviour of the body depends on its mass and its distribution relative to the axis of rotation. Both the mass and its distribution must be known to calculate the mass moment of inertia.

$$J = \frac{M}{\alpha}$$

$$J = r^2 \Delta m$$

J mass moment of inertia, **M** turning moment, **F** force, **α** angular acceleration, **r** radius, **Δm** circumferential mass point

This behaviour is illustrated using the example of a tractor's flywheel mass; with regard to its axis of rotation, the flywheel mass has a large mass moment of inertia. If the flywheel mass has been set in motion, a large force must be applied to stop it. Consequently, the engine only delivers a largely constant power at low speeds and stalling is prevented.



KI 110

Kinematic model: crank mechanism



Learning objectives/experiments

- crank mechanism with fixed and oscillating cylinder

Specification

- [1] investigation of a crank mechanism
- [2] adjustment of the crank radius at three positions of the crank on the crank disk
- [3] adjustment of the angle by turning the crank disk
- [4] measure the stroke on the cylinder
- [5] pivoting cylinder can be blocked to study the crank mechanism with either a fixed or oscillating cylinder

Technical data

- Crank disk
- anodised aluminium
 - mounted on ball bearings

Crank radius

- 25mm
- 37,5mm
- 50mm

Connecting rod

- aluminium, anodised black

Cylinder

- stroke 0...100mm

LxWxH: 360x280x70mm

Weight: approx. 2kg

Scope of delivery

- 1 kinematic model
- 1 set of instructional material

Description

■ crank mechanism with fixed or oscillating cylinder

The crank mechanism is the functional group of machines that converts a uniformly rotating (rotational) motion into a reciprocating (translational) motion or vice versa. Crank mechanisms are used in engines, pumps or presses.

The KI 110 unit can be used to demonstrate this conversion with either a fixed or oscillating cylinder. The experimental unit comprises a crank disk, connecting rod and cylinder. The connecting rod is connected to the crank disk on one side via a crank. Changing the position of the crank on the crank disk adjusts the crank radius in three positions.

At the other end, the connecting rod is connected to the cylinder. This end models the piston. Simply turning a screw makes it possible to block the pivoting cylinder and, thus, to demonstrate a crank mechanism with either a fixed or oscillating cylinder.

The angle is adjusted using the crank disk; an angle scale is integrated into the base plate. A millimetre-precise steel ruler is attached to the cylinder to measure the stroke.

The elements are mounted on a base plate. Two handles make it easy to carry and stack the unit.

KI 120

Kinematic model: crank slider



Learning objectives/experiments

- conversion of a uniform rotary motion into a purely harmonic reciprocating motion
- influence of crank length and input angle on the output stroke
- recording the transmission function of a crank slider

Specification

- [1] investigation of a crank slider
- [2] generation and investigation of purely harmonic stroke movements
- [3] adjustment of the crank radius at three positions of the connecting rod on the crank disk
- [4] adjustment of the angle by turning the crank disk
- [5] measure the stroke on the cylinder

Technical data

- Crank disk
- anodised aluminium
 - ball-bearing mounted

Crank radius

- 25mm
- 37,5mm
- 50mm

Connecting rod

- anodised aluminium

Cylinder

- stroke 0...100mm

LxWxH: 380x280x100mm

Weight: approx. 3kg

Scope of delivery

- 1 kinematic model
- 1 set of instructional material

Description

■ representation of a purely harmonic reciprocating motion

The crank slider, unlike a normal crank mechanism, generates a purely harmonic stroke movement.

The KI 120 unit can be used to generate and study purely harmonic stroke movements. The experimental unit comprises a rotating crank disk, connecting rod and fixed cylinder. The connecting rod is connected to the crank disk on one side via a crank. Changing the position of the crank on the crank disk adjusts the crank radius in three positions.

At the other end, the connecting rod is connected to the fixed cylinder. This end models the piston. The angle is adjusted using the crank disk, and an angle scale is integrated into the base plate. A millimetre-precise steel ruler is attached to the cylinder to measure the stroke.

The elements are mounted on a base plate. Two handles make it easy to carry and stack the unit.

KI 130**Kinematic model: four-joint link****Learning objectives/experiments**

- investigation of the mechanical relationships on the four-joint link
- investigation of the principle of the crank-rocker mechanism, double rocker mechanism and double crank
- verification of the Grashof condition by varying the crank radius, oscillation radius and coupling length

Specification

- [1] investigation of a four-joint link
- [2] adjustment of the crank radius at three positions of the crank on the drive disk
- [3] adjustment of the oscillation radius at three positions
- [4] adjustment of the coupling length at five positions
- [5] adjustment of the input angle by turning the drive disk
- [6] measure the output angle on the angle scale of the output disk

Technical data

Drive disk and output disk

- anodised aluminium
- ball-bearing mounted

Crank radius

- 25mm, 37,5mm, 50mm

Rocker

- aluminium, anodised black
- oscillation radius: 50mm, 100mm, 200mm

Coupling

- aluminium, anodised black
- length: 60mm, 160mm, 180mm, 200mm, 220mm

LxWxH: 380x280x100mm
Weight: approx. 3kg

Scope of delivery

- 1 kinematic model
- 1 set of instructional material

Description**■ conversion of rotary motion into oscillating motion**

The four-joint link is a four-bar pivot gear. It converts rotary motion into oscillating motion.

The KI 130 unit can be used to investigate the crank-rocker mechanism, the double rocker mechanism and the double crank.

The experimental unit comprises the drive disk with the crank and coupling and the output disk with the rocker. The elements are connected to each other via pivot joints. The positions of the pivot joints can be varied to adjust the crank radius, oscillation radius and coupling length. The drive disk can be driven by the crank.

The input angle is adjusted using the drive disk, and an angle scale is integrated into the base plate. The output angle is read at the angle scale on the output disk.

The elements are mounted on a base plate. Two handles make it easy to carry and stack the unit.

KI 140**Kinematic model: Whitworth quick return mechanism****Learning objectives/experiments**

- investigation of a revolving crank slider
- influence of crank length and input angle on the output stroke
- recording the transmission function of a revolving crank slider

Specification

- [1] investigation of a revolving crank slider
- [2] generation and investigation of non-uniform stroke movements
- [3] adjustment of the crank radius at three positions of the connecting rod on the crank disk
- [4] adjustment of the angle by turning the crank disk
- [5] measuring the stroke on the cylinder
- [6] base plate with handles

Technical data

Drive disk

- anodised aluminium
- ball-bearing mounted

Crank radius

- 46mm

Slider radius

- 55mm

Driving rod

- anodised aluminium
- length: 145mm

Cylinder/driving rod/frame

- stroke 0...100mm

LxWxH: 360x280x70mm
Weight: approx. 2kg

Scope of delivery

- 1 kinematic model
- 1 set of instructional material

Description**■ representation of a non-uniform reciprocating motion**

The Whitworth mechanism is also known as the quick-return mechanism. It represents a revolving crank slider and produces non-uniform stroke movement with slow forward movement and fast backward movement. This mechanism is used in tools, packaging and transport machinery.

The KI 140 unit generates non-uniform stroke movement by means of a Whitworth mechanism. The experimental unit comprises the drive disk with crank and coupling, the driving rod and the cylinder.

The angle is adjusted using the crank disk, and an angle scale is integrated into the base plate. A millimetre-precise steel ruler is attached to the cylinder to measure the stroke.

The elements are mounted on a base plate. Two handles make it easy to carry and stack the unit.

KI 150**Kinematic model: Hooke's coupling****Learning objectives/experiments**

- representation of the non-uniform transmission of a universal joint
- determine the gimbal error
- how the arrangement of the universal joints and the deflection angle affect the gimbal error

Specification

- [1] investigation of a universal joint shaft
- [2] adjustment of the layout of the universal joints and the deflection angle via two rotary plates
- [3] adjustment of the input angle of the drive universal joint
- [4] measure the output angle of rotation
- [5] determine the angular difference

Technical data

Universal joint

- quantity: 2
- standard parts to DIN 808
- stainless steel

Shaft

- quantity: 3
- diameter: 16mm
- stainless steel
- ball bearings

LxWxH: 360x280x200mm

Weight: approx. 3kg

Scope of delivery

- 1 kinematic model
- 1 set of instructional material

Description**■ investigation of a universal joint shaft**

Universal joint shafts are joint shafts that transfer a torque and a rotational motion. A universal joint combines two non-aligned shafts. In a universal joint, the torque and the speed are non-uniformly transmitted. This non-uniform transmission is called the gimbal error. This is remedied by using two universal joints connected to each other by an intermediate shaft. This combination is referred to as the cardan shaft or the universal joint shaft.

The KI 150 unit can be used to study a universal joint shaft. A universal joint is also known as Hooke's coupling. The experimental unit comprises two universal joints with intermediate shafts. The arrangement of the universal joints and the deflection angle can be set using two rotary disks on the base plate.

On the drive side, the input angle is set and read by the drive universal joint. The intermediate shaft transmits the torque to the driven universal joint. The output rotation angle is read. The gimbal error is determined from the difference between the two angles.

The elements are mounted on a base plate. Two handles make it easy to carry the unit.

KI 160**Kinematic model: Ackermann steering mechanism****Learning objectives/experiments**

- verifying Ackermann's steering principle
- calculate the wheelbase
- determine the lead angle and the steering error

Specification

- [1] investigate a steering trapezoid
- [2] investigate the steering geometry according to Ackermann
- [3] adjustment of the track rod lengths
- [4] read the steering angle on the scales
- [5] adjustment of the zero position of the steering angle by locking the mechanism
- [6] adjustment of the steering angle of the inside wheel
- [7] measure the steering angle of the outside wheel
- [8] base plate with handles suitable as benchtop model and for wall mounting

Technical data

Track rods

- individually adjustable

Distance between the steering pins

- 465mm

Measuring range of the steering angle

- $\pm 50^\circ$
- scale graduation: 1°

LxWxH: 620x280x60mm

Weight: approx. 6kg

Scope of delivery

- 1 kinematic model
- 1 set of instructional material

Description**■ investigation of the steering geometry according to Ackermann**

When it comes to steering, the entire vehicle's wheel should be exactly on a circular path. To achieve this, the extensions of all the axles must intersect at the centre of the circle (Ackermann's steering principle). This requires that the wheel inside of the curve drives more than the wheel outside of the circle. This is approximately achieved with a steering trapezoid, comprising an axle, a track rod and two track-rod arms on the wheels.

The KI 160 unit can be used to study a steering trapezoid. The experimental unit comprises two track rods with drag link, two track-rod arms and two steering pins, where, in theory, the wheels are attached. The length of the axis corresponds to the distance between the steering pins.

The lengths of the two track rods are independently adjustable.

To set the zero position of the steering angle, the mechanism is fixed via a lock on the drag link. The steering angle on the inside wheel is set; the angle of the outside wheel changes according to the geometry and is read. The difference between the two angles is the lead angle or relative steering angle. The difference between the calculated and measured steering angles is the steering error. Disadvantages of an incorrectly set track rod can be demonstrated.

The elements are mounted on a base plate, which can also be mounted on a wall.

GL 105**Kinematic model: gear drive****Description**

- investigation of single-stage and multistage spur gears
- investigation of planetary gears

The gear is the element of a machine that transmits and transforms motion. A gear comprises at least one drive, an output and a frame.

Gear drives are uniform translation gears. The rotary motion is transferred from one shaft to a second through positive transmission by gears.

In spur gears, the gears are mounted on parallel axles. The drive and the output shaft are arranged in parallel. Planetary gears are a type of spur gears, in which the drive and the output shafts are on the same axle.

The GL 105 experimental unit can be used to study gear drives in the form of spur or planetary gears. The unit focuses on the consideration of kinematics. The experimental unit consists of a base plate with a fixed axle, on which is mounted a pivoting rail. Two other axles can be attached at any position on this rail. Selecting and combining the gears with different numbers of teeth allows you to realise different transmission ratios and gear types.

The rail is locked in experiments with spur gears. Depending on the aim of the experiment, one or two additional axles can be positioned on the rail. The gears can be coupled to each other via driving pins or to the fixed axle. It is driven by hand. The full revolutions are counted to determine the transmission ratio.

To investigate planetary gears, the rail is released and pivoted about the fixed axle. The rail serves as a planetary wheel support on which the planetary wheels are positioned and represents the input of the gear. The sun wheel forms the output of the gear. It is driven by hand. The transmission ratio can be determined by counting the full revolutions.

Learning objectives/experiments

- investigation of single-stage or multistage spur gears
- investigation of planetary gears
- determine the transmission ratio

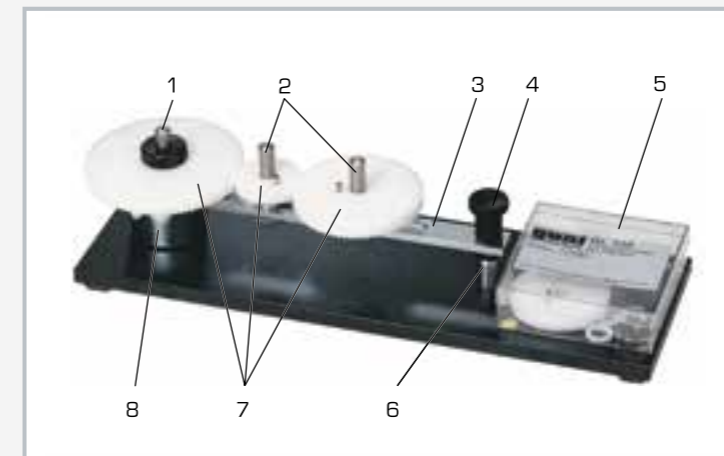

1 fixed axle, 2 additional axles arranged at any point, 3 rail, 4 handle, 5 storage box, 6 rail lock, 7 gears, 8 bearing

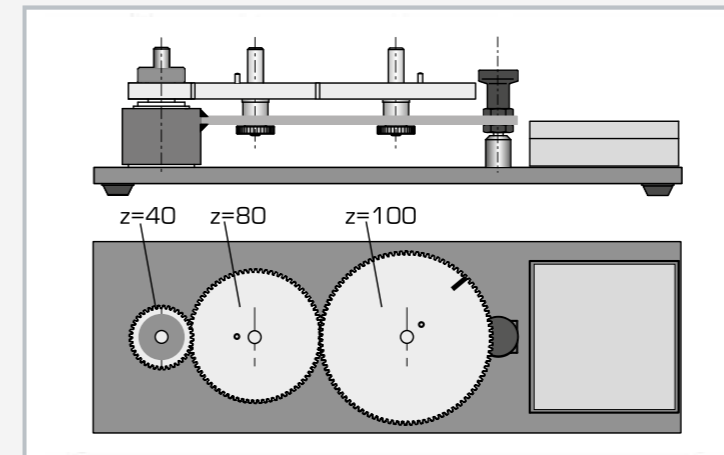

Experimental setup with locked rail and two additional axles
Gear with intermediate wheel: driving wheel (40 teeth), intermediate wheel (80 teeth), driven wheel (100 teeth)

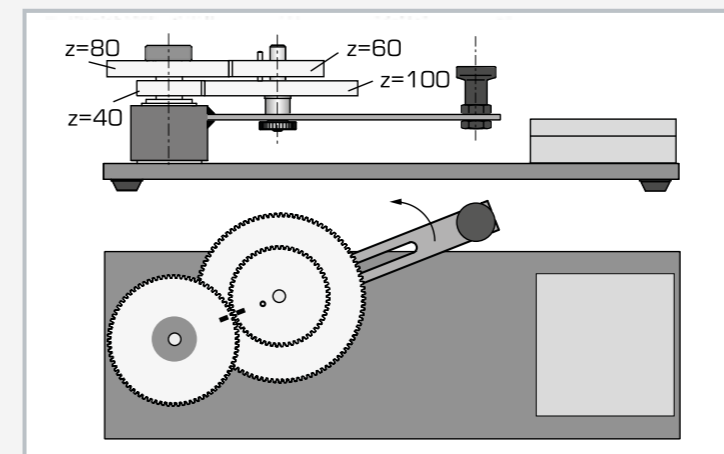

Experimental setup with unlocked rail and one additional axle
Planetary gear: driven wheel (40 teeth) coupled to the fixed axle, driven via rail, rail as planetary gear, planetary wheels (100 teeth, 60 teeth), sun wheel as driven wheel (80 teeth)

Specification

- [1] investigation of single-stage or multistage spur gears
- [2] investigation of planetary gears
- [3] driven by hand
- [4] determine the transmission ratio by counting the revolutions of the driven gears
- [5] base plate with storage for components

Technical data**Gears**

- quantity: 4
- plastic
- module: 1 mm
- number of teeth: 40, 60, 80 and 100

LxWxH: 380x120x100mm

Weight: approx. 3kg

Scope of delivery

- 1 kinematic model
- 1 set of instructional material

TM 610

Rotational inertia



Learning objectives/experiments

- investigation of the inertia of rigid bodies in rotational motion
- determine mass moments of inertia of different, regularly shaped bodies
- investigation of the mass moment of inertia as a function of the radius

Specification

- [1] investigation of the inertia of various bodies in rotational motion
- [2] hollow cylinder, solid cylinder or rotating bar with masses as a rotating body
- [3] generate a uniformly accelerated rotational motion via weight, pulley and cable drum
- [4] rotating bar: adjustable position of the mass to realise different radii
- [5] measure the time and the acceleration distance
- [6] position and fix the parts via table clamps

Technical data

- Rotating bar
- length: 550mm
 - masses: 2x 0,1kg, 2x 0,2kg, 2x 0,4kg

- Solid cylinder
- diameter: 120mm
 - mass: 0,9kg

- Hollow cylinder
- outer diameter: 120mm
 - inner diameter: 110mm
 - mass: 0,9kg

- Weight for the drive
- 1N

- LxWxH: 730x180x480mm (set-up)
Weight: approx. 13kg

Scope of delivery

- 1 experimental unit
- 1 set of instructional material

Description

■ investigation of mass moments of inertia in rotating, rigid bodies

The resistance with which a rigid body opposes a change to its rotation is indicated by the mass moment of inertia. Here, the behaviour of the body depends on its mass and the distribution of this mass relative to the axis of rotation. Mathematically, the quotient of the rotary moment and the angular acceleration is the mass moment of inertia.

The TM 610 unit can be used to study mass moments of inertia of rotating bodies (hollow cylinder or solid cylinder). The experimental unit is clamped to a table-top plate via two support rods.

A support rod supports the rotary axis with the studied body. The rotary axis is accelerated by a weight, pulley and cable with a drum. This results in a uniformly accelerated rotational motion. Using the measured time, mass and acceleration distance, we can calculate the mass moment of inertia. Systems with different masses and mass distributions can be studied in various geometries.

Using a rotating bar with masses, it is possible to study the mass moment of inertia as a function of the radius.

TM 611

Rolling disk on inclined plane



Learning objectives/experiments

- proof of the law of falling bodies on the inclined plane
- influence of the mass of a body on its acceleration
- determine the mass moment of inertia by rolling experiment and pendulum experiment
- Steiner's theorem

Specification

- [1] investigation of inertia in rotational motion
- [2] proof of the law of falling bodies
- [3] experimentally determine the mass moments of inertia
- [4] rolling experiments on an inclined plane with height adjustment and three-point support
- [5] pendulum experiments with a physical pendulum
- [6] goniometer and spirit levels ensure precise alignment
- [7] measure the time and the acceleration distance

Technical data

- Roll track
- length: max. 1000mm
 - angle of inclination: 0°...7°

- Disks
- mass: 320g and 620g
 - diameter: 70mm and 100mm

- Rotary axis
- diameter: 10mm
 - distance to centre of gravity: 10mm

- LxWxH: 1180x480x210mm
Weight: approx. 10kg

Scope of delivery

- 1 experimental unit
- 1 set of weights
- 1 set of instructional material

Description

■ inertia in rotational motion on an inclined plane and in a physical pendulum

The mass moment of inertia is a proportionality constant, which depends on both the body and the position of the body's rotation axis. By measuring the rotary moment and the resulting angular acceleration, we can experimentally determine the mass moment of inertia. To do this, the TM 611 unit offers rolling experiments on an inclined plane and pendulum experiments with a physical pendulum to determine mass moments of inertia experimentally. In the rolling experiment, the inclination of the inclined plane is set through height adjustment and read on a goniometer.

A disk rolls down the track. The time and the acceleration distance are measured, and the mass moment of inertia is calculated.

To conduct the pendulum experiments, the disk is hung in a mount. The rotation axis of the disk is displaced by a specific distance from the centre of gravity. The disk is deflected and rolls back and forth in a pendulum motion. The mass moment of inertia is calculated from the measured time during the swaying, the mass and the distance to the centre of gravity (Steiner's theorem).

Two different disks are available. The experiments are precisely aligned with spirit levels.

TM 612

Kinetic model: flywheel



Learning objectives/experiments

- determine the mass moment of inertia by experiment
- dynamic fundamental law of rotational movement

Specification

- [1] investigate the inertia of a flywheel
- [2] generate a uniformly accelerated rotational motion of the flywheel
- [3] driven by weights
- [4] influence of weight on time taken to roll down
- [5] measure the time and the acceleration distance
- [6] determine the mass moment of inertia
- [7] bracket for wall mounting

Technical data

Flywheel

- diameter: 300mm
- thickness: 40mm
- mass: 22,2kg

Shaft

- diameter: 22mm

Weight for the drive

- 1x 1N (hanger)
- 4x 1N
- 3x 5N

LxWxH: 250x350x1500mm

Weight: approx. 30kg

Scope of delivery

- 1 experimental unit
- 1 set of weights
- 1 set of instructional material

Description

■ investigation of uniformly accelerated rotational motion

The resistance with which a rigid body opposes a change to its rotation is indicated by the mass moment of inertia. It is a measure of the inertia of a body in rotation. Using the TM 612 kinetic model, we can conduct basic experiments on uniformly accelerated rotational motion.

The experimental unit comprises a flywheel with shaft, a cable and a set of weights. The shaft forms the axis of rotation in the centre of gravity of the flywheel. It is mounted on two bearings. One end of the cable is attached to the shaft. A weight is attached to the other end. The attached weight sets the flywheel in a uniformly accelerated motion.

The time needed to roll down is measured and compared to the times for other weights.

The mass moment of inertia of the flywheel is calculated from the measured time, the mass of the flywheel and the acceleration distance.

The experimental unit is designed to be fixed to a wall.



Visit our website

On our website you will find all you need to know,
including all the latest news.

GL 210

Dynamic behaviour of multistage spur gears



Learning objectives/experiments

- determining the angular acceleration on gears
- determining the mass moment of inertia of the gear
- determining the friction
- determining the gear efficiency

Inductive speed sensors on all drive gears allow the speeds to be measured. The measured values are transmitted directly to a PC via USB. The data acquisition software is included. The angular acceleration can be read from the diagrams.

Description

- single-stage, two-stage or three-stage spur gear with distributed rotational inertia
- drive via cable drum and variable set of weights
- inductive speed sensors on all shafts

Gears are employed as a link between driving machine and driven machine. They are used to vary torque and speed and to change direction. The aim of dynamic gear analysis is an understanding of the motion sequences and the influence of inertia.

The GL 210 unit is used to study the dynamic behaviour in single-stage, two-stage and three-stage spur gears during transient operation.

The trainer includes four parallel shafts, three drive wheels and three drive gears. Coupling pins can be used to couple the shafts such that different gear stages can be realised. A flywheel may be attached to each shaft in order to increase the rotational inertia. The gear is accelerated via a cable drum and a variable set of weights. The set of weights is raised via a crank. A ratchet prevents the weight from accidentally escaping. A clamping roller freewheel enables free further rotation after the weight has been released. A hand brake allows smooth deceleration. The transparent protective cover with safety lock prevents accidental contact with the rotating parts.

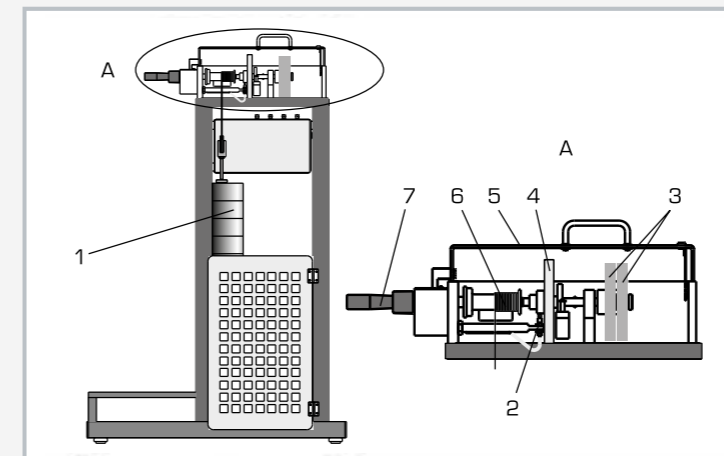

1 set of weights, 2 speed sensor, 3 flywheels, 4 drivegear, 5 protective cover, 6 cable drum, 7 hand crank

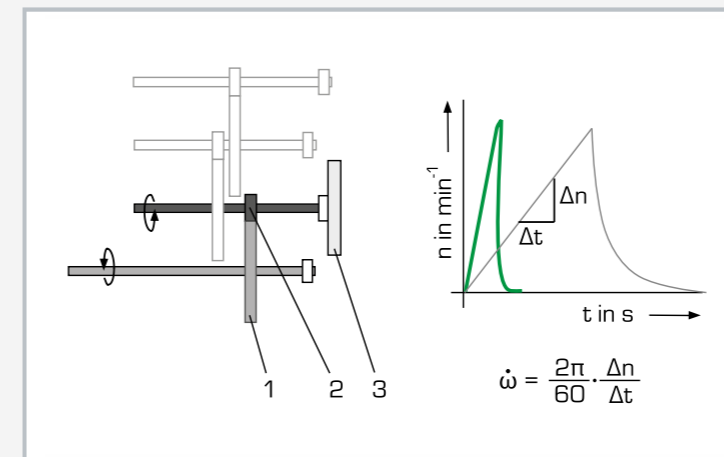

Determining the angular acceleration: 1 driving gear, 2 driven gear, 3 flywheel; speed-time diagram: determining the angular acceleration from the gradient of the curve, green curve for 1-stage gear

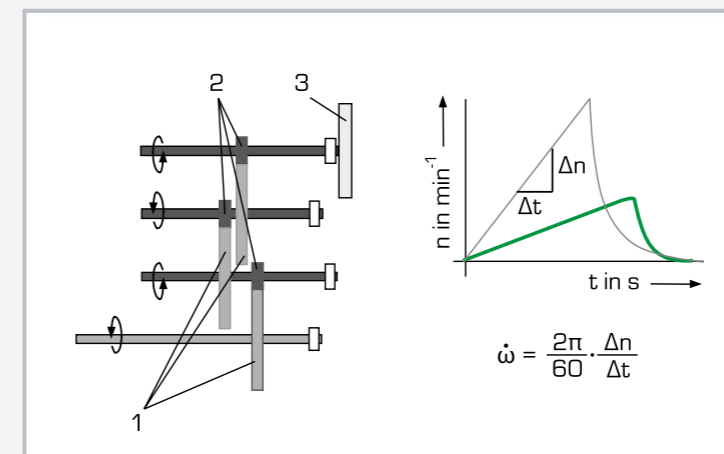

Determining the angular acceleration: 1 driving gears, 2 driven gears, 3 flywheel; speed-time diagram: determining the angular acceleration from the gradient of the curve

Specification

- [1] investigation of the dynamic behaviour of 1-stage, 2-stage or 3-stage spur gears
- [2] 4 shafts, 3 drive wheels and 3 drivegears
- [3] shafts can be coupled by coupling pins
- [4] optional attachable flywheels to increase the rotational inertia on each shaft
- [5] gear is accelerated via cable drum and variable set of weights
- [6] weight raised by hand crank; ratchet prevents accidental release
- [7] clamping roller freewheel enables free further rotation after the weight has been released
- [8] gear decelerated via hand-operated brake
- [9] transparent protective cover with safety lock and protective grill for the set of weights
- [10] inductive speed sensors on all drivegears
- [11] GUNT software for data acquisition via USB under Windows 7, 8.1, 10

Technical data

3-stage gear with 4 shafts

- transmission ratio per stage: $i = 4:1$
- overall transmission ratio: $i = 64:1$

Gear width: 16mm, module 2mm

Drive

- set of weights: 5...50kg
- drop height: max. 0,65m
- max. potential energy: 320Nm

Measuring ranges

- speed: 0...2000min⁻¹

230V, 50Hz, 1 phase
230V, 60Hz, 1 phase; 120V, 60Hz, 1 phase
UL/CSA optional
LxWxH: 970x760x1550mm
Weight: approx. 155kg

Required for operation

PC with Windows

Scope of delivery

- 1 trainer
- 1 set of weights
- 1 GUNT software CD + USB cable
- 1 set of instructional material

GL 212**Dynamic behaviour of multistage planetary gears**

The illustration shows a similar unit.

Learning objectives/experiments

- determine the transmission ratio for a locked gear
- measure transmitted forces for a locked gear
- gear acceleration under constant driving torque
- influence of the transmission ratio
- determine reduced mass moment of inertia
- conversion of potential energy into kinetic energy
- determine friction
- determine gear efficiency

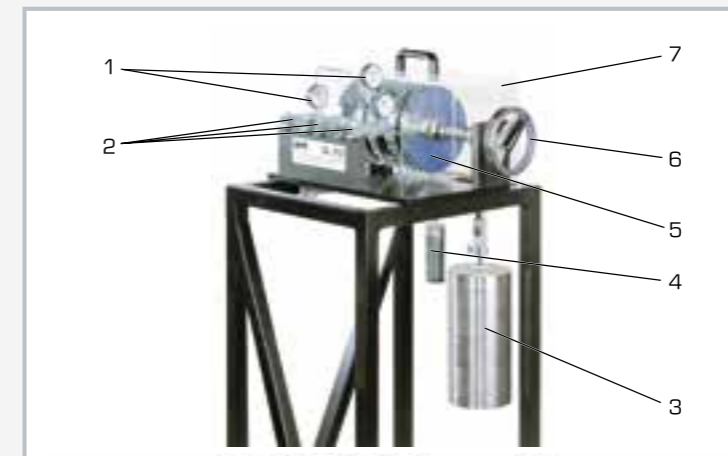

1 dial gauge, 2 bending beam, 3 set of weights, 4 set of weights for measuring transmission ratios, 5 planetary gear, 6 hand crank, 7 protective cover

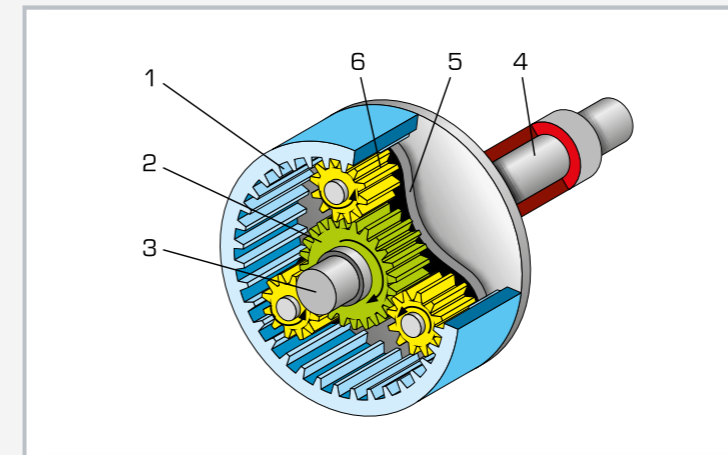

Layout of a planetary gear: 1 ring gear, 2 sun gear, 3 sun gear shaft, 4 planet carrier, 5 planet carrier, 6 planet gear

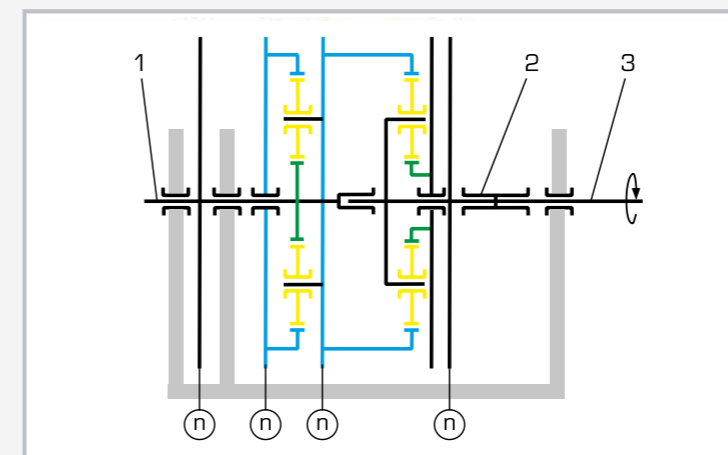

Principle of operation of a 2-stage planetary gear: 1 output shaft, 2 cable drum, 3 drive shaft, green: sun gears, yellow: planet gears, blue: ring gears, n speed

Specification

- [1] investigation of the dynamic behaviour of a 2-stage planetary gear
- [2] three planet gears per stage
- [3] four different transmission ratios possible
- [4] gear is accelerated via cable drum and variable set of weights
- [5] weight raised by hand crank; ratchet prevents accidental release
- [6] clamping roller freewheel enables free further rotation after the weight has been released
- [7] shock absorber for weight
- [8] transparent protective cover
- [9] force measurement on different gear stages via 3 bending bars, display via dial gauges
- [10] inductive speed sensors
- [11] GUNT software for data acquisition via USB under Windows 7, 8.1, 10

Technical data**2-stage planetary gear**

- module: 2mm
- sun gears: 24-tooth, d-pitch circle: 48mm
- planet gears: 24-tooth, d-pitch circle: 48mm
- ring gears: 72-tooth, d-pitch circle: 144mm

Drive

- set of weights: 5...50kg
- max. potential energy: 245,3Nm

Load at standstill

- weight forces: 5...70N

Measuring ranges

- speed: 0...2000min⁻¹

230V, 50Hz, 1 phase
230V, 60Hz, 1 phase; 120V, 60Hz, 1 phase
UL/CSA optional
LxWxH: 950x600x1700mm
Weight: approx. 150kg

Required for operation

PC with Windows

Scope of delivery

- 1 trainer
- 2 sets of weights
- 1 GUNT software CD + USB cable
- 1 set of instructional material

Description

- **two-stage planetary gears with three planet gears each**
- **four different transmissions can be configured**
- **bending beams to measure force**
- **inductive speed sensors for speed-time diagrams to determine the angular acceleration**

The planetary gear is a special type of gear drive, in which the multiple planet gears revolve around a centrally arranged sun gear. The planet gears are mounted on a planet carrier and engage positively in an internally toothed ring gear. Torque and power are distributed among several planet gears. Sun gear, planet carrier and ring gear may either be driving, driven or fixed. Planetary gears are used in automotive construction and shipbuilding, as well as for stationary use in turbines and general mechanical engineering.

The GL 212 unit allows the investigation of the dynamic behaviour of a two-stage planetary gear. The trainer consists of two planet gear sets, each with three planet gears. The ring gear of the first stage is coupled to the planet carrier of the second stage. By fixing individual gears, it is possible to configure a total of four different transmission ratios. The gear is accelerated via a cable drum and a variable set of weights. The set of weights is raised via a crank. A ratchet prevents the weight from accidentally escaping. A clamping roller freewheel enables free further rotation after the weight has been released. The weight is caught by a shock absorber. A transparent protective cover prevents accidental contact with the rotating parts.

To be able to determine the effective torques, the force measurement measures the deflection of bending beams. Inductive speed sensors on all drive gears allow the speeds to be measured. The measured values are transmitted directly to a PC via USB. The data acquisition software is included. The angular acceleration can be read from the diagrams. Effective mass moments of inertia are determined by the angular acceleration.

TM 600

Centrifugal force



Description

■ laws of the behaviour of rotating masses

Centrifugal force occurs in the motion of a rigid body on an orbit and is the inertia force, which acts with a direction away from the centre of rotation. The counter force associated with the inertial force is the centripetal force. Both forces are of equal magnitude and opposite in direction. Centrifugal forces occur in all rotating machinery such as turbines and must be controlled to prevent damage to machine elements.

The TM 600 unit can be used to study centrifugal forces under various conditions. The core of the experimental unit is a rotating arm on a vertical rotation axis. Different masses are attached to the arm. The orbital radius can be set via the position of the mass on the arm. There are three different masses available. The occurring centrifugal force is transferred from the arm to a bending beam. The force-proportional deformation is detected via an electronic measuring system and displayed digitally.

The speed, also displayed digitally, of the controlled drive motor can be continuously adjusted. A transparent protective cover above the rotating arm ensures safety: operation is only possible when the protective cover is properly attached.

Learning objectives/experiments

- investigation of the centrifugal force as a function of
 - ▶ the speed
 - ▶ the size of the rotating mass
 - ▶ the rotation radius

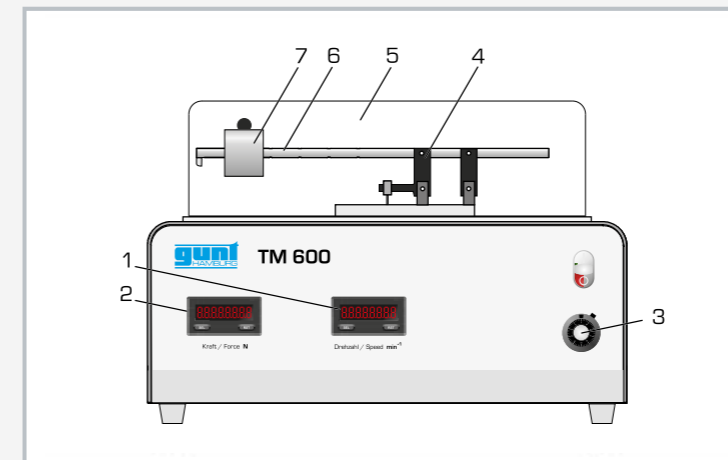

1 centrifugal force display, 2 speed display, 3 adjustment of the speed, 4 connecting rod (force measurement), 5 protective cover, 6 rotating arm, 7 mass

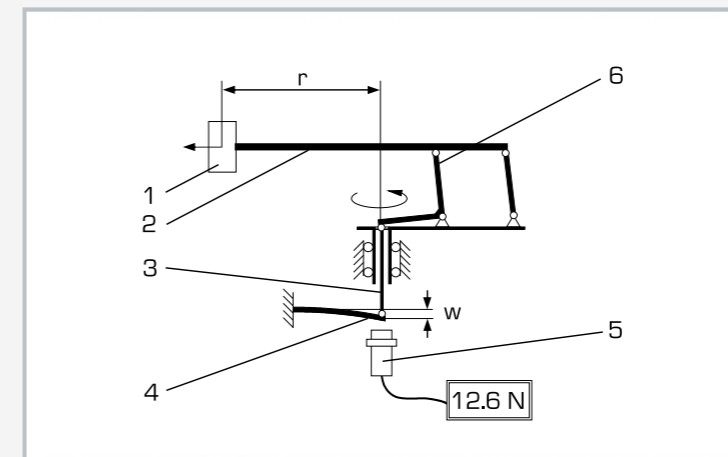

Principle of force measurement with force-proportional deformation:
1 mass, 2 rotating arm, 3 member, 4 bending beam, 5 position sensor, 6 member;
r radius, w deformation

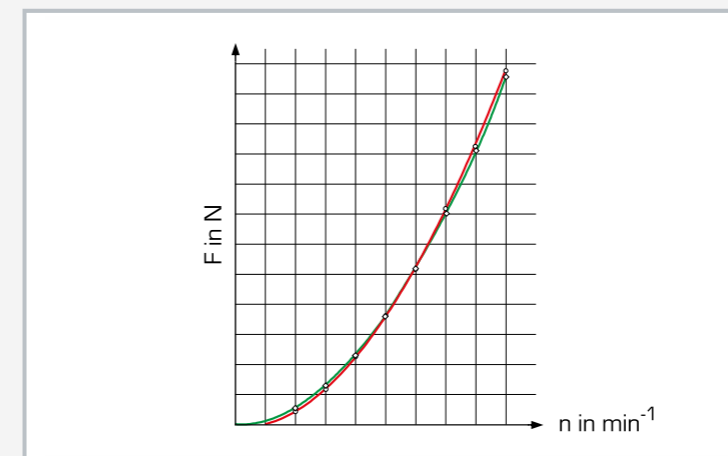

Dependence of centrifugal force on the speed green: calculated values, red: measured values; F centrifugal force, n speed

Specification

- [1] measure the centrifugal force on rotating masses
- [2] adjustment of the orbital radii
- [3] selection of different masses
- [4] continuous adjustment of the speed
- [5] drive with DC motor
- [6] transmission of centrifugal force via the connecting rod and member to a bending beam
- [7] force-proportional deformation of the bending beam
- [8] measure the centrifugal force via an inductive position sensor on the bending beam
- [9] digital display of force and speed
- [10] protective cover with electronic coupling to the drive ensures safe operation

Technical data

Orbit

- orbital radii: 25mm, 50mm, 75mm, 100mm, 125mm
- max. velocity: 6,5m/s

Masses: 50g, 75g, 100g

Drive motor

- max. power: 35W
- max. speed: 6000min⁻¹

Measuring ranges

- speed: 0...500min⁻¹
- force: 0...25N, resolution: 0,1N

230V, 50Hz, 1 phase
230V, 60Hz, 1 phase; 120V, 60Hz, 1 phase
UL/CSA optional
LxWxH: 420x400x270mm
Weight: approx. 23kg

Scope of delivery

- 1 experimental unit
- 1 set of tools
- 1 set of weights
- 1 set of instructional material

TM 630
Gyroscope**Description**

- properties of a guided gyro
- effect of precession

A gyroscope is used in aviation and the aerospace industry to stabilise the position or as a navigation tool in so-called inertial navigation. The basic element of a mechanical spinning top is a rapidly rotating mass. A free spinning top is desired, which maintains the position of its rotational axis in space independently of gravity. This property is exploited in the artificial horizon in the aircraft. If the spinning top is mounted on a frame, it is referred to as a guided or enclosed gyro. A guided spinning top is the main component of a gyroscope. If a force acts on a guided spinning top perpendicular to the axis of rotation, the spinning top exerts a moment: the gyroscopic moment. The rotation perpendicular to the axis of rotation is known as precession. A gyroscope therefore has three axes: the axis of rotation of the spinning top, the precession axis and the axis of the gyroscopic effect that triggers the gyroscopic moment, which are all perpendicular to each other.

The TM 630 unit enables familiarisation with how a gyroscope works. The moments caused by the precession of the spinning top can be experimentally determined.

The spinning top is composed of a flywheel mass that is driven at high speed by an electric motor. The spinning top is mounted in a cardan frame. The frame can be rotated about the vertical axis by a second electric motor. This generates the precession of the spinning top. By means of the precession, the spinning top exerts a moment – the gyroscopic moment – about the horizontal axis. The gyroscopic moment causes deflection of the inner frame. The gyroscopic moment can be determined with a lever and a sliding weight.

The speeds of both electric motors for rotation and precession can be adjusted and are displayed digitally.

A transparent protective cover above the rotating arm ensures safety: operation is only possible when the protective cover is properly attached.

Learning objectives/experiments

- experimental verification of the gyroscopic laws
- familiarisation with the three gyro axes
- calculation of gyroscopic moments
- study the effect of precession



1 protective cover, 2 gyro drive motor, 3 speed displays and adjustment for of the horizontal gyro axis and the vertical precession axis, 4 spinning top flywheel mass, 5 lever, 6 sliding weight, 7 inner frame

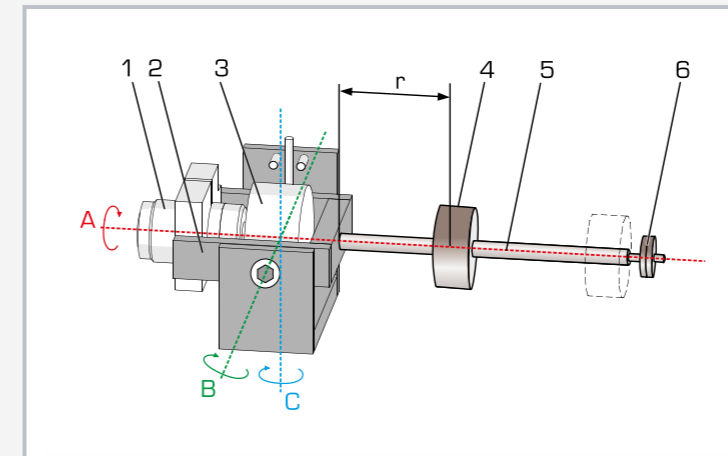

1 drive motor, 2 inner frame, 3 spinning top flywheel mass, 4 sliding weight, 5 lever, 6 fine weights; r distance of the weight, A horizontal axis of the spinning top = axis of rotation, B rotational axis of the inner frame = axis of gyro effect, C vertical axis = precession axis

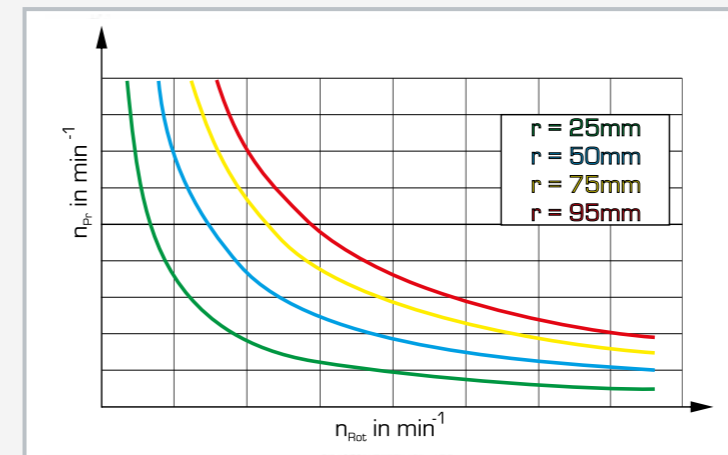

Curve of the precession speed for different gyroscopic moments n_{pr} , speed of the precession axis, n_{rot} speed of the rotational axis, r distance of the sliding weight (gives gyroscopic moment)

Specification

- [1] familiarisation with a gyroscope
- [2] investigate a guided spinning top
- [3] adjustment of the speed along the rotation axis
- [4] adjustment of the speed along the precession axis
- [5] determine the gyroscopic moment
- [6] digital display of speeds along the rotation axis and the precession axis
- [7] protective cover with release for the drive ensures safe operation

Technical data**Gyro**

- drive motor power: 3,6W
- moment of inertia of the spinning top: 375gcm^2
- speed of the rotation axis: $1000\text{...}6000\text{min}^{-1}$
- gyroscopic moment: $0\text{...}61\text{Nm}$

Precession

- drive motor power: 19W
- speed of precession axis: $5\text{...}63\text{min}^{-1}$

230V, 50Hz, 1 phase
230V, 60Hz, 1 phase; 120V, 60Hz, 1 phase
UL/CSA optional
LxWxH: 420x400x310mm
Weight: approx. 22kg

Scope of delivery

- 1 experimental unit
- 1 set of tools
- 1 set of instructional material

TM 605
Coriolis force**Description**

- visualisation of the Coriolis force effect
- rotating reference system
- water jet as moving mass

When a mass moves relative to the reference system within a rotating reference system, this movement is deflected. This deflection is caused by the Coriolis force, an apparent or inertial force. The Coriolis force plays a crucial role in meteorology and physical oceanography, since it influences the course of air and water currents due to the Earth's rotation.

In engineering, the Coriolis force occurs when a rotational motion interferes with a further movement of the same object. This can occur for example in cranes, gearboxes or robots.

The TM 605 experimental unit is designed to clearly demonstrate the effect of the Coriolis force in a rotating reference system. A transparent water tank with submersible pump is placed on a rotatable arm and then rotated. Within the rotating reference system, the pump produces a water jet in a radial direction. Depending on the flow rate of the pump or the water velocity, as well as speed and direction of rotation, the water jet is visibly deflected due to the Coriolis force. The degree of deflection can be determined by means of a scale on the water tank. The speed is continuously adjustable, electronically controlled and digitally displayed.

Learning objectives/experiments

- inertial or apparent force
- interference of a rotational movement on a translational movement
- visualisation of the Coriolis force effect



1 pump, 2 water tank, 3 speed display, 4 switch for direction of rotation, 5 speed adjustment, 6 rotating arm, 7 water jet

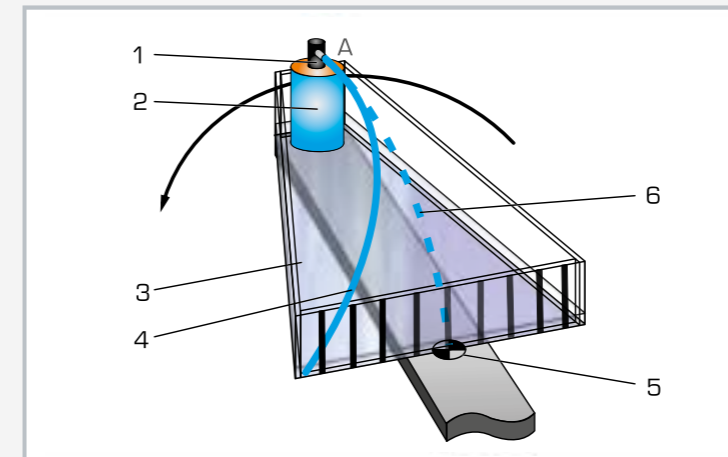

1 nozzle for water jet, 2 pump, 3 tank, 4 deflected water jet, 5 pivot point of the arm, 6 water jet with a stationary arm, 7 direction of rotation; A starting point of the moving mass

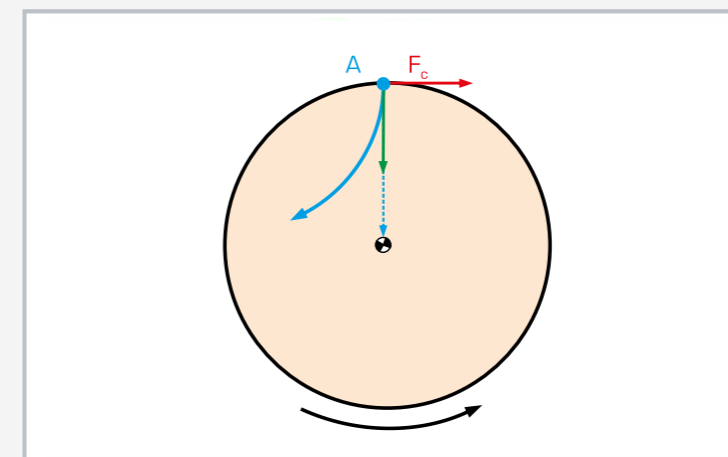

Effect of the Coriolis force: A starting point of the moving mass, F_c Coriolis force; orange: rotating reference frame, red: direction of the Coriolis force, green: current motion of the mass, dashed blue: direction of movement without rotation, blue: actual direction of movement with rotation

Specification

- [1] visualisation of the Coriolis force effect
- [2] rotating reference frame consisting of transparent water tank with submersible pump on a rotating arm
- [3] deflection of a water jet in radial direction dependent on the speed and direction of rotation
- [4] scale to read the deflection of the water jet
- [5] closed water circuit
- [6] speed sensor with digital display

Technical data**Rotating arm**

- continuously adjustable speed: 0...60min⁻¹
- adjustable direction of rotation

Submersible pump

- flow rate: 10L/min

230V, 50Hz, 1 phase
230V, 60Hz, 1 phase; 120V, 60Hz, 1 phase
UL/CSA optional
LxWxH: 420x400x320mm
Weight: approx. 25kg

Scope of delivery

- 1 experimental unit
- 1 set of tools
- 1 set of instructional material

TM 632 Centrifugal governor



Description

- visualisation of the effect of centrifugal force
- how various centrifugal systems work
- determination of characteristic curves and setting curves of different centrifugal governors

Centrifugal governors use the properties of centrifugal force to control the speed of a machine. Due to centrifugal force, a rotating flyweight mass has the tendency to move away from the axis of rotation and is prevented by counteracting mechanisms. These mechanisms are differentiated into those governors that use weights and those that use springs. Corresponding kinematics cause a deflection proportional to the speed to occur on the governor. Via an actuator, this affects the energy supplied to the machine, thereby controlling the machine's speed.

The TM 632 experimental unit presents centrifugal systems that demonstrate the different principles of operation of both weight and spring-based governors.

The housing holds the drive with an electronically controlled motor. The speed is continuously adjustable and displayed digitally. The governors are inserted into a chuck on the drive. Centrifugal masses, sleeve forces and spring preload can be varied using the accessories supplied, depending on the governor. The stroke can be read on markings on the governor shaft. A transparent protective cover above the rotating centrifugal governor ensures safety: operation is only possible when the protective cover is properly attached.

Learning objectives/experiments

- kinetics and kinematics of the following centrifugal systems
 - ▶ Porter governor
 - ▶ Proell governor
 - ▶ Hartnell governor
- adjustment of centrifugal governors
- recording the governor characteristic curves and setting curves
- calculation of the structural design and adjustment of different governors

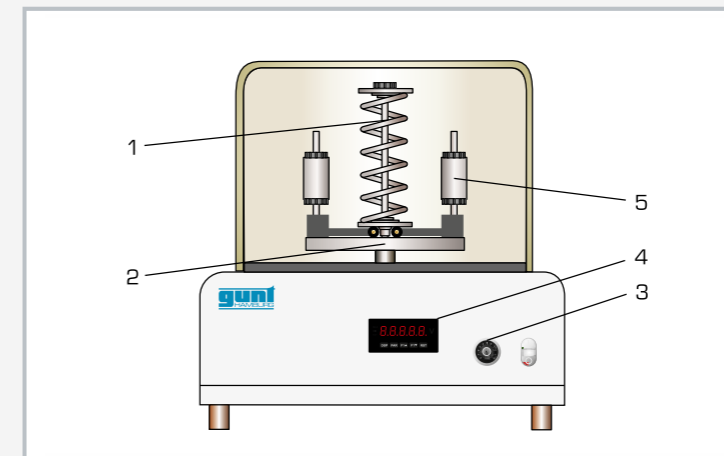

1 spring, 2 Hartnell governor centrifugal system, 3 control element for adjusting speed, 4 speed display, 5 centrifugal mass

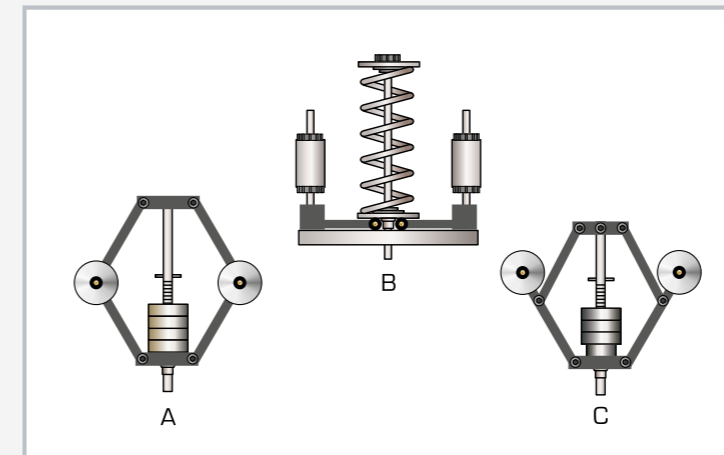

Different centrifugal systems: A Porter governor, B Hartnell governor, C Proell governor

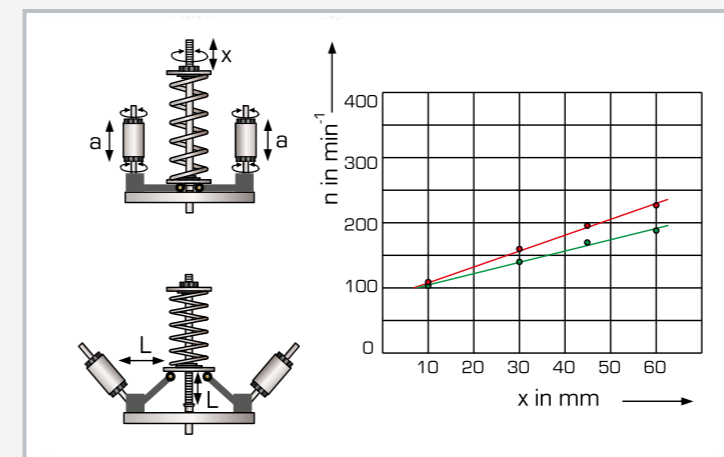

Settings and characteristic of the Hartnell governor at constant centrifugal force lever arm: a centrifugal mass adjustment, L centrifugal force lever arm, n speed, x spring preload; green increasing speed, red decreasing speed

Specification

- [1] how centrifugal systems work
- [2] three different centrifugal governors: Porter, Proell and Hartnell governors
- [3] versatile range of variations on the governors: adjustment of the centrifugal mass, the sleeve force and the spring preload
- [4] continuous adjustment of speed via a potentiometer
- [5] drive with DC motor
- [6] digital speed display
- [7] protective cover with electronic coupling to the drive ensures safe operation

Technical data

DC motor

- max. power: 35W
- Speed control: 60...400min⁻¹

Proell governor

- sleeve mass: 3x 100g
- centrifugal mass: 2x 150g

Porter governor

- sleeve mass: 3x 100g
- centrifugal mass: 2x 400g

Hartnell governor

- centrifugal mass: 2x 400g
- 2 compression springs, adjustable spring preload

Measuring ranges

- speed: 0...600min⁻¹

230V, 50Hz, 1 phase

230V, 60Hz, 1 phase; 120V, 60Hz, 1 phase

UL/CSA optional

LxWxH: 420x420x430mm

Weight: approx. 30kg

Scope of delivery

- 1 experimental unit
- 3 centrifugal governors
- 1 set of tools
- 1 set of weights
- 1 set of instructional material

Basic knowledge Vibrations

Vibration is the process occurring when a physical quantity periodically changes depending on time. This is associated with a conversion of energy from one form to another.

In the case of mechanical vibrations, periodic potential energy is converted into kinetic energy and the reverse. Every mechanical vibration is an unevenly accelerated motion. It arises due to the addition of energy to a vibratory system, e.g. a pendulum, which has force applied to it.

When the system continues to vibrate with a constant amplitude, the vibration is referred to as **undamped** motion. Without further addition of energy, each vibration is damped more or less strongly, i.e. its amplitude decreases. If the course of the vibration can be described by a sinusoidal function, we call the vibration a **harmonic** motion.

Characteristic variables of a vibration

Characteristic variable	Formula (symbol)	Technical description
Elongation	$y = y(t)$	Momentary distance of the vibrating body from the rest or equilibrium position
Amplitude	\hat{y} oder y_m	Maximum value of elongation
Frequency	$f = 1/t$	Number of vibrations per unit of time t
Vibration period	$T = 1/f$	Duration of a complete vibration
Angular frequency	$\omega = 2 \cdot \pi \cdot f$	Angular velocity of a circular motion, whose projection results in a harmonic oscillation, indicates the exceeded phase angle of the vibration per time period
Phase angle	$\phi = \omega \cdot t + \phi_0$	Indicates the current state of a harmonically oscillating system or a shaft (either degrees or radians); a vibration period is equal to a phase angle of 2π
Zero phase angle (phase constant)	ϕ_0	Phase angle at time $t = 0$
Restoring force	F_R	Force that constantly pulls the vibrating body back to its rest position, which is opposite to the elongation direction
Empirical value	k	The proportionality factor between restoring force and elongation in elastic vibrations is identical to the spring stiffness
Natural frequency		Frequency at which the system oscillates in the natural mode after a single excitation
Damping		Removal of the amplitude in the course of a vibration

Undamped harmonic motion

The characteristic variables of an undamped harmonic motion are illustrated in the diagram using the example of a spring pendulum. The velocity is calculated via the first derivative, the acceleration using the second derivative:

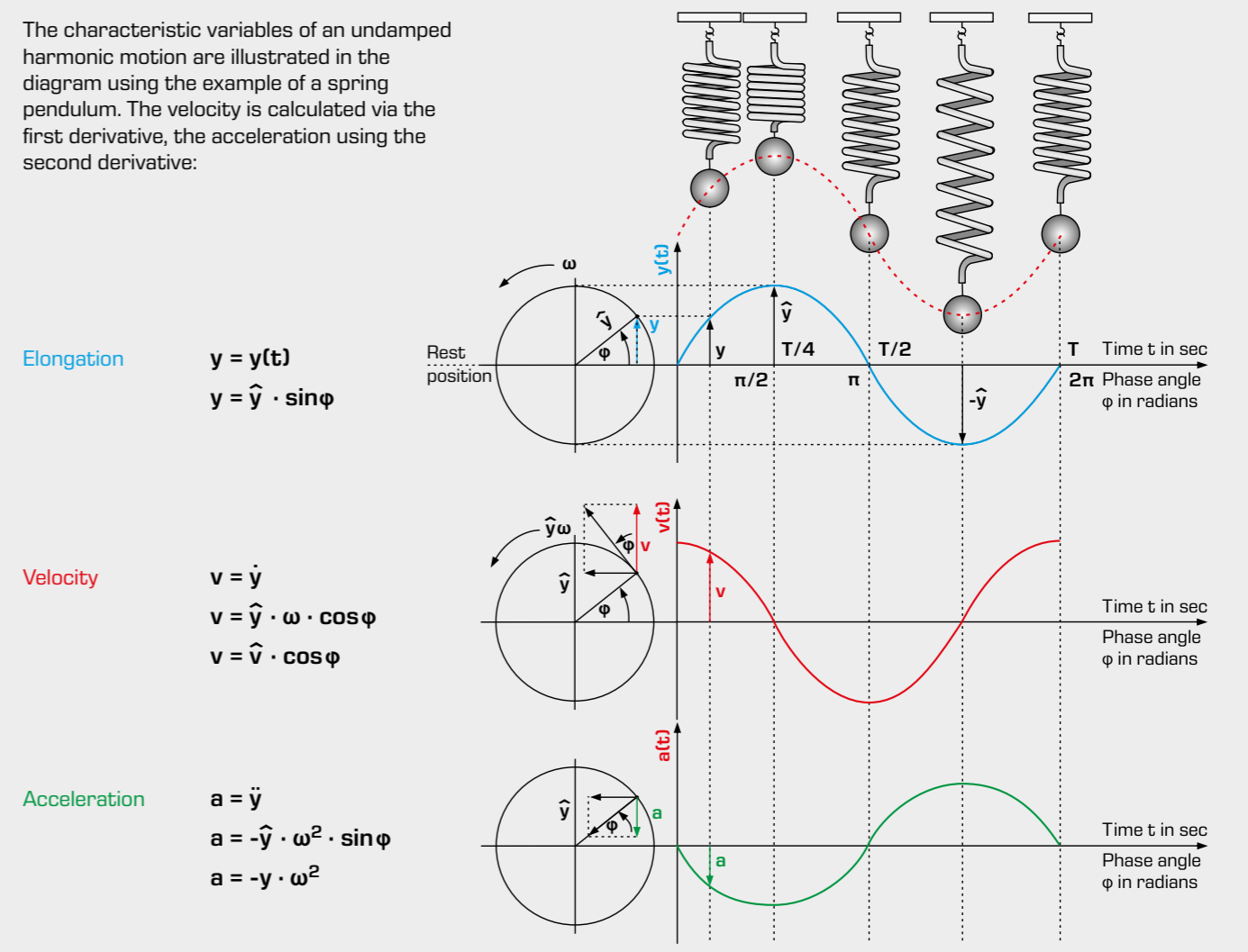

Torsional vibration

In torsional vibration, a rotatably mounted solid body vibrates around one of its axes (rotary degree of freedom), as opposed to translational vibration. The terms "torsional" and "rotary" are synonymously used. We talk about torsional vibration when referring to a shaft twisting during a process (warping).

Every torsional vibration is made possible by a restoring moment, which is proportional to the angle of rotation at any time, but in the opposite direction.

The linear vibration laws also apply to torsional vibrations.

Elongation	y	$\hat{=}$	Angle of rotation	$\epsilon = \hat{\epsilon} \cdot \sin \phi$
Velocity	$v = \dot{y}$	$\hat{=}$	Angular velocity	$\dot{\epsilon} = \hat{\epsilon} \cdot \omega \cdot \cos \phi$
Acceleration	$a = \ddot{y}$	$\hat{=}$	Angular acceleration	$\ddot{\epsilon} = \hat{\epsilon} \cdot \omega^2 \cdot \sin \phi$

TM 161

Rod and gravity pendulum



Description

■ investigation of pendulum swings ■ comparing physical and mathematical pendulums

Pendulums perform oscillations. Gravity produces the restoring moment. We distinguish between mathematical and physical pendulums. A mathematical pendulum describes an idealised gravity pendulum. In physical pendulums, the shape and size of the pendulum body is taken into account. Both are theoretical models for the description of a real pendulum.

The TM 161 unit is used to study pendulum swings. A gravity pendulum (mathematical pendulum) and a rod pendulum (as a physical pendulum) are compared to each other. The unit contains a metal rod with a movable auxiliary mass as the rod pendulum. The suspension point can be adjusted on the knife-edge bearing of the pendulum. The length of the gravity pendulum can be easily changed using a clamping device.

The experimental unit is designed to be fixed to a wall.

Learning objectives/experiments

- oscillation period of gravity and rod pendulum
- determine centre of gravity on the rod pendulum
- reduced pendulum length and centre of inertia of the rod pendulum

Specification

- [1] experiments on pendulum swings, comparison of physical and mathematical pendulums
- [2] rod pendulum as physical pendulum, made of metal and mounted on knife-edge bearing
- [3] knife-edge bearing mounted to slide on the rod to effectively vary the pendulum length
- [4] weight for the rod pendulum, sliding gravity pendulum as a mathematical pendulum
- [5] adjustable length of the gravity pendulum
- [7] stopwatch to measure the oscillation period
- [8] bracket for wall mounting

Technical data

- Gravity pendulum
- length: up to 2000mm
 - nylon rope
 - weight
 - ▶ diameter: 50mm
 - ▶ mass: 0,52kg

Rod pendulum

- length: 1000mm
- diameter: 8mm
- mass: 0,39kg
- pendulum weight
 - ▶ diameter: 50mm
 - ▶ mass: 0,49kg

Stopwatch: 1/100s

LxWxH: 250x80x2000mm
Weight: approx. 5kg

Scope of delivery

- 1 experimental unit
- 1 set of instructional material

TM 162

Bifilar/trifilar suspension of pendulums



Description

■ ideal mathematical pendulum can be demonstrated ■ moment of inertia in an experiment on a rotary pendulum

In a bifilar suspension, the pendulum body is suspended over two threads. The pendulum body oscillates in a plane purely translationally without rotation. This kind of pendulum can be considered as a mathematical pendulum. In a trifilar suspension with three threads, the pendulum body is set in a torsional vibration. The torsional vibration can be used to determine the moment of inertia by experiment.

The TM 162 unit can be used to study pendulum swings with bifilar or trifilar suspension. A beam, a cylinder or a circular ring are used as pendulum bodies. The length of the threads can be adjusted using clamping devices. The moments of inertia of the pendulum body can be calculated from the measured oscillation period. The oscillation period can be varied by changing the thread length.

The experimental unit is designed to be fixed to a wall.

Learning objectives/experiments

- influence of thread length on the oscillation period
- determine the mass moment of inertia

Specification

- [1] investigation of the vibration behaviour of various pendulum bodies in bifilar and trifilar suspension
- [2] investigation of a mathematical pendulum (bifilar) and a physical pendulum (trifilar)
- [3] choice of three pendulum bodies: beam, cylinder, circular ring
- [4] change the thread length with a clamping device
- [5] stopwatch to measure the oscillation period
- [6] determine the mass moment of inertia
- [7] bracket for wall mounting

Technical data

Pendulum bodies

- beam
 - ▶ LxWxH: 40x40x160mm
 - ▶ mass: 2kg
- cylinder
 - ▶ diameter: 160mm
 - ▶ height: 19mm
 - ▶ mass: 3kg
- circular ring
 - ▶ outer diameter: 160mm
 - ▶ inner diameter: 100mm
 - ▶ height: 41mm
 - ▶ mass: 4kg

Thread length: up to 2000mm

Stopwatch: 1/100s

LxWxH: 205x200x2000mm
Weight: approx. 12kg

Scope of delivery

- 1 experimental unit
- 1 set of instructional material

TM 163

Torsional vibrations



Description

■ vibrations of different torsion bars

In torsional vibrations, a restoring moment is produced by the twisting of a bar in the oscillating system. The restoring moment strives to return the rotating mass to the resting position.

The TM 163 unit can be used to study torsional vibration on torsion bars with different diameters and different lengths. At the top end, the torsion bars are clamped in a quick-action chuck.

A solid circular disk or a circular ring is fixed at the bottom end of the bar using a quick-action chuck. They have the same mass and the same diameter, but different moments of inertia due to their shape.

The torsion bars can be quickly and easily exchanged and their length varied. The oscillation period is measured.

The experimental unit is designed to be fixed to a wall.

Learning objectives/experiments

- determine the oscillation period as a function of
 - ▶ the length of the torsion bar
 - ▶ the diameter of the torsion bar
 - ▶ the rotating mass and its shape

Specification

- [1] torsional vibrations on different torsion bars
- [2] 5 aluminium torsion bars with different diameters
- [3] adjustable effective length of the torsion bars
- [4] quick-action chucks to swap components
- [5] generate torsional vibration via a circular disk or circular ring
- [6] stopwatch to measure the oscillation period
- [7] bracket for wall mounting

Technical data

- Five torsion bars
- aluminium
 - length: 1100mm
 - diameter: 2mm, 3mm, 4mm, 5mm, 6mm

- Circular ring
- outer diameter: 160mm
 - inner diameter: 100mm
 - height: 31mm
 - moment of inertia: 0,01335kgm²

- Circular disk
- diameter: 160mm
 - height: 19mm
 - moment of inertia: 0,0096kgm²

Stopwatch: 1/100s

LxWxH: 700x200x200mm
Weight: approx. 12kg

Scope of delivery

- 1 experimental unit
- 1 set of instructional material

TM 164

Coil spring vibrations



Description

■ torsional oscillations of a spring-mass system

In helical springs, the spring force is generated by the elastic deformation of a metal band wound in an Archimedean spiral. If a mass is attached to the spring, we refer to it as a spring-mass system. The resistance that the spring presents opposite of the elastic deformation is known as spring stiffness. It is a characteristic variable of the spring.

The TM 164 unit comprises a helical spring connected to a rotating lever. Masses can be attached to the lever at various distances. This creates a spring-mass system, which can be used to study the effects of the spring stiffness, mass and mass distribution on the oscillation frequency. The deflection angle can be read on an angle scale.

The experimental unit is designed to be fixed to a wall.

Learning objectives/experiments

- determine the rigidity of a helical spring
- determine the natural frequency of a spring-mass system
- investigate the effect of mass and mass distribution

Specification

- [1] investigate vibrations on a spring-mass system
- [2] lever with sliding mass to deflect the helical spring
- [3] adjustable distance of the mass to the rotation axis
- [4] angle scale for reading the angle of deflection
- [5] stopwatch to measure the oscillation period
- [6] determine the natural frequency and the spring stiffness
- [7] bracket for wall mounting

Technical data

- Helical spring
- cross-section: 10x1mm
 - spring length: approx. 800mm
 - inner radius: 10mm
 - outer radius: 50mm
 - winding distance: 8,5mm

Sliding mass: 2x 0,5kg

Distance from mass to rotation axis

- 36...150mm

Deflection angle

- max. 360°
- graduation: 1°

Stopwatch: 1/100s

LxWxH: 250x200x360mm
Weight: approx. 6kg

Scope of delivery

- 1 experimental unit
- 1 set of instructional material

TM 150 Vibration trainer

Vibration theory requires a good understanding of mathematical and physical relations. In technical professions, knowledge of vibration theory is essential. Illustrative experiments are offered to make it easier for students to understand the principles.

The TM 150 vibration trainer developed especially for this demanding field allows conducting experiments on a variety of vibration-related topics.

- pendulum swings
- spring-mass systems
- free and forced vibration
- damped vibrations
- beam vibrations
- dual-mass systems and dynamic vibration absorbing effects

TM 150 Vibration trainer



To study **pendulums**, the trainer includes different pendulum versions and a pendulum bearing:

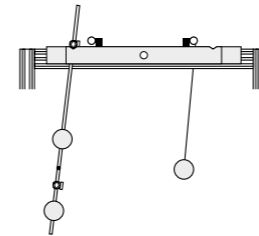

- 2 gravity pendulums with steel and wooden ball
- 2 rod pendulums with adjustable masses and knife-edge bearings

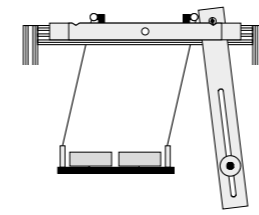

- 1 wooden physical pendulum with adjustable masses and knife-edge bearing
- 1 pendulum with bifilar suspension and different masses

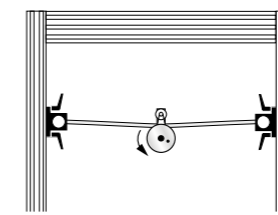

Investigation of **forced vibration** by an imbalance exciter; controllable frequency and imbalance exciter amplitude



Tunable vibration absorber for investigating **vibration-absorbing effects**

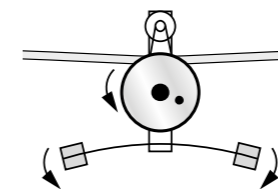

Two bar types available in the **bar-type oscillator**:

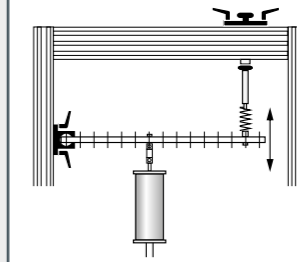

Rigid bar as discrete rotational oscillator, fixed support, suspension on a helical spring. A breadboard allows the attachment of springs, exciters and absorbers in a wide variety of reproducible configurations.

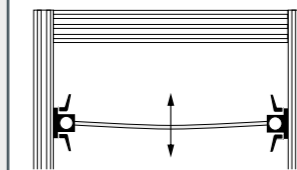

Elastic bar as oscillating continuum, either fixed or movable support, ball-bearing-mounted for minimal system damping

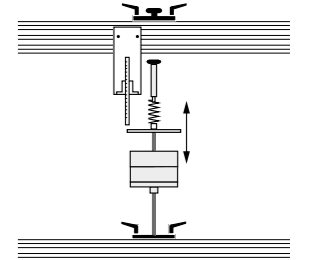

Investigation of a **spring-mass system** with

- height-adjustable spring holder
- bracket for holding different masses
- helical springs with varying spring stiffness
- vernier calliper to measure deflection



Damped vibration via an adjustable viscous damper with very low Coulomb friction

TM150.20 System for data acquisition

- analysis of vibration signals on a PC
- frequency and phase response curves
- all principal functions of a digital storage oscilloscope
- frequency spectra of the signals
- comprising software, a displacement sensor, a reference sensor and an interface box
- the interface box supplies up to three sensors, prepares their measuring signals for the PC and offers them to three analogue outputs for display



Accessories set TM 150.02



Torsional vibrations play a key role in drive systems and must be controlled to avoid damage. The TM 150.02 accessories set can be used to produce **free and damped torsional vibrations** and to study the effects of torsional stiffness, mass and damping on frequency and amplitude.

The range of experiments includes

- torsional stiffness
- mass moment of inertia
- free torsional vibrations
- damped torsional vibrations
- oscillator with several masses



For technical details on the **TM 150.02** unit, please see chapter 4.

All parts of the system are ready at hand and securely housed in a storage system.

TM 150 Vibration trainer



Learning objectives/experiments

- experiments with pendulums
 - ▶ Kater's pendulum
 - ▶ reduced pendulum length
 - ▶ spring-mass system
- bar-type oscillator
 - ▶ undamped oscillation
 - ▶ damped oscillation
 - ▶ forced vibration
- damped and undamped resonance
- absorber effect in multi-mass oscillators

Description

- detailed, wide-ranging series of experiments on the mechanical vibration theory
- experiments on various pendulums, bar-type oscillators and spring-mass systems
- damping, resonance and absorber effects in forced vibrations

Mechanical vibrations are usually found as an unwanted side effect in many areas of engineering. Examples include vehicle vibrations on uneven roads or engine vibrations. Vibration theory is a particularly challenging area in the field of mechanics.

The TM 150 vibration trainer can be used to study many topics from the field of vibration theory through experimentation.

The topics range from simple pendulum-swinging forced vibrations with resonance to vibration absorption.

The central element of the vibration trainer is a sturdy profile frame, to which the different experimental setups are easily attached. The extensive accessories are housed in a mobile laboratory table with drawers. In addition to free vibrations, forced vibrations can also be represented by means of an electric motor imbalance exciter. The excitation frequency is set and displayed on a control unit.

An oil damper allows the study of damped vibrations with adjustable damping ratios. Vibration absorbing is demonstrated with a tuneable bending oscillator. A mechanical drum and a polar chart recorder make it possible to record vibrations.

The measured values can be displayed and analysed on a PC using the optional TM 150.20 unit for data acquisition.

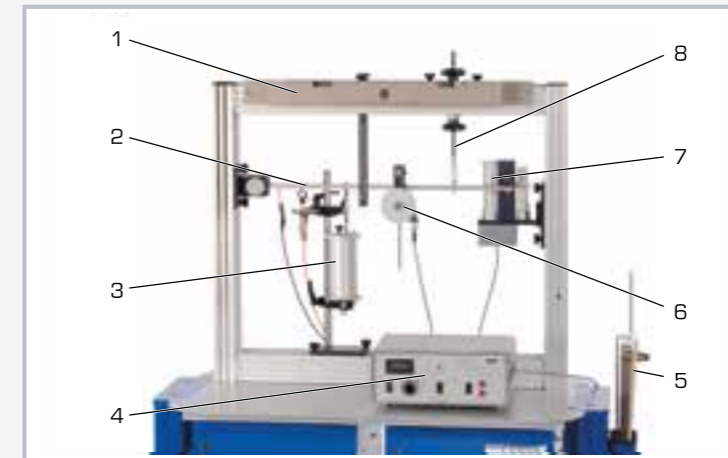

1 pendulum bearing, 2 bar-type oscillator, 3 container for oil damper, 4 control unit for imbalance exciter, 5 storage for additional pendulums, 6 imbalance exciter, 7 drum recorder, 8 spring

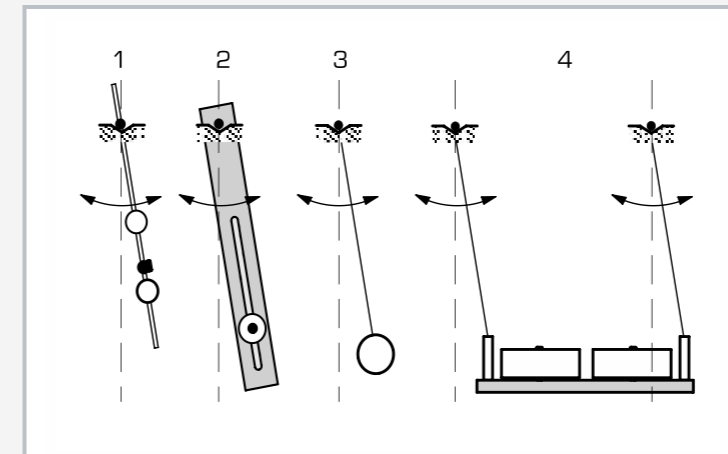

1 rod pendulum, 2 wooden pendulum with adjustable additional mass, 3 gravity pendulum, 4 bifilar suspended gravity pendulum with additional masses

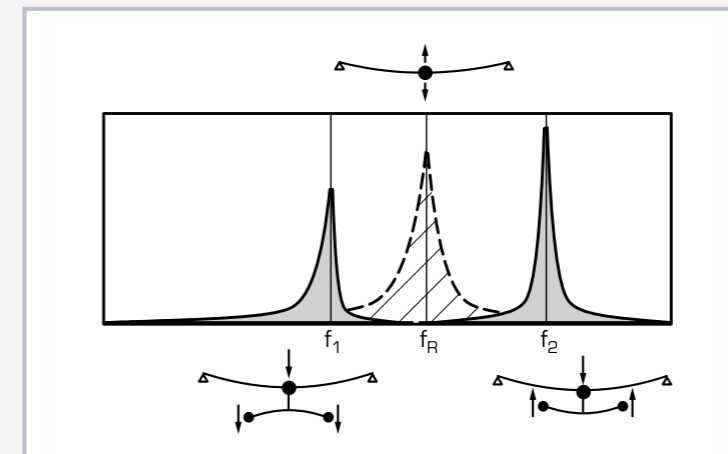

Absorber effect of additional masses:
The shaded area shows the resonance of an undisturbed bar-type oscillator at f_R . The two grey shaded areas at f_1 and f_2 are the new resonances of the system. At f_R , the amplitude of the newly occurring vibration system created by the absorber completely disappears.

Specification

- [1] vibration trainer with experiments on damping, resonance, dual-mass system and vibration absorption
- [2] 6 pendulum oscillators, 2 bar-type oscillators and 1 spring-mass oscillator
- [3] electrical imbalance exciter
- [4] control unit for the imbalance exciter with a digital frequency display and a TTL output for triggering external devices
- [5] tuneable absorber with a leaf spring
- [6] adjustable oil damper
- [7] electrically operated drum recorder for recording free vibrations
- [8] polar chart recorder for determining the amplitude and phase of forced vibrations

Technical data

Beam, rigid: LxWxH: 700x25x12mm, 1,6kg
 Beam, elastic: LxWxH: 700x25x4mm, 0,6kg
 Tension-pressure springs
 ■ 0,75N/mm
 ■ 1,5N/mm
 ■ 3,0N/mm

Imbalance exciter
 ■ 0...50Hz
 ■ 100cmg

Oil damper: 5...15Ns/m

Absorber
 ■ leaf spring: WxH: 20x1,5mm
 ■ total mass: approx. 1,1kg
 ■ tuneable: 5...50Hz

Drum recorder: 20mm/s, width 100mm
 Polar chart recorder: \varnothing 100mm

230V, 50Hz, 1 phase
 230V, 60Hz, 1 phase; 120V, 60Hz, 1 phase
 UL/CSA optional
 LxWxH: 1010x760x1800mm
 Frame opening WxH: 870x650mm
 Weight: approx. 150kg

Scope of delivery

- 1 trainer
- 6 pendulums
- 2 beams
- 3 springs
- 1 control unit for imbalance exciter
- 1 imbalance exciter
- 1 oil damper
- 2 recorders
- 1 set of instructional material

TM 150.20

System for data acquisition

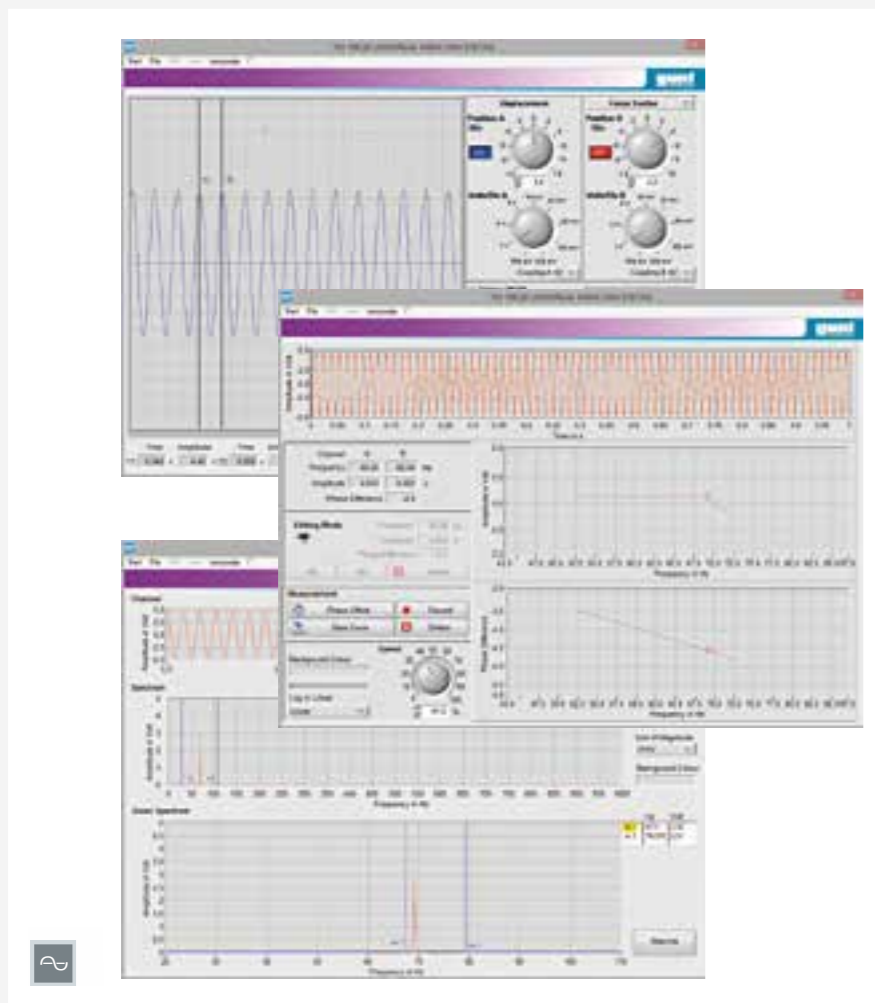

Description

- measurement and illustration of frequency and phase response
- digital storage oscilloscope

This system for data acquisition is an addition to the TM 150 vibration trainer and makes it possible to analyse vibration signals on a PC. Frequency and phase response curves can be easily generated, saved and output using this system. The system also offers all the essential functions of a digital storage oscilloscope and can calculate the frequency spectra of the signals.

In addition to the software, a displacement sensor and a reference sensor, the system also includes an interface box. This supplies up to three sensors, prepares their measuring signals for the PC and offers them to three analogue outputs for display.

All components of the system are ready at hand and securely housed in a storage system.

Learning objectives/experiments

- supported experiments with TM 150
 - ▶ natural vibration of a bar-type oscillator
 - ▶ damped vibration of a bar-type oscillator
 - ▶ forced vibration of a bar-type oscillator (damped and undamped resonance)
 - ▶ frequency and period time measurements
 - ▶ Kater's pendulum

Specification

- [1] data analysis for TM 150
- [2] measurement, recording and analysis of frequency response and transfer function
- [3] functions as a digital storage oscilloscope
- [4] interface box with 3 sensor inputs and 3 analogue outputs
- [5] 1 inductive displacement sensor (amplitude), 1 reference sensor (exciter force)
- [6] GUNT software for data acquisition via USB under Windows 7, 8.1, 10

Technical data

Sensor input channels: 3
Inputs in oscilloscope mode: 2
Time basis: 10...750ms/DIV
Record length: 2000 points
Displacement sensors
 ■ measuring range: 5...10mm
 ■ frequency range: 0...50Hz

230V, 50Hz, 1 phase
230V, 60Hz, 1 phase
120V, 60Hz, 1 phase; UL/CSA optional
LxWxH: 265x260x110mm (interface box)
Weight: approx. 7kg
LxWxH: 600x400x170mm (storage system)

Required for operation

PC with Windows

Scope of delivery

- 1 interface box
- 1 displacement sensor
- 1 reference sensor
- 1 GUNT software CD + USB cable
- 1 set of cables
- 1 storage system
- 1 manual

SE 110.58

Free vibrations in a bending beam



The illustration shows SE 110.58 in a frame similar to SE 112.

Description

- natural frequency on the freely vibrating bending beam
- approximation method according to Rayleigh

An oscillator, which is left alone after a single excitation, performs free vibrations. The frequency of the free vibration is the natural frequency of the oscillator.

In SE 110.58, a bending beam is used as the system's oscillator. The bending beam can be used vertically standing or hanging and in the horizontal position in the SE 112 mounting frame.

The natural frequency is affected by the clamp length and the sliding weights. The bending beam is deflected by hand and performs free, damped vibrations. The resulting amplitudes are measured via strain gauges and a measuring amplifier. The measured values are transmitted directly to a PC via USB, where they can be displayed and the results of the experiments analysed graphically using the software included.

Learning objectives/experiments

- free vibration in a vertical and horizontal bending beam
- determine the natural frequency according to Rayleigh
- how clamping length and mass affect the natural frequency

Specification

- [1] investigation of the free vibration on a bending beam
- [2] elastic bending beam with sliding weights
- [3] bending beam can be mounted on all four sides of the frame
- [4] amplitude measurement via strain gauge and measuring amplifier
- [5] measuring results displayed on a PC
- [6] fixable length scale
- [7] storage system for parts
- [8] GUNT software for data acquisition via USB under Windows 7, 8.1, 10

Technical data

Bending beam
 ■ LxWxH: 635x20x3mm
 ■ material: AlMgSi0,5F22

Weights
 ■ 10x 100g

230V, 50Hz, 1 phase
230V, 60Hz, 1 phase
120V, 60Hz, 1 phase
UL/CSA optional
LxWxH: 720x480x180mm (storage system)
Weight: approx. 14kg (total)

Required for operation

PC with Windows recommended

Scope of delivery

- 1 bending beam
- 1 measuring amplifier
- 1 set of weights
- 1 set of accessories
- 1 storage system with foam inlay
- 1 GUNT software CD + USB cable
- 1 set of instructional material



Machine dynamics

Introduction

Basic knowledge Machine dynamics	184
--	-----

Vibrations in machines

TM 155 Free and forced vibrations	188
TM 150.02 Free and damped torsional vibrations	190
TM 155.20 System for data acquisition	191
TM 140 Free and forced torsional vibrations	192
HM 159.11 Natural vibration on a ship model	194

Rotor dynamics

TM 620 Bending elasticity in rotors	196
TM 625 Elastic shafts	198
TM 620.20 System for data acquisition	200

Balancing

TM 170 Balancing apparatus	202
PT 502 Field balancing	204

Mass forces and mass balance

TM 180 Forces in reciprocating engines	206
GL 112 Investigation of cam mechanisms	208

Vibration isolation

TM 182 Vibrations on machine foundations	210
TM 182.01 Piston compressor for TM182	212

Machinery diagnosis

Overview Machinery diagnosis	214
PT 501 Roller bearing faults	220
Overview PT 500 Machinery diagnostic system	222
PT 500 Machinery diagnostic system, base unit	224
PT 500 Classification Experimentation kits and required / optional components	226
PT 500.01 Laboratory trolley	227
PT 500.04 Computerised vibration analyser	228
PT 500.05 Brake & load unit	230
PT 500.10 Elastic shaft kit	232
PT 500.11 Crack detection in rotating shaft kit	234
PT 500.12 Roller bearing faults kit	236
PT 500.13 Couplings kit	238
PT 500.14 Belt drive kit	240
PT 500.15 Damage to gears kit	242
PT 500.16 Crank mechanism kit	244
PT 500.17 Cavitation in pumps kit	246
PT 500.18 Vibrations in fans kit	248
PT 500.19 Electromechanical vibrations kit	250

Basic knowledge
Machine dynamics



Machine dynamics plays a prominent role in modern mechanical engineering. The requirements of lightweight construction and ever greater power-to-weight ratios make machines particularly susceptible to harmful vibrations. Machine dynamics provides ways and means to address these problems.

What is machine dynamics?

Machine dynamics refers to the study of a system's motion based on the forces acting on the system.

Machine dynamics applies knowledge of engineering mechanics, especially dynamics, to the problems of real machines. The effect of inertia and the occurrence of vibrations play a major role here. Machine dynamics makes it possible to predict the vibrational behaviour of a machine and, where possible, to compensate it. Depending on the task, the vibrations may be desired (shakers, vibrating conveyors) or undesired (engines, turbines).

Methods from vibration measuring technology are used to assess and evaluate vibrations. There are also close links to the fields of engineering design, machine elements and drive systems.

When do vibration problems occur?

Vibration problems may occur if the following two conditions are met:

- periodic excitation forces
- vibratory system

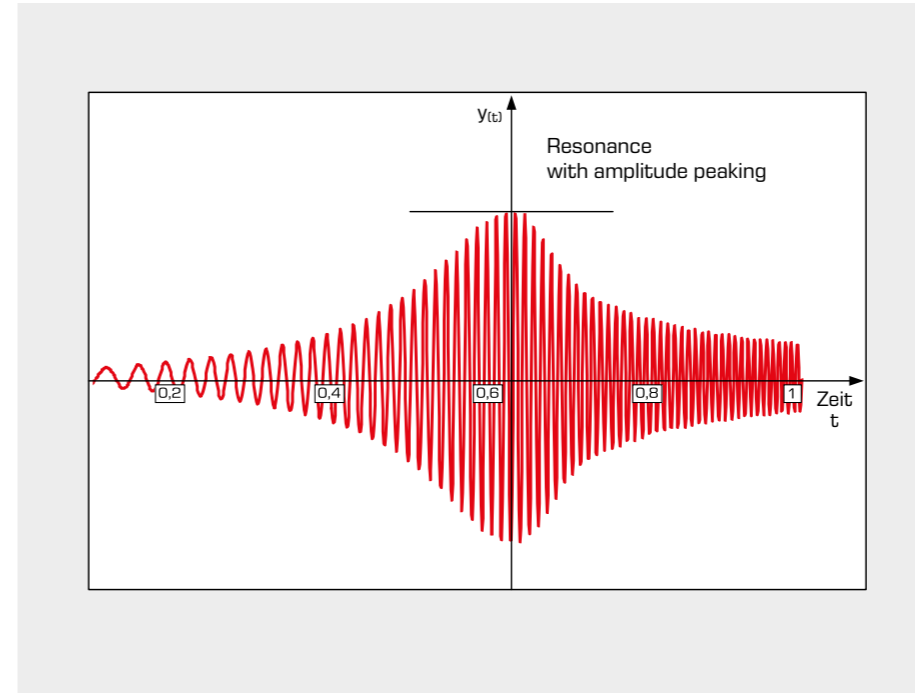
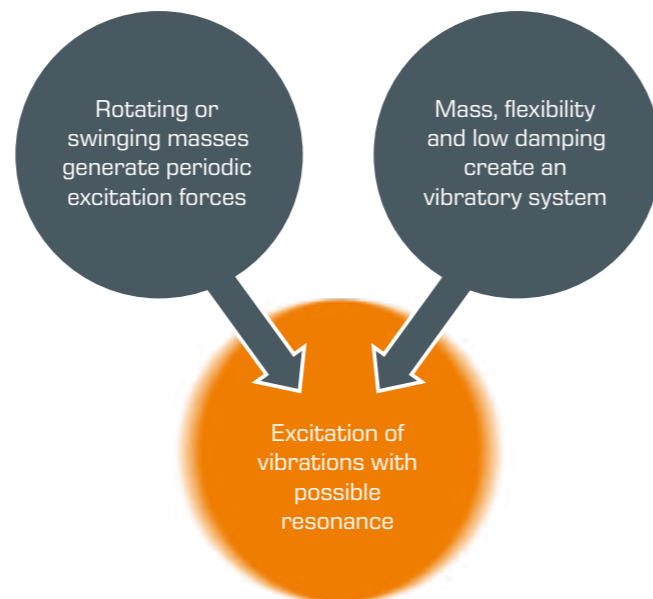

The illustration shows the increase in vibrations when passing through the resonance of a vibratory system. The very high vibration amplitudes can lead to the destruction of the machine. In practice, therefore, such resonances or critical speeds – if they cannot be avoided – must be quickly surpassed.

Measures to avoid vibration problems

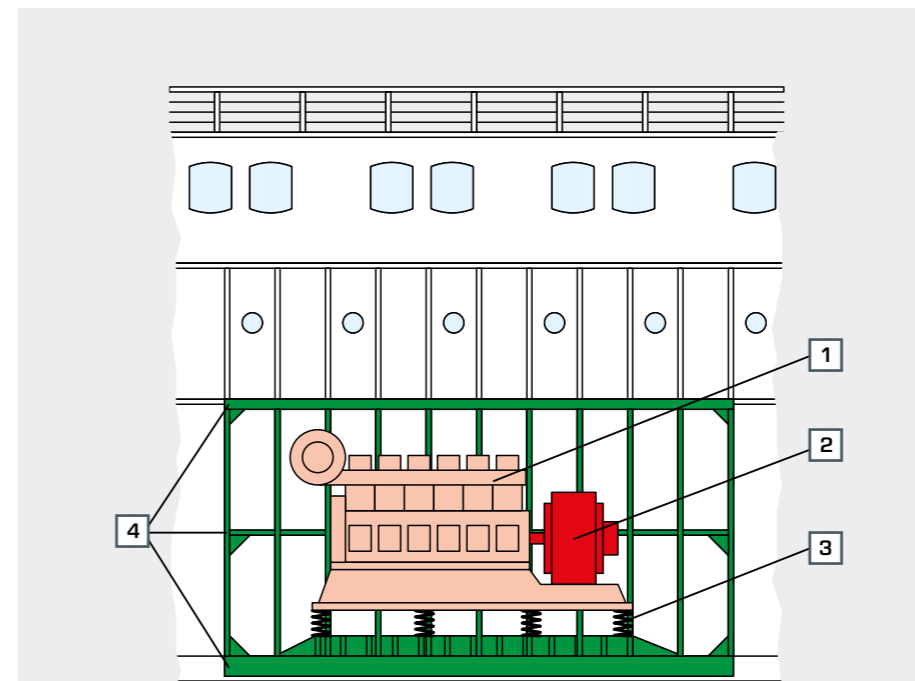

Minimising undesired vibrations using the example of a ship's engine system:

- 1 diesel engine equipped with mass balancing,
- 2 balanced generator, 3 spring-loaded support for vibration isolation,
- 4 reinforced ship structure to make the system more rigid

Vibrations should be combated at the source wherever possible. Thus, the procedure should follow the priorities presented here:

- minimise excitation forces by balancing or mass balancing
- prevent propagation of the forces by isolating the vibrations or absorbing the vibrations
- reduce vibratory capacity of the system by making the components more rigid, applying additional mass or using dampers

Basic knowledge

Machine dynamics

In machine dynamics, real machines are represented by theoretical models. More often than not, however, machines are very complicated and not easy to calculate. By simplification and abstraction, mathematical models can be obtained for both

vibratory systems and for the sources of excitation forces. Using these mathematical models, it is relatively quick and easy to predict the behaviour of the machine.

Linear vibratory system with one or more degrees of freedom

The simplest model of a vibratory system is the spring-mass system. This model provides many insights into the behaviour of a vibratory system. Often the rigidity and mass distributions of a real system can be described sufficiently well by using concentrated point masses and inertia-free springs.

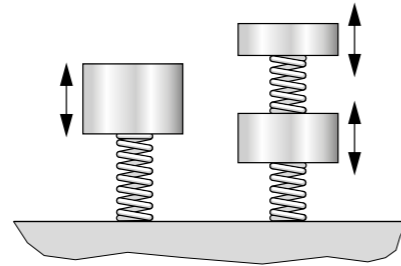

Spring-mass system

Continuous vibratory system

Similarly, simple systems exist for continuous vibration systems such as a ship's hull. In this case, a simple-beam model provides initial indications of the vibratory behaviour when excited by ocean waves. Natural frequencies and their associated natural modes are of interest here.

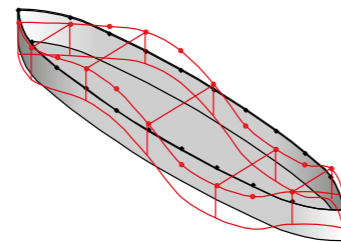

Second order natural frequency of a ship's hull

Rotor dynamics

Rotating machines can cause vibrations due to rotating masses. In elastic rotors, the rotating inertia forces can cause bending vibrations and resonances. Similarly, a non-uniform rotation can cause torsional vibrations.

Knowledge of bending-critical and torsion-critical speeds is essential for the design and subsequent operation of the machine.

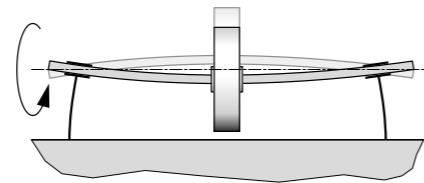

Elastic shaft with mass disk

Balancing rotors

The vibrations on rotating machines can be reduced through balancing. In this process, the excitation forces caused by the rotating masses are minimised. We attempt to match the centre of gravity and the axis of inertia of the rotor with the axis of rotation by applying or removing masses. This method is particularly useful, as balancing eliminates the cause of the vibrations.

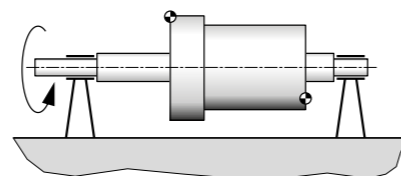

Rotor with points for mass balancing

Reciprocating engines

Machine dynamics plays an important role in reciprocating engines. Various inertia forces are produced by large back-and-forth and rotating masses. These forces can cause considerable vibration problems in a poor design. The resulting inertia forces can be kept small by distributing the masses over several cylinders, suitable kinematic ratios and the arrangement of balancing masses. This enables a low-vibration operation of the reciprocating engine.

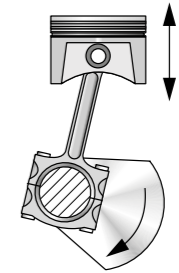

Crank mechanism

Cam mechanism

Cam mechanisms are used to convert a rotating motion into a back-and-forth motion. Cam mechanisms are used as a valve drive in engines or in packing machines. Poorly designed cam mechanisms produce high accelerations and inertia forces. This results in vibrations and noise. The application of machine dynamics allows a design with the lowest possible loads and vibrations.

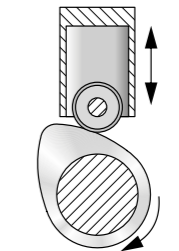

Camshaft with roller plunger

Machine foundations and supports to isolate vibrations

Machine foundations or supports are designed so that the transmission of vibrations from the machine to the environment is largely prevented. This prevents unpleasant vibrations of buildings, plants or motor vehicles. This is known as vibration isolation. Using the methods of machine dynamics, the properties of the machine supports are determined and the effects on the environment are calculated.

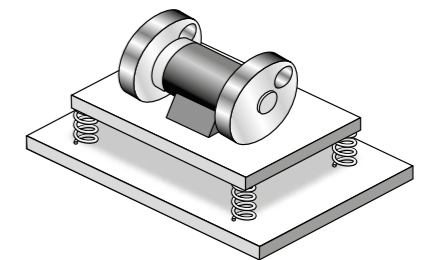

Imbalance generator on spring-loaded foundation

Contents of machine dynamics

Linear vibratory systems with one degree of freedom	TM 150, TM 150.02, TM 155
Linear vibratory systems with several degrees of freedom	TM 150, TM 140, TM 182
Vibrations in continuous systems	HM 159.11, TM 625
Rotor dynamics, bending-critical speeds	TM 620, TM 625, PT 500.10
Balancing technology	TM 170, PT 500, PT 500.10, PT 502
Machine dynamics in reciprocating engines	TM 180, PT 500.16
Vibrations on crank drives	GL 112
Vibration isolation	TM 182, TM 182.01
Vibration measuring equipment and fundamentals of frequency analysis	PT 500 ff, HM 159.11, TM 182
Machinery status monitoring	PT 500 ff, PT 501

GUNT offers an extensive range of experimental units in the field of machine dynamics. The programme is based on a typical curriculum for machine dynamics. Furthermore, units are available for vibration measuring methods and machine diagnosis.

TM 155

Free and forced vibrations



Description

- demonstration of basic fundamentals of mechanical vibration theory
- damping and resonance in forced vibrations
- two different principles of vibrational excitation

Forced vibrations occur in a variety of ways in engineering. While they are desirable in vibrating screens or vibrating conveyors, they are often unwanted in engines or other rotating machines. The TM 155 experimental unit clearly demonstrates the fundamentals needed to deal with free and forced vibrations. The differences between the two main types of excitation for forced vibrations can be shown on a simple vibration model.

The central element of the experimental unit is a sturdy aluminium profile frame to which the different experimental setups are attached. A bar-type oscillator is used as the vibration system. This offers easy and flexible configuration.

The spring, damper and vibration exciter can be mounted in any position. An imbalance exciter and a displacement exciter are available for spring base-point excitation.

The excitation frequency is set and displayed on a control unit. An oil hydraulic damper allows damped vibrations with adjustable damping level. A mechanical drum recorder offers the option of recording the vibrations. The measured values can be displayed and analysed on a PC using the optional TM 155.20 unit for data acquisition. A demonstration unit for torsional vibrations (TM 150.02) is available as an accessory.

Learning objectives/experiments

- free vibrations
- damped vibrations
- inertia force and displacement excitation
- forced vibrations
- resonance
- amplitude response and phase response

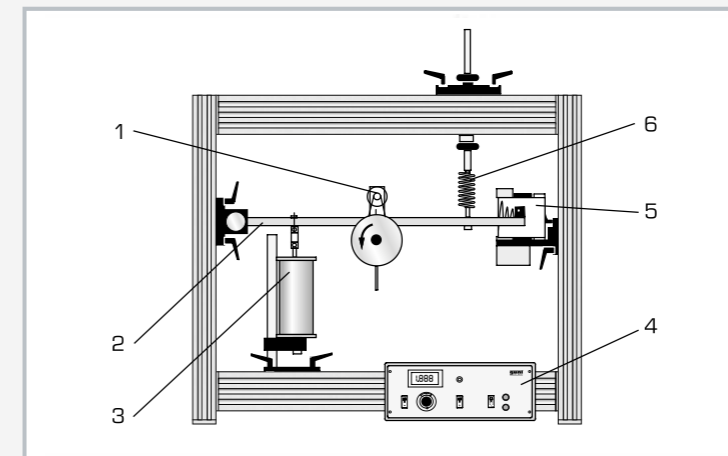

1 imbalance exciter, 2 rigid bar as discrete oscillator, 3 damper, 4 control unit for imbalance exciter, 5 drum recorder for recording vibrations, 6 suspension and vibration spring

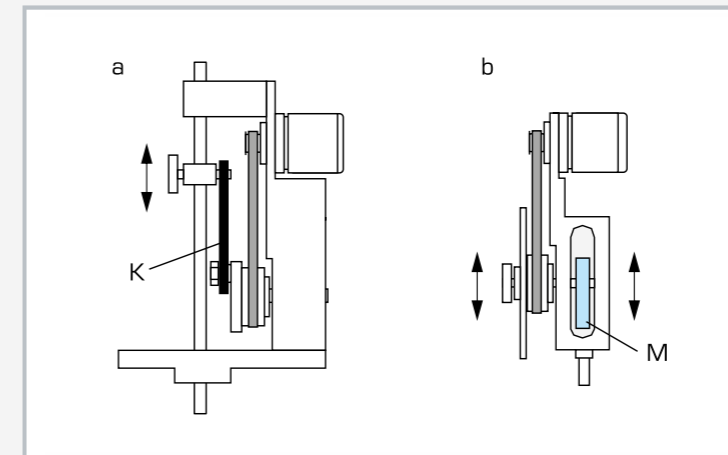

a) displacement exciter with rigid coupling rod K, b) imbalance exciter with eccentrically mounted flywheel disk M

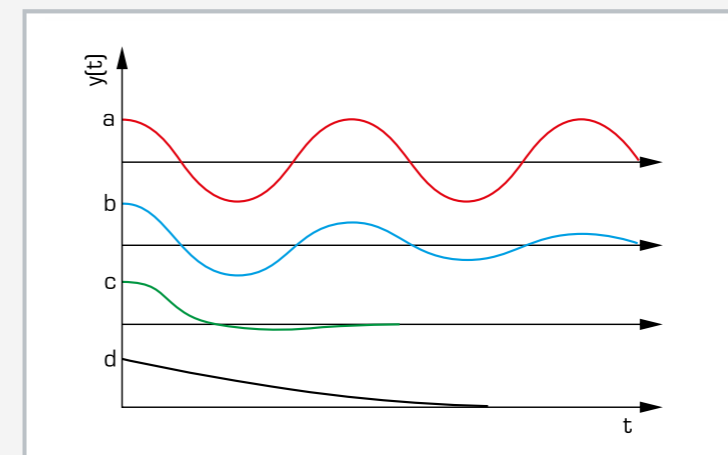

Modes of vibration for varying damping D: a) no damping, $D = 0$, continuous vibration, b) low damping, $0 < D < 1$, c) $D = 1$, aperiodic limit case, d) strong damping, $D > 1$, creep case; y elongation, t time

Specification

- [1] fundamentals of mechanical vibration theory; free, damped and forced vibrations
- [2] bar-type oscillator
- [3] 3 coil springs
- [4] imbalance exciter with DC motor
- [5] displacement exciter with DC motor
- [6] electronic control unit with digital display, adjustable excitation frequency
- [7] damper with oil fill
- [8] electrically driven drum recorder
- [9] amplitude meter with electrical contact for triggering devices
- [10] storage system for parts

Technical data

Bar-type oscillator: LxWxH: 700x25x12mm, 1,6kg
Coil springs
 ■ 0,75N/mm
 ■ 1,5N/mm
 ■ 3,0N/mm

Exciter frequency: 0...50Hz, electronically controlled
Imbalance of the imbalance exciter: 0...1000mmg
Stroke of the displacement exciter: 20mm
Damper constant: 5...15Ns/m, oil-filled

Mechanical drum recorder
 ■ feed: 20mm/s
 ■ paper width: 100mm

230V, 50Hz, 1 phase
230V, 60Hz, 1 phase; 120V, 60Hz, 1 phase
UL/CSA optional
LxWxH: 1000x420x900mm
Frame opening WxH: 870x650mm
Weight: approx. 52kg
Storage system:
LxWxH: 1170x480x237mm
Weight: approx. 12kg

Scope of delivery

- 1 experimental unit
- 1 bar-type oscillator
- 3 coil springs
- 1 imbalance exciter
- 1 displacement exciter
- 1 control unit for imbalance exciter
- 1 damper
- 1 amplitude meter
- 1 drum recorder
- 1 storage system with foam inlay
- 1 set of instructional material

TM 150.02

Free and damped torsional vibrations



Description

■ influence of mass, torsional rigidity and damping on the behaviour of a rotary oscillator

Torsional vibrations play a major role in drive systems. Selecting an inappropriate natural frequency can lead to resonance phenomena, which in some circumstances may lead to serious damage.

The TM 150.02 unit can be used to produce free torsional vibrations and to study the effects of torsional stiffness, mass and damping on frequency and amplitude. The accessory kit is designed to be installed in the TM 150 or TM 155 vibration trainers.

The accessory kit contains three different torsion bars and two different mass disks with which to create torsional vibrations.

The rigidity of the torsion bars can be adjusted by selecting the effective length of the bar, such that the natural frequency of the torsional vibration can be adjusted within wide limits.

Bearings and mass disks are clamped to positions on the torsion bars using clamping chucks. An oil damper is used to display damped vibrations. The vibrations are recorded on the TM 150/TM 155 recorder.

Learning objectives/experiments

- natural frequency of a rotary oscillator
- influence of torsional stiffness, mass and damping

Specification

- [1] supplementary experiment for torsional vibrations for the TM 150 and TM 155 vibration trainers
- [2] 3 torsion bars with different diameters, freely selectable effective length
- [3] 3 different mass disks with clamping chuck
- [4] 3 with ball bearings and clamping chuck
- [5] oil damper for damped vibrations
- [6] recorder for recording the vibrations in TM 150/TM 155

Technical data

Torsion bars, stainless steel

- Ø 3mm, 5mm, 6mm
- length: 800mm

Mass disks

- small: Ø 150mm approx. 2,7kg
- large: Ø 228mm approx. 4,8kg

Clamping chuck: Ø 0,5...8,0mm

LxWxH: 480x240x1180mm
Weight: approx. 33kg

Scope of delivery

- 1 experimental unit
- 1 set of instructional material

TM 155.20

System for data acquisition

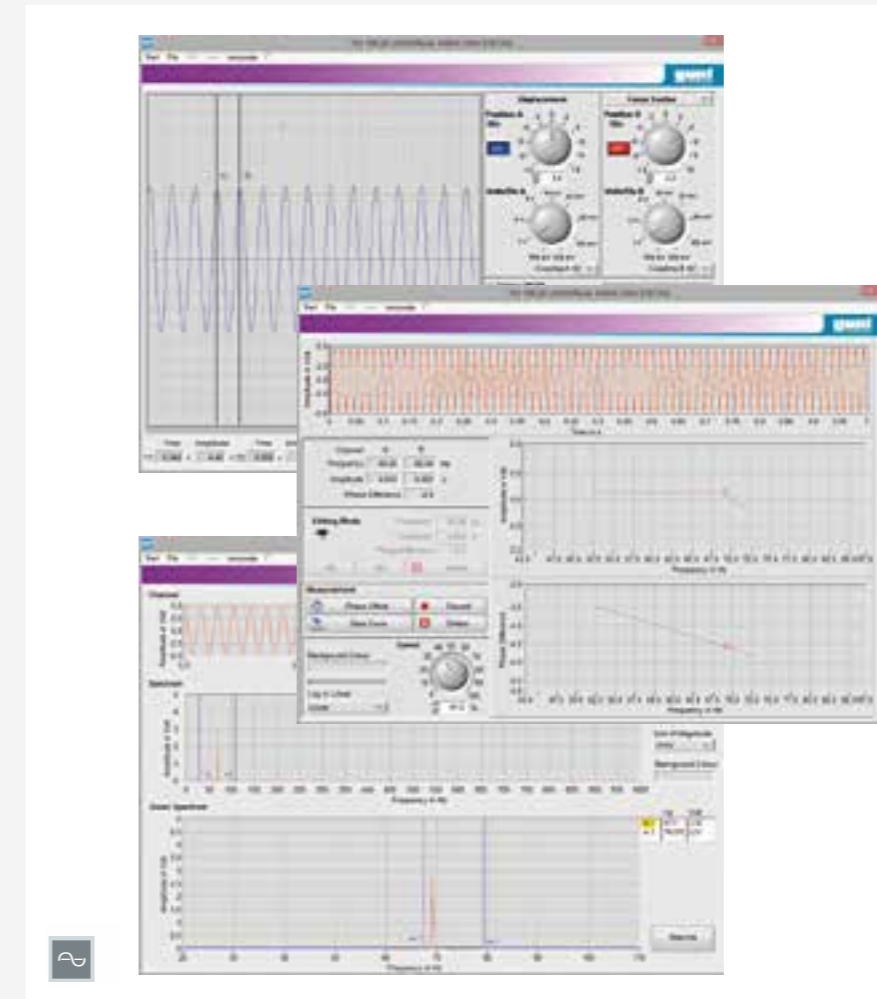

Description

■ measurement and illustration of frequency and phase response

■ digital storage oscilloscope

This system for data acquisition is an addition to the experimental unit TM 155 and makes it possible to analyse vibration signals on a PC. Frequency and phase response curves can be easily generated, saved and output using this system. The system also offers all the essential functions of a digital storage oscilloscope and can calculate the frequency spectra of the signals.

In addition to the software, a displacement sensor and a reference sensor, the system also includes an interface box. The box supplies up to three sensors, prepares their measuring signals for the PC and offers them to three analogue outputs for display.

All components of the system are ready at hand and securely housed in a storage system.

Learning objectives/experiments

- supported experiments with TM 155
 - ▶ natural vibration of a bar-type oscillator
 - ▶ damped vibration of a bar-type oscillator
 - ▶ forced vibration of a bar-type oscillator (damped and undamped resonance)
 - ▶ frequency and period time measurements

Specification

- [1] data analysis for TM 155
- [2] measurement, recording and analysis of frequency response and transfer function
- [3] function as digital storage oscilloscope
- [4] interface box with 3 sensor inputs, 3 analogue outputs
- [5] 1 inductive displacement sensor (amplitude), 2 reference sensors (exciter force)
- [6] GUNT software for data acquisition via USB under Windows 7, 8.1, 10

Technical data

Sensor input channels: 3
Inputs in oscilloscope mode: 2
Time basis: 10 ... 750ms/DIV
Record length: 2000 points

Displacement sensors

- measuring range: 5...10mm
- frequency range: 0...50Hz

230V, 50Hz, 1 phase
230V, 60Hz, 1 phase
120V, 60Hz, 1 phase; UL/CSA optional
LxWxH: 265x260x110mm (interface box)
Weight: approx. 7kg
LxWxH: 600x400x170mm (storage system)

Required for operation

PC with Windows

Scope of delivery

- 1 interface box
- 1 displacement sensor
- 2 reference sensors (exciter force)
- 1 GUNT software CD + USB cable
- 1 set of cables
- 1 storage system
- 1 manual

TM 140

Free and forced torsional vibrations



Description

- investigation of torsional stiffness and torsional vibrations
- behaviour of two-mass and three-mass torsional oscillators

Torsional vibrations are often observed in belt-driven systems. With appropriate excitation of resonances, large vibration amplitudes can occur, which can lead to strong loads on shafts and gears, potentially resulting in damage.

The TM 140 unit can be used to produce free and forced torsional vibrations and to study the effects of torsional stiffness, mass and damping on frequency and amplitude.

The core of the experimental unit is a metal torsion bar. Mass disks with different rotational inertias can be attached to the bar using clamping chucks. This allows a torsional vibration system to be created with up to three masses. The torsional stiffness can be adjusted by varying the effective bar length. An exciter unit driven by an electric motor is used to represent forced vibrations. The frequency can be adjusted and read on the control unit.

A damper makes it possible to set different degrees of damping. The torsional vibrations are picked up via rotary encoders on the bearings of the torsion bar and are available on the control unit as an electrical signal. All signals are also available via a USB port and can be transferred to a PC.

The GUNT software allows the signals to be recorded and analysed, for example recording a resonance curve or displaying the natural mode.

Learning objectives/experiments

- determine the torsional stiffness of a torsion bar
- determine the mass moments of inertia
- decay behaviour of torsional vibrations
- determine the damping in torsional vibrations
- forced torsional vibrations, resonance
- torsional vibration systems with multiple masses
 - ▶ two-mass torsional oscillator
 - ▶ three-mass torsional oscillator

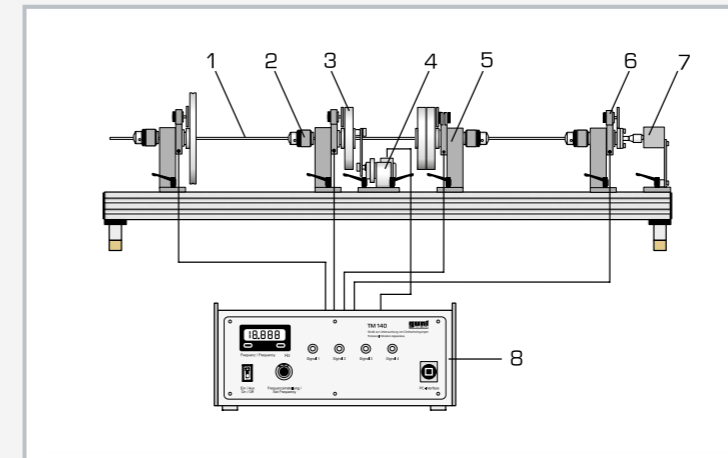

1 torsion bar, 2 clamping chuck, 3 mass disk, 4 exciter unit, 5 bearing unit, 6 rotary angle sensor, 7 damper unit, 8 display and control unit

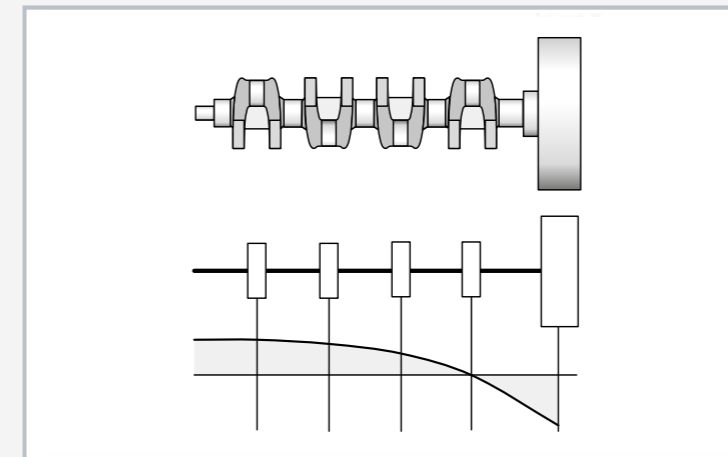

Crankshaft as an example of a torsional oscillator

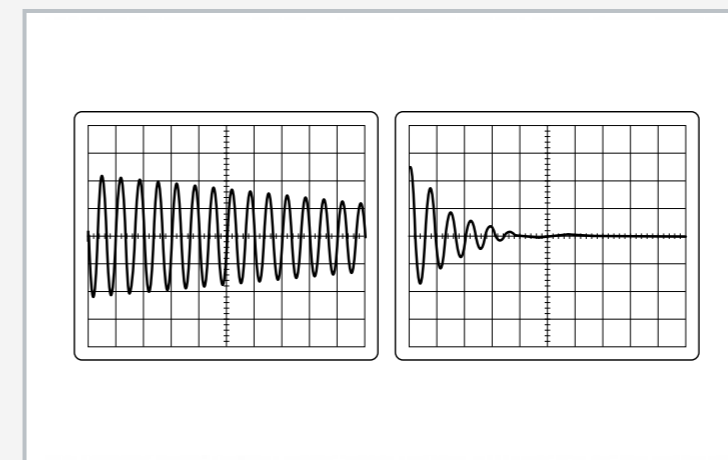

Example oscillograph: left – torsional vibration of a torsion bar with mass disk, weakly damped; right – the same vibration with strong damping

Specification

- [1] experimental unit for investigating torsional vibrations and torsional stiffness
- [2] 3 mass disks
- [3] 4 freely positionable ball-bearing-mounted units with clamping chucks
- [4] sealed oil damper
- [5] exciter unit with drive crank; exciter amplitudes 1,4°, 1,8°, 2,4°
- [6] 4 rotary angle sensors, 0,03V/°
- [7] electrical exciter control unit for setting and displaying the exciter frequency and for powering the rotary encoder
- [8] GUNT software for data acquisition via USB under Windows 7, 8.1, 10

Technical data

Torsion bar

- 1300mm
- $\varnothing=6\text{mm}$
- stainless steel

Rigidity: approx. 1,0Nm/rad/m

Mass disks

- $\varnothing=150\text{mm}$, approx. 2,7kg
- $\varnothing=228\text{mm}$, approx. 4,8kg

Exciter frequency: 1...20Hz

Damper coefficient: 0,25...3,5Nm/rad/s

230V, 50Hz, 1 phase

230V, 60Hz, 1 phase; 120V, 60Hz, 1 phase

UL/CSA optional

LxWxH: 1400x410x400mm

Weight: approx. 50kg

Required for operation

PC with Windows recommended

Scope of delivery

- 1 experimental unit
- 4 bearing units
- 1 torsion bar
- 3 mass disks
- 1 exciter
- 1 rotational damper
- 1 control unit
- 1 set of cables
- 1 hexagon screwdriver size 4
- 1 GUNT software CD + USB cable
- 1 set of instructional material

HM 159.11

Natural vibration on a ship model



Description

- dynamic behaviour of a ship structure
- simple ship form simplifies the mathematical approach
- different excitation signals possible
- optional excitation and measuring points

Nowadays, experiment-based vibration analysis is an essential component in shipbuilding design and development.

The HM 159.11 unit helps students take their first steps in the field of experimental vibration analysis or modal analysis of structures. Using this trainer, the dynamic behaviour of a ship structure is studied, teaching students the fundamentals of experimental vibration analysis.

The HM 159.11 unit can be used to measure and record the natural frequencies and modes of a model ship. The simple, idealised ship shape makes it easier to approach the problem mathematically. The plastic model ship has nine ribs and an elliptical line plan.

The model ship is attached to a rigid cross-member by springs. The enclosed box cross-section with high rigidity means the natural frequency of the cross-member is negligibly high.

An electrodynamic vibration exciter causes the model ship to vibrate. A function generator produces the excitation signal, which can be adjusted in amplitude and frequency. An arbitrarily positionable acceleration sensor measures the model's response to the excitation signal. In this manner, the transfer functions for various points of the model ship can be generated step by step. These can be used to determine the vibration modes for various natural frequencies. Experiments can also be conducted in water.

An additional tank is required to conduct these experiments (not included). Complementary experiments can be conducted with additional ballast and weights.

Learning objectives/experiments

- measure and record natural frequencies and modes of the model ship (in air)
- vibration behaviour of the model ship in air
- comparison between theory (approximation formula for determining the first bending frequency) and practice (measured natural frequency)
- influence of discrete additional masses or ballast on natural frequency and mode (ballast and extra weights not included)
- vibration behaviour of floating model ship (possible with additional tank)

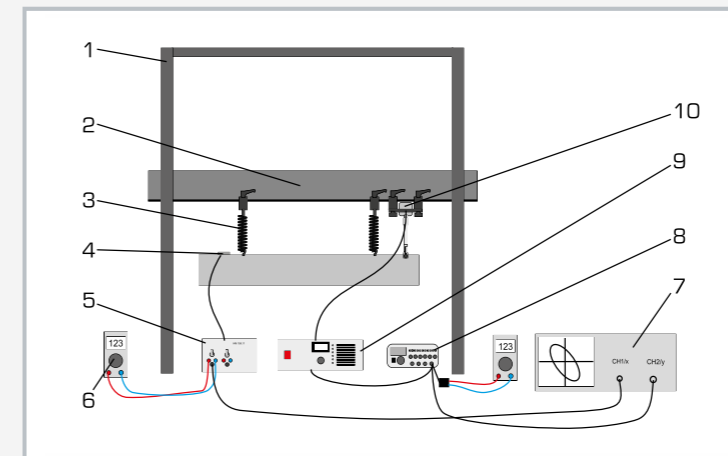

1 frame, 2 adjustable height cross-member, 3 springs for suspending the model ship, 4 acceleration sensor, 5 measuring amplifier, 6 multimeter, 7 oscilloscope (not included), 8 function generator, 9 power amplifier for vibration exciter, 10 vibration exciter

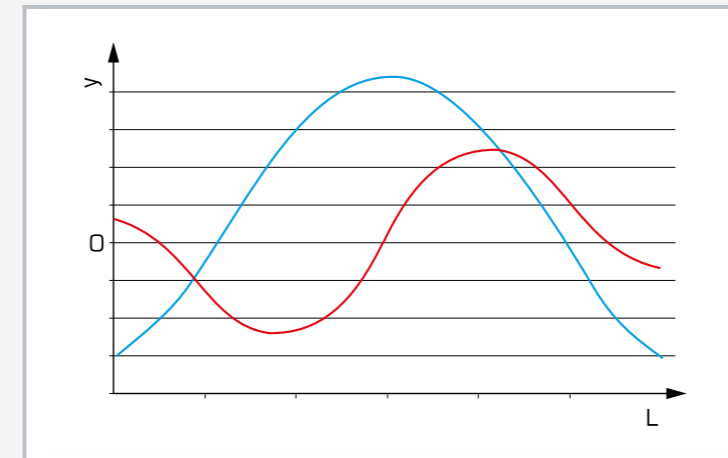

Elongation y of the vibration, shown over the length L of the model ship
blue: first order natural frequency, red: second order natural frequency

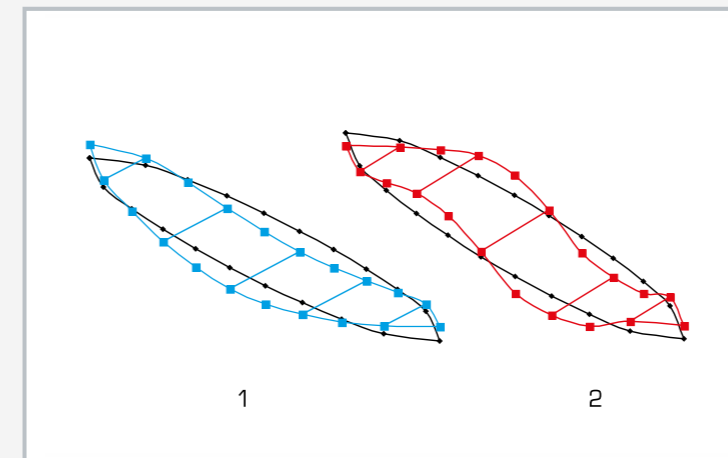

1 blue: first order natural frequency, 2 red: second order natural frequency

Specification

- [1] vibration behaviour of a model ship in air and in water (with additional tank)
- [2] model ship mounted on springs; vibration excitation and acceleration measurement at any point
- [3] frame with height-adjustable cross-member for attaching the model
- [4] high natural frequency of the cross-member owing to enclosed box cross-section with high rigidity and low weight
- [5] plastic model ship with elliptical lines plan and 9 ribs
- [6] capacitive acceleration sensor with measuring amplifier, freely positionable
- [7] vibration exciter with power amplifier and function generator: sinusoidal, triangular or rectangular signal
- [8] possible to display measured values on an oscilloscope (not included)

Technical data

Vibration exciter

- electrodynamic type with permanent magnet
- max. force: 8,9N
- frequency range: 5...12000Hz

Function generator

- adjustable frequency, amplitude and offset
- output: 0...10Vss, 50 Ohm

Acceleration sensor

- measuring range: $\pm 5g$
- frequency range: 0...400Hz

Model ship

- deck stringer with fastening holes for sensors and suspension

230V, 50Hz, 1 phase
230V, 60Hz, 1 phase; 120V, 60Hz, 1 phase
UL/CSA optional
LxWxH: 1800x400x1700mm (frame)
LxWxH: 1200x200x150mm (model ship)
Weight: approx. 50kg

Scope of delivery

- 1 trainer
- 1 model ship
- 4 springs
- 1 measuring amplifier
- 1 power amplifier
- 1 vibration exciter
- 1 function generator
- 2 multimeters
- 1 acceleration sensors
- 1 set of cables
- 1 set of instructional material

TM 620

Bending elasticity in rotors



Description

- investigation of bending vibrations in rotors
- determine critical speeds
- positions of rotor bearing and rotating mass can be adjusted

Critical speed and resonance are phenomena that play essential roles in many machines and systems. In particular, resonance states with impermissibly high vibration amplitudes can occur in rotating shafts and rotors at certain speeds, which in some cases can even lead to destruction of the machine. To prevent this, the system is operated well above or below the critical speed and driven quickly through the critical speed range. Therefore, knowledge of critical speeds and vibration modes is important in the design and operation of machines with bending elasticity in their rotors.

The TM 620 experimental unit can be used to clearly demonstrate phenomena such as resonance, self-centring and vibration modes. The model-like structure of the experimental rotor as a thin, elastic shaft with rigid mass disks allows simple theoretical comprehension of the vibration phenomena that occur.

The influence of different parameters can be studied thanks to the free choice of bearing and disk arrangement. The limitation of the amplitudes at a rapid resonant cycle can also be demonstrated.

A three-phase motor drives a rotor shaft, onto which one or two masses may be fixed at various distances. The rotor shaft is mounted in two self-aligning ball bearings and connected to the motor via a flexible coupling. The electronically controlled speed can be selected via two potentiometers and is continuously variable. It is displayed on a digital display.

The positions of and distances to elements fixed onto the rotor shaft can be read on a scale mounted in parallel with the rotor.

A transparent protective cover and safety bearings immediately next to the masses ensure safe operation.

The measured values can be displayed and analysed on a PC using the optional TM 620.20 unit for data acquisition.

Learning objectives/experiments

- investigate bending vibrations and resonance of a rotating shaft
- determine critical speeds with different arrangements of the bearing and masses on the rotor shaft and compare with theory
- investigation of the rotor's self-centring effect

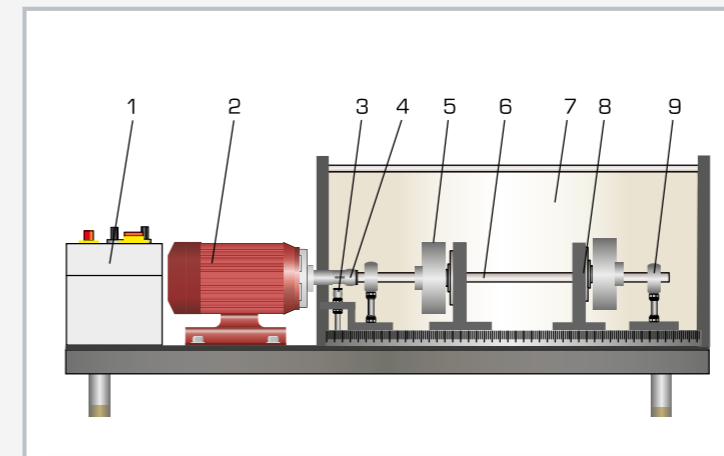

1 switch box, 2 motor, 3 inductive speed sensor, 4 flexible coupling, 5 mass disk, 6 rotor shaft, 7 protective cover, 8 safety bearing, 9 self-aligning ball bearing

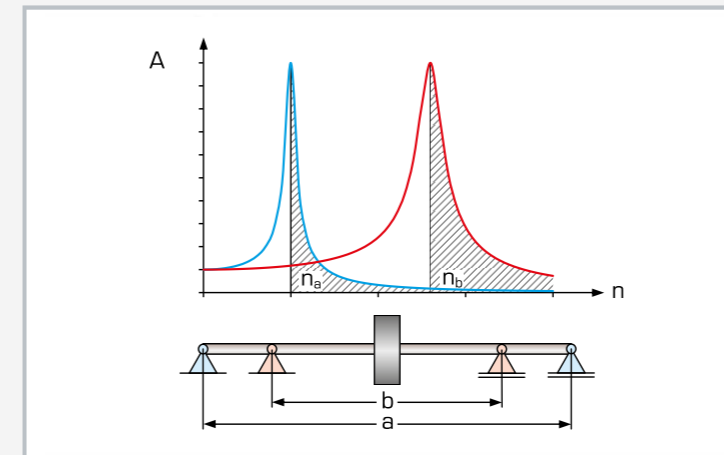

Reducing the bearing clearance increases the critical speed; A amplitude, n speed; n_a critical speed at bearing clearance a, n_b critical speed at bearing clearance b, shaded area: supercritical speed

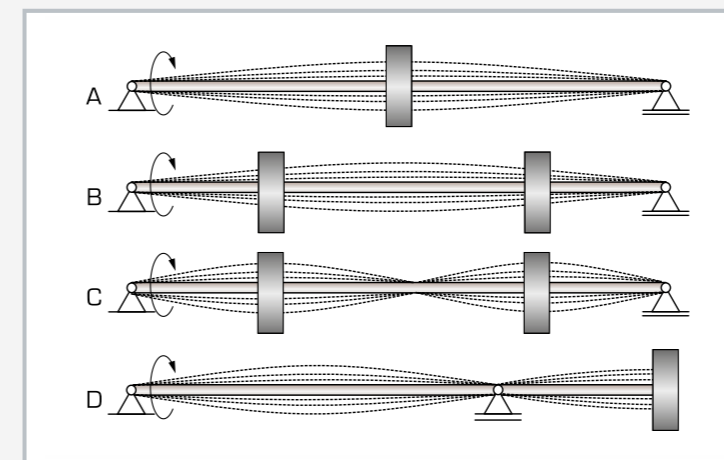

Various arrangements for studying the critical speed: A one mass disk central position, B two mass disks at first critical speed, C two mass disks at second critical speed, D overhung mass disk

Specification

- [1] investigation of bending vibrations and resonance in rotors
- [2] 2 self-aligning ball bearings to support the rotor shaft, positionable at any point
- [3] 2 masses to be secured at any point
- [4] safety bearing and transparent protective cover for safe operation
- [5] three-phase motor: 2 pre-selectable speed ranges; speed electronically controlled and continuously adjustable
- [6] digital speed display
- [7] system for data acquisition (TM 620.20) available as an option

Technical data

Three-phase motor

- power: 0,25kW
- max. speed: 3000min⁻¹

Rotor shaft

- L=500mm
- Ø 6mm
- high tensile steel

Mass 2x, disk-shaped

- m=965g
- Ø 80mm
- hardened steel

Rotor bearing

- 2x self-aligning ball bearings
- 2x safety bearings
- safety bearing play: ±3mm
- adjustable bearing clearance: 300...470mm

Measuring ranges

- speed: 300...3000min⁻¹
- scale for measuring distance: 0...500mm

230V, 50Hz, 1 phase

230V, 60Hz, 1 phase; 120V, 60Hz, 1 phase

UL/CSA optional

LxWxH: 1150x390x375mm

Weight: approx. 49kg

Scope of delivery

- 1 experimental unit
- 1 set of instructional material

TM 625

Elastic shafts



Description

- investigation of the natural modes of various shafts with continuous mass distribution and of a Laval rotor
- optimal visibility and simultaneous protection thanks to transparent protective cover

The terms "critical speed" and "resonance" are often used when referring to rotating systems. Resonance occurs when the natural frequency and the excitation frequency match. The natural frequency of an oscillatory system is that frequency at which the system oscillates with the associated natural mode after a single excitation. Operation at critical speed can damage the system because of the high vibration amplitudes. In order to study the phenomenon of shaft vibration in more detail, there are two simplified calculation models. In the first case, the mass of the elastic shaft is evenly distributed along its length. In the second case, the shaft consists of massless, elastic shaft sections and the masses are combined into discrete mass disks.

The TM 625 experimental unit can be used to study the natural modes of these different models. Illustrative experiments are used to explain resonance and the supercritical or subcritical states of a vibrating system. Six shafts of different lengths and diameters are available. The shafts can be mounted on four self-aligning ball bearings and fitted with a mass disk to construct a Laval rotor. The axial positions are read on a scale mounted parallel to the shaft. A three-phase motor drives the shaft via a flexible coupling. The electronically controlled speed can be selected via two potentiometers and is continuously variable. It is displayed digitally.

A transparent protective cover and safety bearing ensure safe operation.

The measured values can be displayed and analysed on a PC using the optional TM 620.20 unit for data acquisition.

Learning objectives/experiments

- investigation of a Laval rotor
 - ▶ critical speed
 - ▶ self-alignment
- natural modes on a shaft with continuous mass distribution with
 - ▶ different bearing clearances
 - ▶ different shaft diameters
 - ▶ different shaft lengths

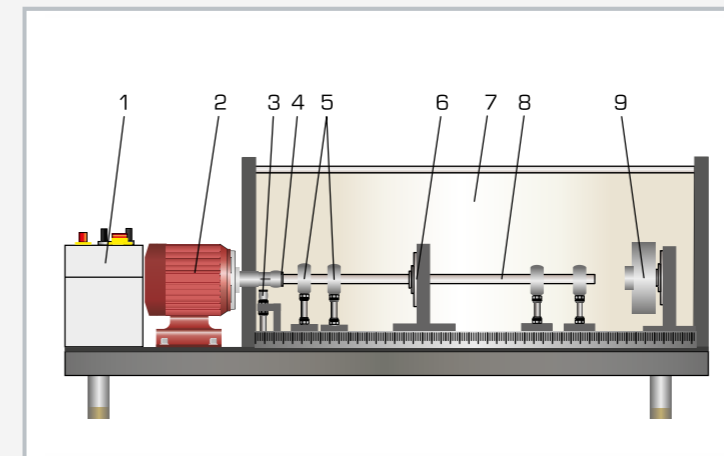

1 switch box, 2 motor, 3 inductive speed sensor, 4 elastic coupling, 5 self-aligning ball bearings, 6 safety bearing, 7 protective cover, 8 shaft, 9 mass disk

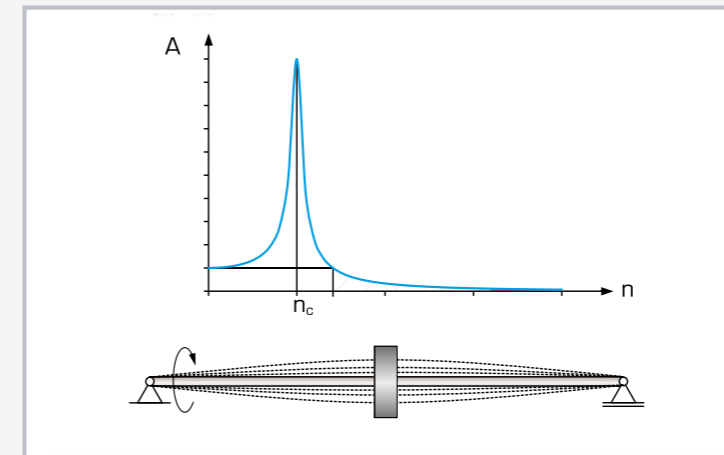

Vibration behaviour of a Laval rotor: n speed, A amplitude, n_c critical speed with resonance, shaded area: subcritical speed, red shaded area: supercritical speed with self-centring

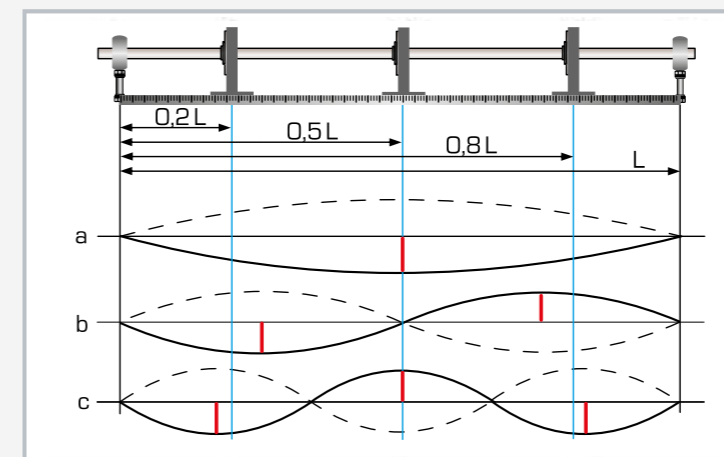

Natural modes of a shaft with continuous mass distribution: a) first natural mode, b) second natural mode, c) third natural mode; red: amplitude of the vibration, blue: position of the safety bearing; L clearance of the shaft bearing

Specification

- [1] experimental unit for determining critical speeds and investigating the natural modes of a shaft
- [2] 6 high-tensile steel shafts
- [3] up to 4 self-aligning ball bearings, each moveable to any point as a shaft bearing
- [4] 1 mass for constructing a Laval rotor
- [5] 3 safety bearings and transparent protective cover for safe operation
- [6] three-phase motor: 2 pre-selectable speed ranges; speed electronically controlled and continuously adjustable
- [7] digital speed display
- [8] system TM 620.20 for data acquisition available as an option

Technical data

6 shafts
 ■ Ø 3mm, 6mm, 7mm
 ■ L: 600mm, 900mm
 ■ high-tensile steel

Mass, disk-shaped
 ■ Ø 80mm
 ■ m: 965g
 ■ high-tensile steel

Motor
 ■ power: 0,25kW
 ■ max. speed: 6000min⁻¹
 ■ speed electronically controlled

Shaft bearing
 ■ 4x self-aligning ball bearings
 ■ 3x safety bearings

Measuring ranges
 ■ speed: 0...6000min⁻¹
 ■ scale for clearance measurement: 0...1000mm

230V, 50Hz, 1 phase
 230V, 60Hz, 1 phase; 120V, 60Hz, 1 phase
 UL/CSA optional
 LxWxH: 1550x380x450mm
 Weight: approx. 65kg

Scope of delivery

- 1 experimental unit
- 6 shafts
- 1 set of tools
- 1 set of instructional material

TM 620.20

System for data acquisition

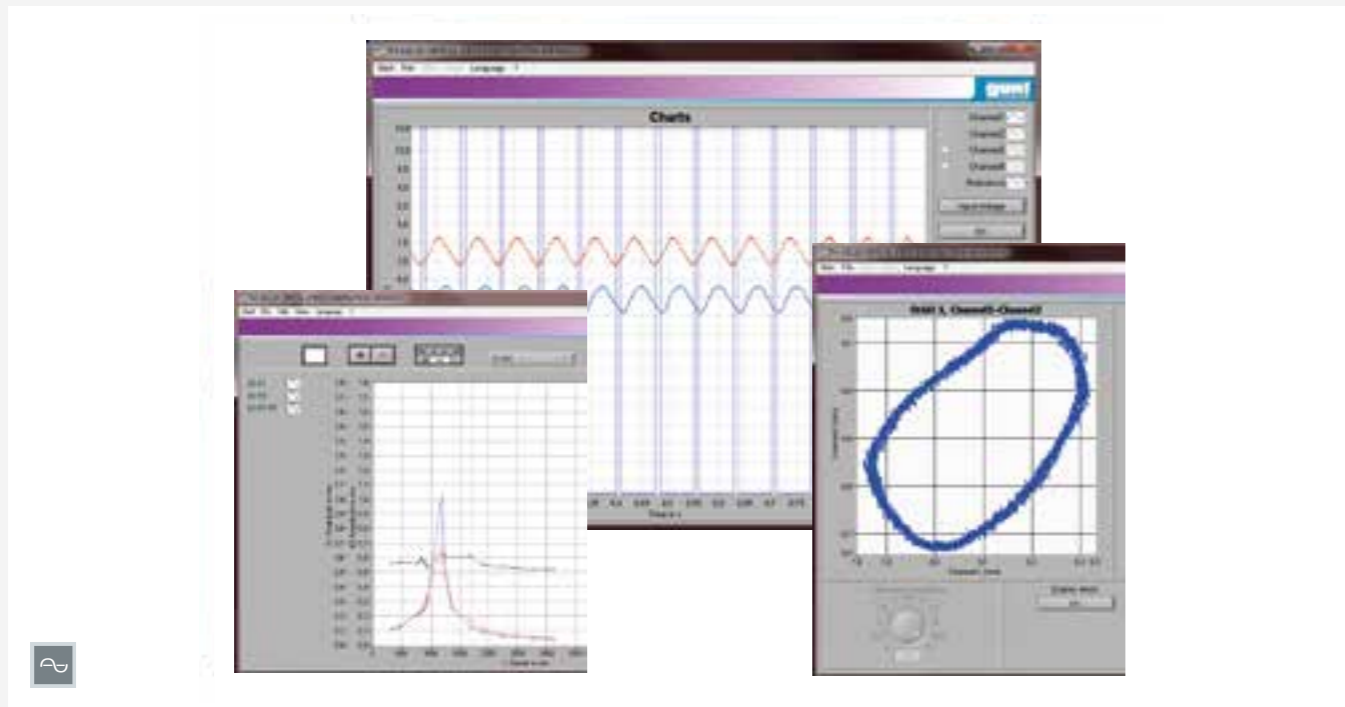

Description

- measurement and representation of shaft vibrations as a function of speed
- representation of a digital oscilloscope
- suitable for all experiments with the TM 620 and TM 625 experimental units

The TM 620.20 system for data acquisition, as an accessory for the TM 620 and TM 625 experimental units, enables vibrations to be recorded and analysed. The system consists of two inductive displacement sensors, a measuring amplifier and software for further processing and displaying the measured values.

The two displacement sensors take contactless measurements of the deflection of the rotating mass disks on the elastic shaft of TM 620 or TM 625. The relative position of the two displacement sensors can be varied. By arranging the displacement sensors at right angles to each other (90° offset) in the measuring plane, the movement of the shaft can be represented over one whole revolution as an orbit.

With an arrangement with two different mass disks, it is possible to measure the natural mode of the vibrating shaft. The analogue signal of the displacement sensors is digitised in the measuring amplifier and sent to a PC via USB. The GUNT software provided allows the signals to be displayed optionally as either a time series on the oscilloscope or amplitude as a function of speed.

The displacement sensors are powered by the measuring amplifier. All necessary cable connectors are included. The experiments are described in the instruction material of the TM 620 or TM 625 unit.

Learning objectives/experiments

- in conjunction with the TM 620 or TM 625 experimental units
 - ▶ investigation and representation of the vibration amplitude of a rotating shaft
 - ▶ recording of signals over time
 - ▶ investigation of how amplitude depends on speed and location
 - ▶ representation of the orbit

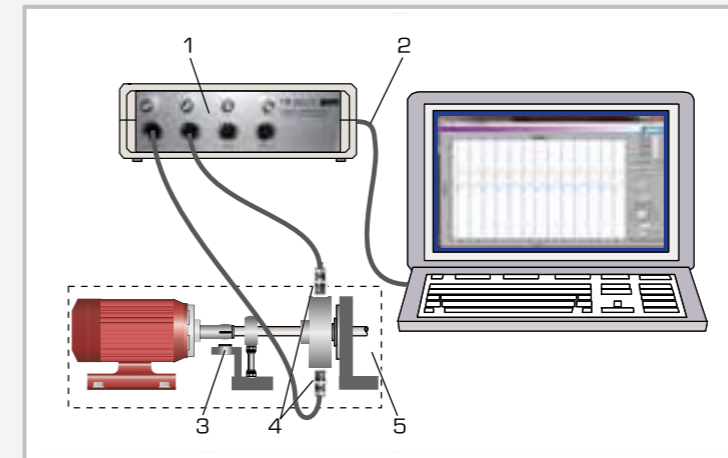

1 measuring amplifier and A-D converter, 2 USB output to PC, 3 speed sensor, 4 inductive displacement sensor, 5 TM 620 experimental unit

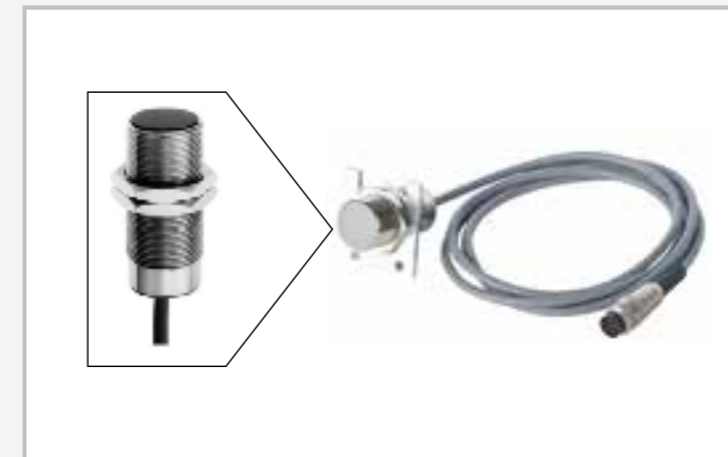

Sensors: inductive displacement sensor

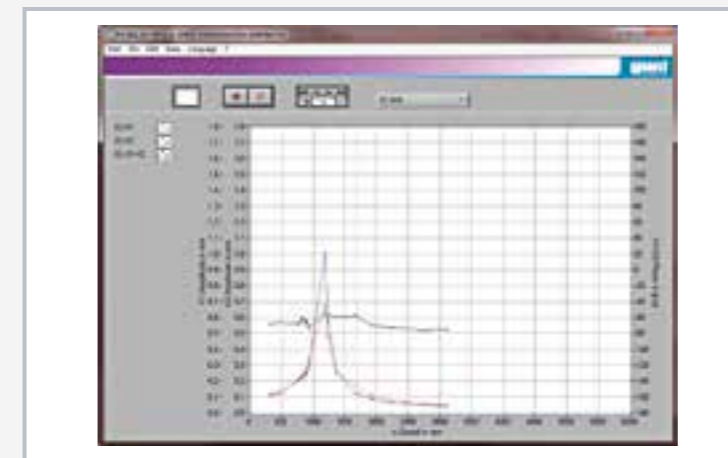

Software screenshot: representation of the amplitude as a function of the speed

Specification

- [1] data acquisition and analysis of shaft vibrations for TM 620 and TM 625
- [2] 2 inductive, non-contact displacement sensors
- [3] measuring amplifier and A-D converter for signal processing
- [4] GUNT software for data acquisition via USB under Windows 7, 8.1, 10

Technical data

- 2 displacement sensors
- measuring principle: inductive, non-contact
 - output signal: analogue 1...9V
 - measuring distance: 5...10mm
 - measuring velocity: <1,5mm/ms

Measuring amplifier

- 4 input signals
- 4 analogue output channels via BNC
- A-D converter
- output signal via USB

230V, 50Hz, 1 phase
230V, 60Hz, 1 phase; 120V, 60Hz, 1 phase
UL/CSA optional
LxWxH: 230x200x80mm
Weight: approx. 2kg

Required for operation

PC with Windows

Scope of delivery

- 1 GUNT software CD + USB cable
- 2 displacement sensors
- 1 measuring amplifier
- 1 set of cables
- 1 manual

TM 170

Balancing apparatus



Description

■ representation of the fundamental processes involved in balancing

■ static and dynamic imbalance

Imbalances on rotating machines are often the cause of disruptive vibrations and noise. During imbalance, the principal axis of inertia or centre of gravity of the rotating machine component is outside its axis of rotation. By adding or removing masses, the centre of gravity or the principal axis of inertia can be shifted so that both coincide with the axis of rotation. This process is called balancing. The machine component is then balanced and runs without vibration.

The TM 170 experimental unit can be used to demonstrate imbalance and the balancing process clearly. The difference between a static and a dynamic imbalance can be shown. Imbalance is determined and balanced by appropriate measures.

The main element of the experimental unit is a smooth shaft to which four variable imbalance masses are attached at any angular and longitudinal position. The shaft is mounted on ball bearings. It is driven by a variable-speed electric motor and a belt. The speed of the shaft is displayed digitally.

In order to determine the imbalance, a defined external moment is applied via an additional pulley with weights. This moment is compared to the moment of the imbalance masses. A transparent cover protects against contact with rotating parts and allows a clear view of the shaft. Unwanted vibrations are suppressed by using an elastic bearing for the foundation.

Learning objectives/experiments

- demonstration of imbalance vibrations at different speeds
- comparison of static, dynamic or general imbalance
- determine an imbalance
- perform a balancing operation

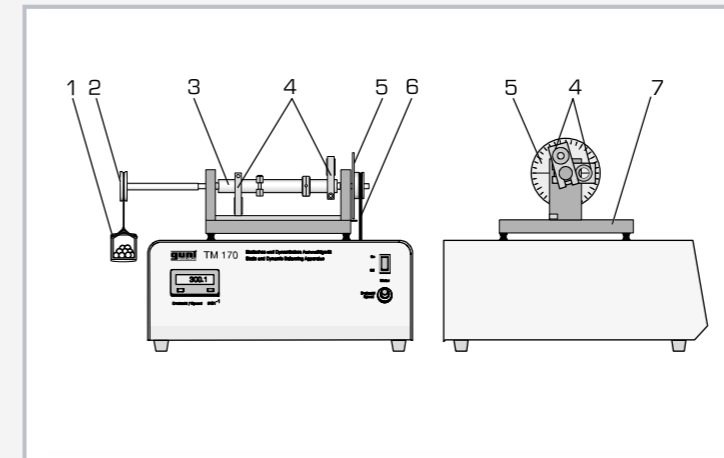

1 variable weight, 2 pulley, 3 shaft, 4 imbalance masses, 5 angular scale, 6 drive belt, 7 foundation with elastic bearing

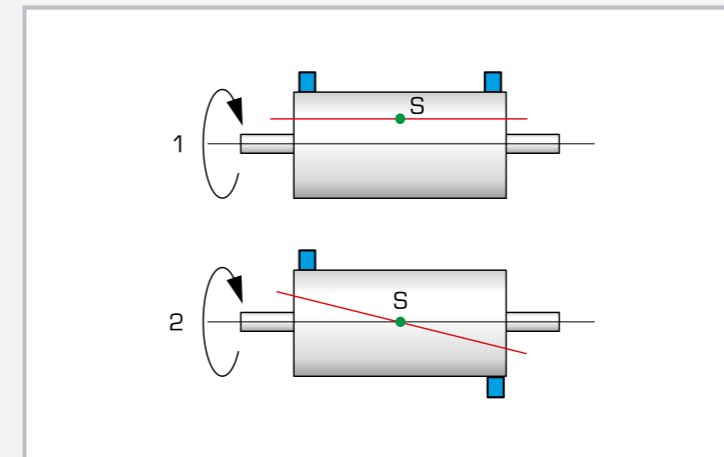

1 static imbalance, 2 dynamic imbalance; S centre of gravity; blue: mass distribution, red: principal axis of inertia

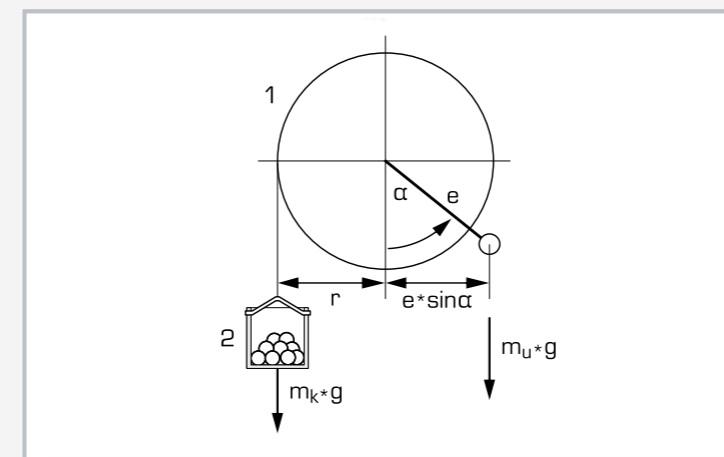

Determining imbalance:
1 pulley, 2 variable weight, r radius, e eccentricity, α angle of deflection, m_u mass of the imbalance, g gravitational acceleration, m_k mass of the variable weight

Specification

- [1] demonstration of static and dynamic imbalance
- [2] determine imbalance
- [3] processes involved in balancing
- [4] transparent protective cover for safe operation
- [5] foundation with elastic bearing
- [6] integrated angular and longitudinal scale
- [7] digital speed display

Technical data

Number of imbalance masses: 4
Max. total imbalance: 880cmg

Measuring ranges
■ speed: 0...1400min⁻¹

230V, 50Hz, 1 phase
230V, 60Hz, 1 phase; 120V, 60Hz, 1 phase
UL/CSA optional
LxWxH: 420x400x380mm
Weight: approx. 26kg

Scope of delivery

- 1 experimental unit
- 1 set of tools
- 1 set of weights
- 1 set of instructional material

PT 502

Field balancing



Description

- measurement of imbalance vibrations
- single and two-plane balancing

In rotating machines such as turbines or pumps, vibrations due to imbalance lead to comfort problems or even damage related to overloading. The imbalance of a rotating machine part may cause harmful vibrations in the entire machine. A familiar example is unbalanced tyres on a car. These cause annoying and unpleasant vibrations in the steering. This is why almost all rotating parts are balanced. If this balancing is done not on a particular machine but directly on the machine in operation located on-site, it is known as field balancing. Field balancing is done in four steps. In the first step, the vibrations are used to measure the initial imbalance. In the second step, additional known test imbalances are applied and the system is measured again. In the third step, the balancing is calculated from these two measurements and is applied. The fourth step is a control run to check whether the balancing has been successful.

The core of the PT 502 unit comprises two flywheels that are driven by an electric motor. Defined imbalances can be attached to the flywheels. At the foot of the motor are two acceleration sensors that measure the imbalance vibrations. The speed is measured by an optical speed sensor. The motor is mounted on the base plate with vibration-damping rubber elements. The unit is driven at variable speed by a frequency converter.

The measured values are transmitted directly to a PC via USB, where they can be analysed using the vibration analysis software that comes included. This analysis software has the following features: dual-channel oscilloscope for investigations in the time range, dual-channel spectrum analyser for investigations in the frequency range, vibration amplifier and balancing module for single and two-plane balancing.

Learning objectives/experiments

- measure and assess machine vibrations
- occurrence of imbalance vibrations
- static, dynamic or general imbalance
- dependence of imbalance vibration on position and magnitude of the imbalance
- basic principles of balancing
- field balancing in one plane
- field balancing in two planes
- assessment of balancing quality
- using a computerised vibration analyser

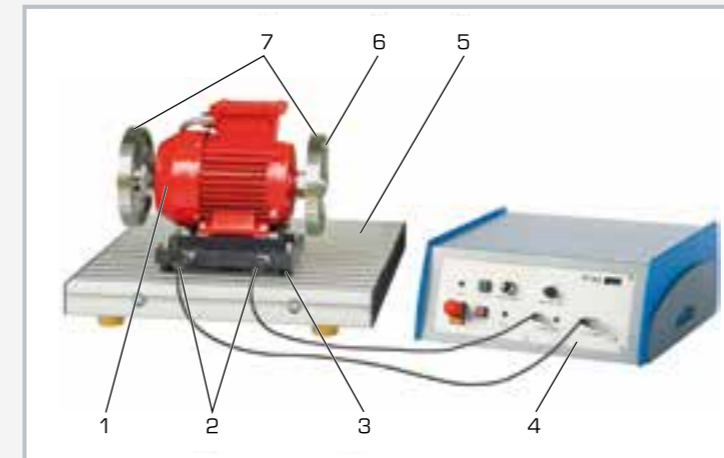

1 motor, 2 acceleration sensor, 3 elastic bearing, 4 control unit, 5 base plate, 6 balance mass, 7 flywheel

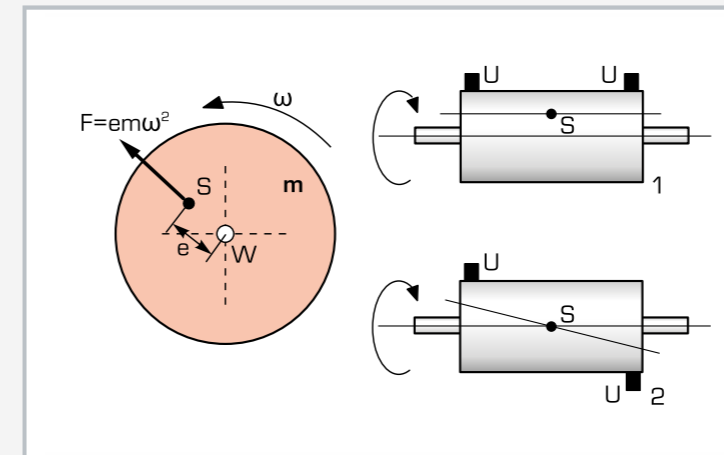

Left: imbalance force F due to eccentricity e of the centre of gravity S ; 1 static imbalance with eccentric centre of gravity, 2 dynamic imbalance with inclined inertial axis; m mass, U imbalance, W axis of rotation, ω angular velocity



Two-plane balancing using the GUNT software for vibration analysis

Specification

- [1] field balancing in one or two planes
- [2] 2 flywheels with mounting holes for imbalance or balance masses and angular division
- [3] imbalance or balance masses in different sizes
- [4] drive motor with variable speed via a frequency converter
- [5] elastic bearing of the drive motor
- [6] vibration isolation of the base plate using rubber feet
- [7] control unit with integrated measuring amplifier
- [8] instrumentation: optical speed sensor, 2 acceleration sensors for vibration measurement
- [9] software functions: dual-channel oscilloscope, dual-channel FFT analyser, ramp-up curve, order analysis and balancing
- [10] GUNT software for data acquisition via USB under Windows 7, 8.1, 10

Technical data

Flywheels

- 2x mass: 1,675kg
- radius for balance masses: 60mm
- angular division: 15°

Drive motor

- speed: 100...3000min⁻¹
- power: 370W

Imbalance or balance masses

- 2...10g
- max. total imbalance: 2x 42cmg

Acceleration sensors

- frequency range: 1...10000Hz
- sensitivity: 100mV/g
- resonant frequency: 32kHz

Optical speed sensor

- scan range: 3...150mm
- laser class II: 675nm

230V, 50Hz, 1 phase

230V, 60Hz, 1 phase; 120V, 60Hz, 1 phase

UL/CSA optional

LxWxH: 510x450x370mm (experimental unit)

LxWxH: 420x400x180mm (control unit)

Weight: approx. 25kg (total)

Required for operation

PC with Windows

Scope of delivery

- 1 experimental unit
- 1 control unit
- 1 set of accessories
- 1 GUNT software CD + USB cable
- 1 set of instructional material

TM 180**Forces in reciprocating engines****Description**

- investigation of free mass forces and moments of a reciprocating engine
- continuous adjustment of the angle between cranks
- simulation of single, two- or four-cylinder engines

Every reciprocating engine generates mass forces. The mass forces of the oscillating masses cannot be compensated completely, while the mass forces of the rotating masses are fully compensated. By using several cylinders it is possible that the forces compensate each other. However, disturbing moments may still occur.

The experimental unit TM 180 enables investigation of the free masses and moments of a reciprocating engine with a single cylinder, with two cylinders or with four cylinders.

The engine model comprises pistons with plastic slide bushes. The slide bushes do not require lubrication. For each cylinder, the angle between cranks can be adjusted continuously. As an aid, marks are provided at 0°, 90°, 180° and 270°.

The oscillating masses can be varied by using additional weights at the pistons. The four-throw crankshaft is driven by a DC motor and a synchronous belt. The speed is electronically controlled and digitally displayed. The free forces and moments are recorded by force sensors placed at the support of the model. All electronic functions are integrated in the display and control unit. The display and control unit also contains the USB interface for data acquisition.

The GUNT software enables the detailed evaluation of the signals of forces and moments.

Learning objectives/experiments

- effect of mass forces
 - ▶ mass forces in dependence on the speed
 - ▶ mass forces in dependence on the piston mass
 - ▶ first and second order mass forces
- comparison of different crank drives
 - ▶ 4-cylinder, symmetrical, 180° angle between cranks
 - ▶ 4-cylinder, non-symmetrical, 90° angle between cranks
 - ▶ 2-cylinder, 180° angle between cranks
 - ▶ single cylinder



1 piston, 2 cylinder, 3 crankshaft, 4 foundation plate, 5 display and control unit, 6 force sensor, 7 drive motor

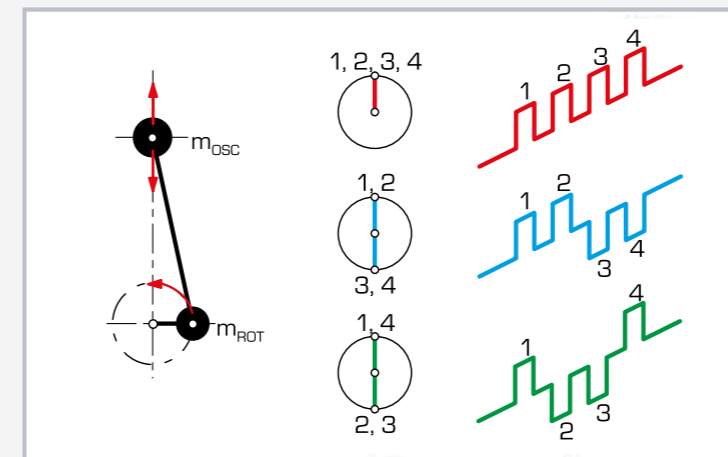

Left: definition of the rotating (m_{ROT}) and oscillating (m_{OSC}) masses at the crank drive, right: possible configurations of the crankshaft: red: single cylinder, blue: two-cylinder, green: four-cylinder

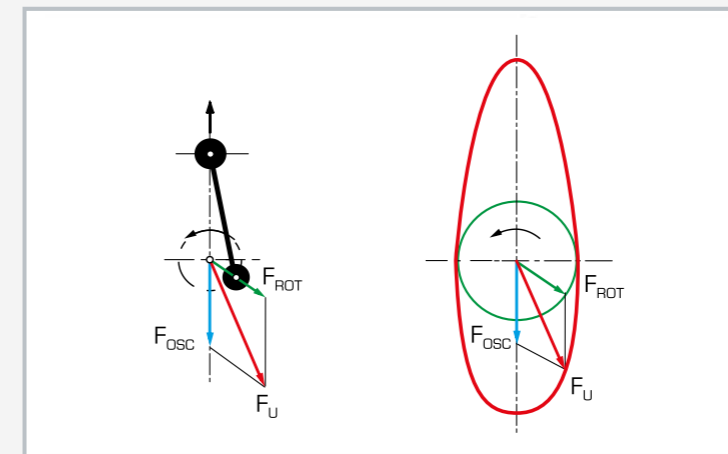

Left: effect of the oscillating (blue, F_{OSC}) and the rotating (green, F_{ROT}) mass forces and their vectorial addition to the free mass force (red, F_U). Right: mass forces course during a crankshaft revolution

Specification

- [1] experimental unit to investigate oscillating and rotating mass forces and moments of a reciprocating engine with up to 4 cylinders
- [2] simulation of single, 2- or 4-cylinder engines
- [3] electronically commutated and speed-controlled drive motor with digital speed display
- [4] continuous adjustment of the angle between cranks
- [5] force sensors to measure forces and moments
- [6] vibration isolation using rubber elements and suitable tuning
- [7] GUNT software for data acquisition via USB under Windows 7, 8.1, 10

Technical data**Engine**

- number of cylinders: 4
- piston mass: 40g
- additional mass: 41g

Crank drive

- mass of connecting rod: 18g
- centre distance of cylinders: 35mm
- crank radius: 15mm
- length of connecting rod: 70mm

Measuring ranges

- speed: 100...3000min⁻¹
- force: 0...500N

230V, 50Hz, 1 phase
230V, 60Hz, 1 phase; 120V, 60Hz, 1 phase
UL/CSA optional
LxWxH: 420x370x350mm
Weight: approx. 40kg
LxWxH: 230x230x80mm (display and control unit)
Weight: approx. 1kg

Required for operation

PC with Windows

Scope of delivery

- 1 engine model
- 1 display and control unit
- 1 set of accessories (tools, additional masses)
- 1 GUNT software CD + USB cable
- 1 set of instructional material

GL 112

Investigation of cam mechanisms



Description

- record elevation curves of cam mechanisms
- four different cam members, two different engaging members
- influence of spring stiffness and mass on the dynamic behaviour

Cam mechanisms play an important role in the conversion of rotary motion into oscillatory motion. The most common application of cam mechanisms is the activation of valves in engines. This application is highly dynamic: valves must be opened and closed in very quick succession. The contact between the valve and a cam must not be lost, otherwise it would result in uncontrolled oscillations, valve float and possible damage to the engine.

The GL 112 experimental unit allows the dynamic investigation of a cam mechanism at various speeds. Four typical cams with corresponding engaging members are compared in terms of their motion behaviour. The valve is simulated with a mass and a spring.

By varying the spring stiffness, spring preload and oscillating mass, it is possible to study the dynamic limits of the respective cams. The cam motions and valve raising can be clearly demonstrated using a stroboscope (not included).

A recorder synchronised with the cam member records the actual elevation curve of the cam mechanism. A speed-controlled drive motor with a large flywheel generates a speed as constant as possible. The open design means that the motion is clearly visible in every detail.

A transparent protective cover ensures safe operation. The experimental unit is intended for demonstration in engineering education. It is not suitable to be used as a test bench in the field of endurance testing/tribology.

Learning objectives/experiments

- elevation curves in non-matching engaging member
- elevation curve in sprung-engaging member
- determine the limit speed and compare with theory
- influence of moving mass on the motion of cam member/plunger
- influence of return-spring stiffness and preload on the motion of cam member/plunger
- comparison of the elevation curves of different cam-member shapes
- comparison of elevation curves with theory

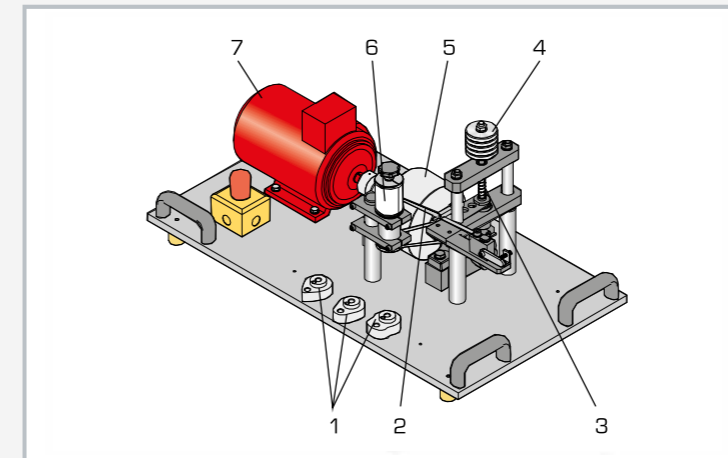

1 interchangeable cam-shaped cam member, 2 nib, 3 spring, 4 mass disks, 5 flywheel, 6 recorder drum, 7 drive motor

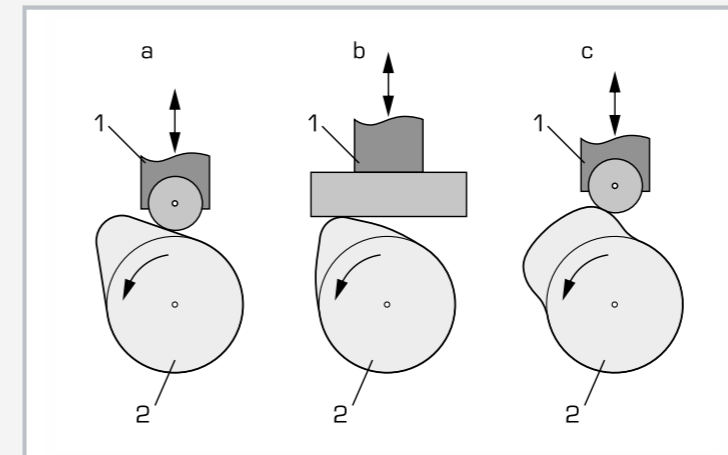

1 engaging member (rolling receiver with plunger / flat receiver with plunger), 2 cam-shaped cam member; a tangent cam with roller plunger, b circular arc cam with flat plunger, c hollow cam with roller plunger

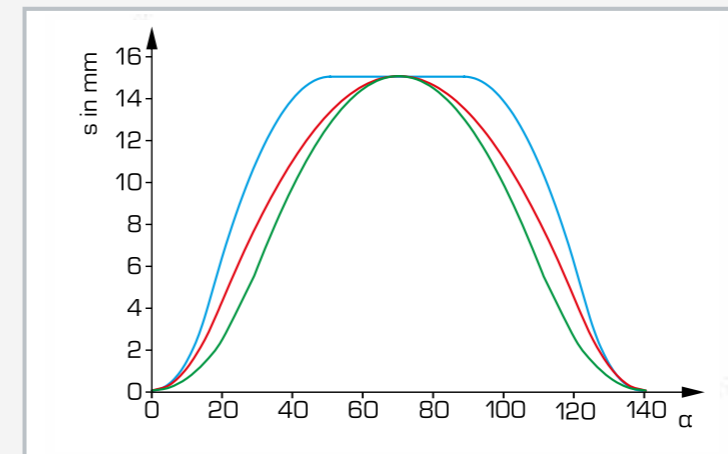

Elevation curves; s stroke, α opening angle; blue: hollow cam, red: circular arc cam, green: tangent cam

Specification

- [1] investigation of cam mechanisms
- [2] cam-shaped cam members: tangent cam, hollow cam, 2 circular arm cams with different head radius
- [3] 2 different engaging members: flat receiver with plunger or rolling receiver with plunger
- [4] 3 interchangeable return springs and spring preload
- [5] drive motor with variable speed
- [6] oscillating mass can be increased with 5 additional weights
- [7] mechanical drum recorder with nib and coated paper
- [8] optical speed sensor
- [9] transparent protective cover for safe operation

Technical data

- Drive motor
- DC asynchronous motor with frequency converter
 - power: 250W
 - speed: 60...670min⁻¹

- Cam-shaped cam member
- stroke, each: 15mm
 - opening angle, each: 140°

- Spring stiffness
- hard: 5,026N/m
 - medium: 2,601N/m
 - soft: 613N/m

- Masses
- additional weight: 200g
 - plunger: 530g
 - flat receiver: 93g
 - rolling receiver: 20g

Recorder: toothed belt drive

230V, 50Hz, 1 phase
230V, 60Hz, 1 phase; 120V, 60Hz, 1 phase
UL/CSA optional
LxWxH: 800x440x440mm (experimental unit)
Weight: approx. 40kg
LxWxH: 360x320x160mm (display and control unit)
Weight: approx. 5kg

Scope of delivery

- 1 experimental unit
- 1 display and control unit
- 4 cam-shaped cam members
- 2 engaging members
- 3 return springs
- 3 blocks of recorder paper
- 1 set of tools
- 1 set of instructional material

TM 182

Vibrations on machine foundations



Description

■ vibrations generated via imbalance

An indispensable part of machine design is the reduction of vibrations. For example, an elastic, vibration-isolating setup of the machine avoids disruptive vibrations being transferred to the surroundings.

The TM 182 unit can be used to study the issue of machine foundations and isolation from vibrations using a practical example. To do this, vibrations are deliberately produced on an elastically mounted machine. The transfer of these vibrations to the foundation is measured. It is then possible to test different adjustments using different springs and to study absorbing effects using vibration absorbers.

The experimental setup consists of a machine, a foundation and a frame. A vibration generator serves as the machine, consisting of two independently driven imbalance sets. The imbalance sets are driven by servomotors so that any excitation forces and force directions can be generated. Alternatively, a piston compressor (TM 182.01) can be used to generate vibrations.

The machine is mounted on a foundation by means of springs and dampers. The surroundings are represented by the foundation, on which the effectiveness of the vibration isolation is measured.

The foundation is connected to the actual frame of the trainer via additional coil springs. This dual vibration isolation, together with the large weight of the foundation itself, guarantees a vibration-free operation in the laboratory even under unfavourable experimental conditions. A switch cabinet is attached to the frame, housing the control system, power supply and data acquisition.

Acceleration sensors are used to measure deflection, velocity and acceleration of the vibrations at different points. Using these measured values, it is possible to calculate and display the operational vibration modes.

A comprehensive software program is provided to control the operating conditions and to capture and analyse the data. The unit is connected to the PC via USB.

Learning objectives/experiments

- familiarisation with vibration phenomena on machine foundations
- adjust the foundation for different excitation forces
- investigate vibration absorbers
- investigate the effect of additional damping
- compare metal springs and rubber springs
- measure and analyse vibrations
- determine operational vibration modes

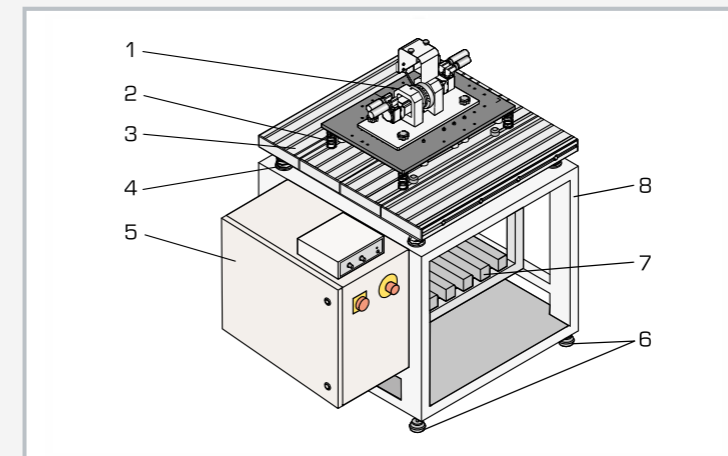

1 vibration generator as machine, 2 coil spring, 3 foundation, 4 coil spring, 5 switch cabinet, 6 elastic support, 7 extra masses for the foundation, 8 frame

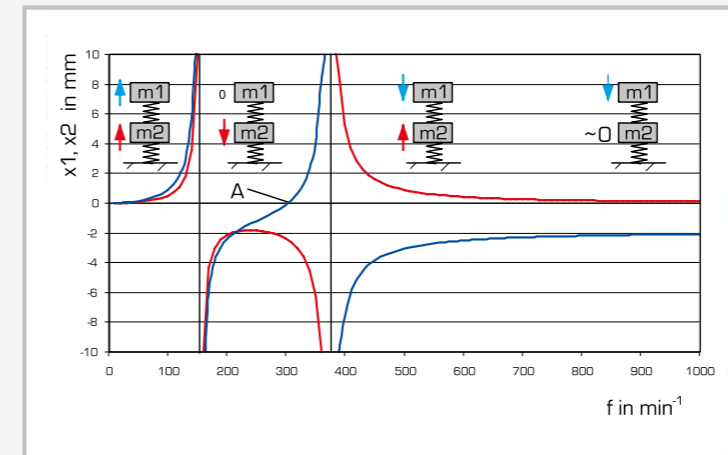

Amplitude-frequency response at unbalance excitation and effect of vibration absorbers m: mass, blue amplitude x1: mass 1, red amplitude x2: mass 2, A: absorption point

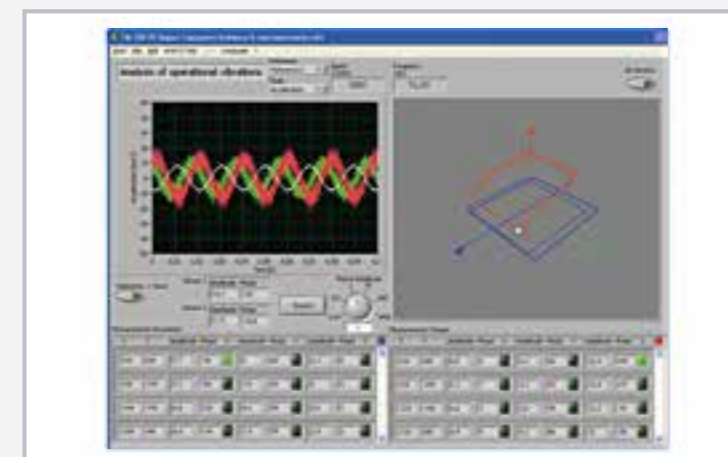

Software screenshot: measurement and representation of operational vibration mode

Specification

- [1] display and study vibrations on machine foundations
- [2] vibration generator excites vibrations by imbalance
- [3] vibration-free laboratory operation thanks to additional vibration isolation of the foundation
- [4] 2 brushless high-performance servomotors to drive the vibration generator
- [5] eccentricity, rotational frequency, direction of rotation, adjustable phase position and frequency ratio
- [6] variable arrangement of vibration absorbers
- [7] vibration measurement via acceleration sensors
- [8] inductive displacement sensor records the eccentricity of the imbalance masses
- [9] GUNT software with control functions and data acquisition via USB under Windows 7, 8.1, 10
- [10] TM 182.01 piston compressor can be used as alternative "real" vibration generator

Technical data

Drive motors

- max. speed: 6000min⁻¹
- max. torque: approx. 3,40Nm

"Machine" mounted on a plate

- mass: max. 26kg (incl. extra weights 4x 2kg)
- max. imbalance: 2x 500cmg
- max. imbalance force: 2x 500N (up to 3000min⁻¹)

Foundation

- mass: max. 73kg (incl. extra weights 5x 9,4kg)
- min. natural frequency: 2,66Hz

Compression springs

- spring stiffness C: 2,44N/mm...139,53N/mm
- transverse stiffness Cq: 0,30N/mm...90,0N/mm

Measuring ranges

- acceleration: 490m/s²

230V, 50Hz, 1 phase
 230V, 60Hz, 1 phase; 230V, 60Hz, 3 phases
 UL/CSA optional
 LxWxH: 1140x800x1170mm
 Weight: approx. 311kg

Required for operation

PC with Windows

Scope of delivery

- 1 trainer
- 1 vibration generator
- 1 GUNT software CD + USB cable
- 1 set of instructional material

TM 182.01**Piston compressor for TM 182****Learning objectives/experiments**

- in conjunction with trainer TM 182:
 - ▶ generating vibrations on machine foundations with a "real machine"

Specification

- [1] air-cooled single cylinder piston compressor for installation in trainer TM 182
- [2] compressor as vibration generator
- [3] vibration generator simulates machine vibrations
- [4] speed adjustable using frequency converter

Technical data

Air-cooled single cylinder compressor with frequency converter

- mass: 16kg
- speed: 500...1800min⁻¹

230V, 50Hz, 1 phase
 230V, 60Hz, 1 phase
 120V, 60Hz, 1 phase
 UL/CSA optional
 LxWxH: 420x300x300mm
 Weight: approx. 22kg

Scope of delivery

- 1 piston compressor with frequency converter
- 1 manual

Description

- as a "real machine", the piston compressor generates vibrations for the trainer TM 182

A piston compressor is a typical machine, on which imbalance and oscillating masses generate vibrations. Balancing the "machine" does not adequately reduce these vibrations. In this case, a vibration isolating machine foundation helps to avoid unwanted vibrations from being transmitted to the surroundings.

The TM 182.01 compressor is used as a model of a "real machine" for the trainer TM 182. The compressor is only used here as a "machine" that generates vibrations on the foundation. The compressed air generation function is not used.

The TM 182.01 is available as a complete assembly and consists of a single cylinder compressor with integrated motor. To generate vibrations with different frequencies, the compressor is fitted with a frequency converter.

Installation and commissioning



Guaranteed trouble-free by professional GUNT staff

Have your new equipment commissioned by trained expert personnel. Our highly qualified staff will gladly assist you.

Commissioning of the equipment includes the following services:

- setup of equipment in the laboratory
- connection to the laboratory's supply systems
- commissioning the equipment
- testing the equipment

Machinery diagnosis

The aim of machinery diagnosis, also known as machinery status monitoring or condition monitoring system (CMS), is to conduct needs-based maintenance or repair and therefore to minimise the repair and downtimes of a machine. Damage should be

detected when it occurs. This increases the overall equipment effectiveness (OEE), a measure of the added value of a plant, and optimises the cost structure.

What characterises the condition of a machine?

The following are some measurable state variables using the example of a diesel generator:

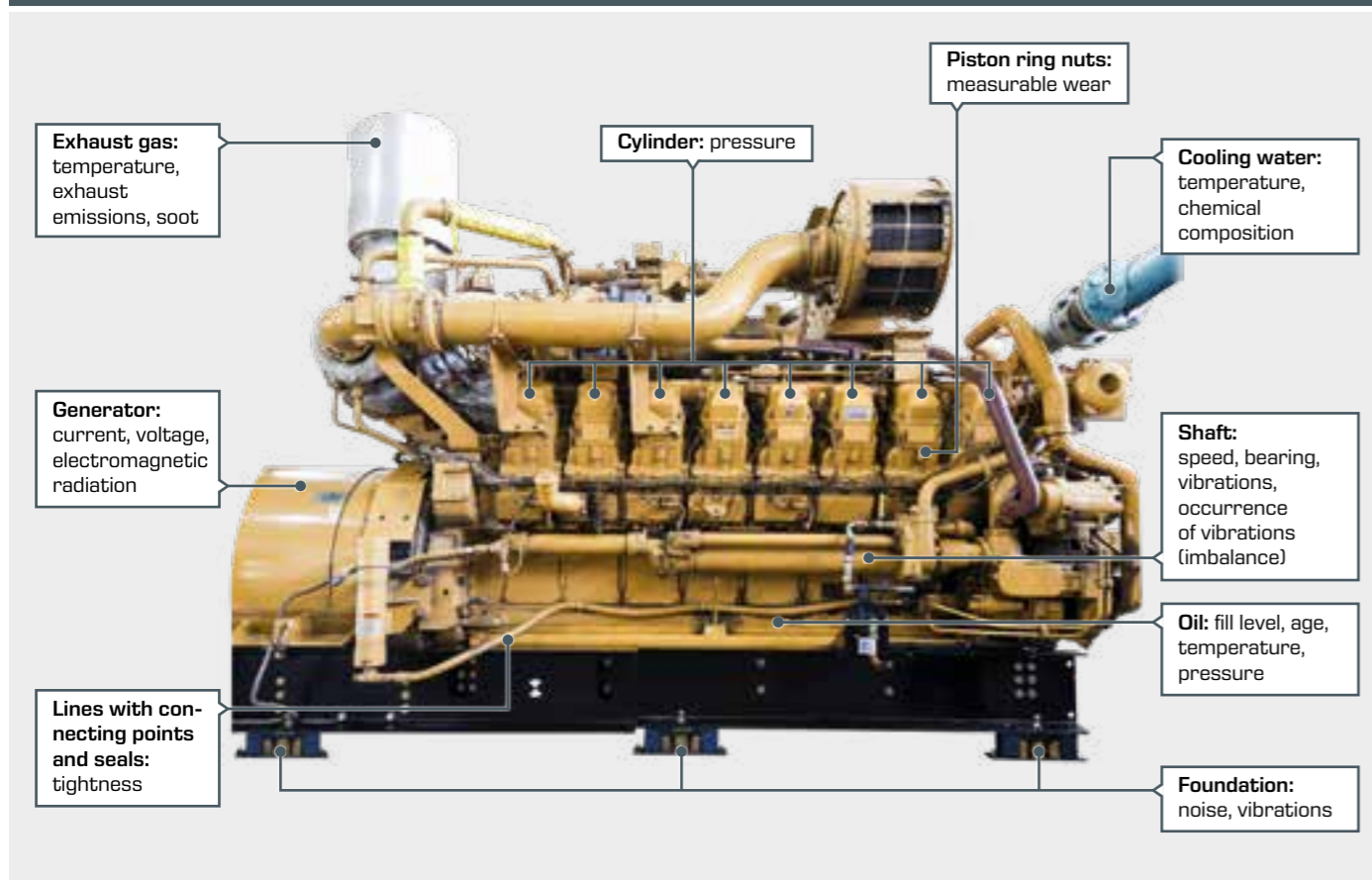

Machinery diagnosis is used for

- weak-point analysis to optimise a process or to detect expected errors in good time
- condition-based maintenance, e.g. the use of car tyres when these fail to meet the prescribed minimum tread depth
- avoid or minimise failures thanks to pre-determined maintenance, e.g. oil change in motor vehicle at a fixed interval or after a certain mileage

Machinery diagnosis is conducted on

machines at standstill by:

- disassembly and visual inspection
- wear measurement
- crack testing (X-rays, ultrasound, magnetic penetration, natural frequency measurement)

Machinery diagnosis leads to

- increased and optimum use of the lifecycle of plant and machinery
- improved operational safety
- increased plant reliability
- optimised operating processes
- reduced disturbances
- reduced costs

running machines by:

- measuring the state variables, e.g. vibration measurement
- acoustic measurement
- extension of the shaft
- lubricant analysis

The significance of vibrations in machinery diagnosis

The mechanical condition of a machine or its parts can be assessed by the nature and extent of the vibrations produced. To do this, vibrations are recorded and analysed by sensors and measuring instruments. The correct interpretation of the

measuring signals requires a good understanding of the operating mechanisms and a certain amount of experience.

Causes of vibration	Examples from practice for remedy
1. Circumferential or periodic forces from <ul style="list-style-type: none"> ■ pressing or punching ■ jamming, alignment errors 	 <p>Elastic vibration-damping mount of the machine to prevent / minimise propagation of the vibration.</p>
2. Inertial forces due to rotating and oscillating masses <ul style="list-style-type: none"> ■ reciprocating pistons ■ rotating imbalances 	 <p>Tyres are balanced to correct imbalances.</p>
3. Plungers <ul style="list-style-type: none"> ■ play in the contact points and thereby changing contact surfaces in positive force transmission ■ contact loss in the case of non-positive force transmission ■ rolling over faults in the surface 	 <p>Preloaded bearings make it possible to align the shaft precisely, increase the rigidity and reduce the bearing clearance.</p>  <p>Good lubrication must be provided to minimise damage to the gears and to prevent the occurrence of fault points in the surface.</p>
4. Gas forces <ul style="list-style-type: none"> ■ expansion due to the build up of dynamic gas forces and excitation of longitudinal and bending vibrations ■ non-uniform rotation and excitation of torsional vibrations 	 <p>Forces occur in the crankcase from the transmission of gas forces from the cylinder head to the crankshaft bearing. Stiffened crankcase and expanding screws avoid vibrations and fatigue in the material.</p>
5. Flow forces <ul style="list-style-type: none"> ■ surfaces are excited by turbulence, with associated pressure fluctuations in the form of positive surge waves (howling, noise, whistling); this is the opposite of sound radiation ■ periodic flow forces on blades 	 <p>When designing rotors, such as those for fans and compressors, the number and shape of the rotors must be taken into account relation to of the possible occurrence of vibrations.</p>
6. Electromagnetic forces <ul style="list-style-type: none"> ■ dynamic magnetic fields or cyclical changes in the geometry (pole faces) ■ similarity to excitation via pressure fluctuations (transformer hum, stator vibrations in engines) 	 <p>Asynchronous motor: In an asymmetrical air gap, the circulating magnetic forces cause torsional and bending vibrations. By varying the air gap between stator and rotor, it is possible to change the mechanical vibrations that are produced.</p>

Machinery diagnosis

Methods of machinery diagnosis

Internal forces and **energies** of the machine are of real interest for machine diagnostics. These variables cannot be measured directly, but their effects – **vibration** – can. Vibration measurement and analysis allows a picture of these forces to be obtained. We can see the structure of the forces, their causes and their behaviour over time from the vibration measurements. The measuring signals are mostly frequency spectra, which arise from superposition of various vibrations with different frequencies. Some of these vibrations are part of the

proper normal operation of the machine, others are amplified or produced by defects. By interpreting the measuring signals, we can assess the condition of the machine and identify defects.

In machinery diagnosis we differentiate between **characteristic-value monitoring** and **frequency analysis**.

In **characteristic-value monitoring**, the amplitude of the measured vibration signal is compared to a limit value. Characteristic-value monitoring can be performed continuously and automatically. It is easy to implement and its use requires relatively little expertise. One widely applied characteristic value is the effective value of the velocity of the vibration in the frequency range of 10 – 1000 Hz. This is used in the DIN ISO 10816-3 standard, that relates to drive systems. In simple standard units, characteristic-value monitoring is sufficient for diagnostics. In more complex systems, the reliability of this method is sometimes not sufficient.

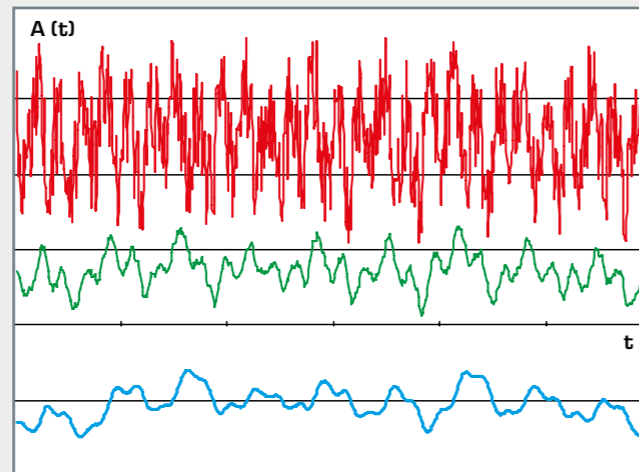

Typical vibration signals in the time domain

— Acceleration
— Velocity
— Path

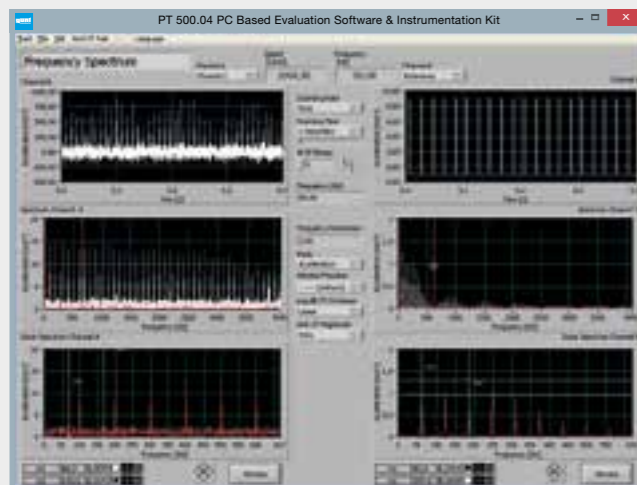

The use of the **analysis in the frequency domain** is considerably more complex but also more powerful. The analysis makes it possible to identify the nature of damage. Consequently, repair measures can be implemented effectively. Frequency analysis requires a good understanding of the mechanisms of action and sufficient experience in interpreting the results. Usually, frequency analysis is used as a complementary method in conjunction with characteristic-value monitoring.

Learning objectives

Mechanical vibrations	Causes, mechanisms of occurrence, imbalance, Laval rotor, resonance, damping, shock
Vibration measuring methods	Measuring sensor, measuring amplifier, representation, oscilloscope, speed measurement
Vibration analysis	Acceleration, vibration velocity, vibration path, characteristics, representation in time and frequency domain, spectrum, FFT (Fast Fourier Transformation), orders, tracking analysis, envelope analysis, orbit, trajectory
Machinery diagnosis	Bearing and shaft vibrations, permissible vibration levels, roller bearing damage, electromagnetic vibrations, imbalance vibrations and balancing, gear damage, vibrations on belt drives, cavitation in pumps, blade oscillations, vibrations and shocks in crank mechanisms, speed-dependent vibrations

Furthermore, practical skills and experience are taught for dealing with and assembling machine elements such as bearings, shafts and couplings. The structure of mechanical machines can also be studied.

Questions provide valuable experience for future industrial practice:

- Which sensor should I use?
- Where can I expect a usable measuring signal?
- How do I remove interference effectively?

Damage on drive elements using the example of bearings



Indicators of damage to drive elements include:

- deposits on the running surfaces, e.g. fretting corrosion in the bore of an inner ring
- corrosion due to moisture and bearing standstill
- surface distress in the form of pitting
- bearing damage caused by slip
- cracks or fractures

If the first signs of damage to the machine are ignored, the damage increases and can lead to fracture.

Machinery diagnosis

Typical experimental results in machine diagnosis

1. Identification of bearing damage

Envelope analysis

Envelope analysis is used to identify, for example, damage to roller bearings and gears. The damage produces shocks with very-high-frequency vibration components. The low shock frequency that is relevant for diagnosing damage can be identified

in a normal spectrum only with difficulty, or may even be impossible to identify. Envelope analysis demodulates the high-frequency shock signal and allows the shock frequency to be measured.

Process of envelope analysis

Measurement of high-frequency shock signal and high-pass filtering to suppress low-frequency interference (imbalance, alignment errors)



Rectification of the high-frequency signal



Envelope of the rectified signal by low-pass filtering

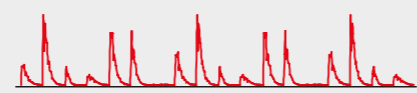

Conduct FFT to obtain spectrum of the envelope. The speed (10 Hz) and the shock frequency (35,8 Hz) can be seen clearly. The sidebands spaced at the speed (35,8 -10, 35,8 +10) indicate an amplitude modulation. This is evidence of damage to the outer ring with rotating load.

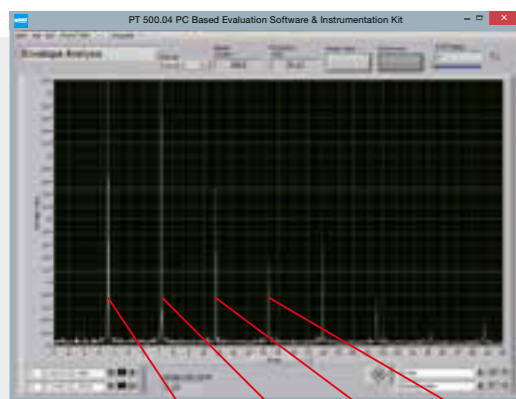
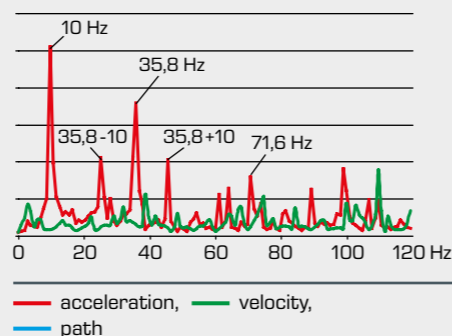

Orders: 3,58 7,16 10,74 14,32

The illustration shows the envelope spectrum of typical bearing damage. To obtain a display that is independent of rotation frequency, the order was chosen as the abscissa. A rotational frequency signal is of the first order. Frequency lines are read in multiple of the order 3,58. This indicates damage to the outer ring of the bearing. The absence of first-order sidebands indicates a constant force direction, i.e. belt tension in this case, and no rotating imbalanced load.

2. Field balancing

In balancing we try to bring the centre of gravity of the rotor back in line with the axis of rotation. To do this, weights are added to or removed from the rotor. In order to determine the position and size of the required balancing masses, it is first necessary to

determine the unknown imbalance. Since the imbalance cannot be measured directly, it must be determined indirectly from the measurable bearing vibrations.

Measurement of the bearing vibrations of the out-of-balance machine (original imbalance **U**).

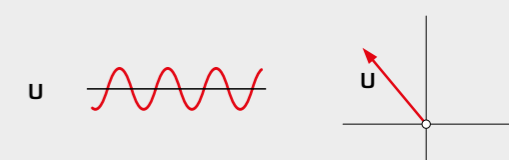

Measurement of bearing vibrations according to which known imbalance was added to the machine (test imbalance **T**). It is possible to calculate the original imbalance by comparing of the two measurements.

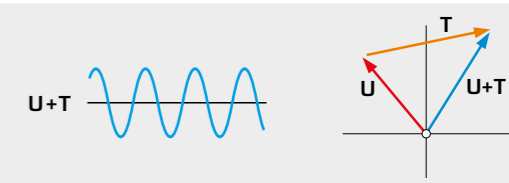

Calculation of the size and position of the balancing masses (**C**) to be added or removed. Control measurement (**A**) after performing mass correction. Depending on the success of balancing, this procedure is repeated until the desired limit value of the bearing vibration is met.

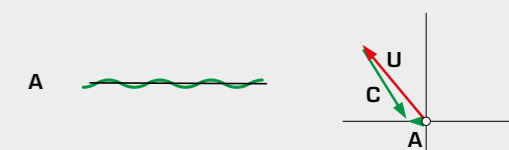

3. Identification of cracks in shafts

Shafts with cracks produce a characteristic vibration signal that can be used to identify the crack. One analysis method is **tracking analysis**, in which the vibration signal is recorded over

a large speed range and studied in a special filter for different orders of rotation-frequency.

Graph A shows the component of the first-order bearing vibration (1Ω), graph B shows the component of the second order (2Ω).

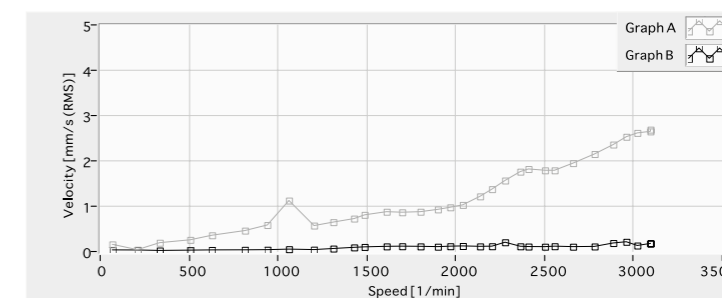

Tracking analysis shaft without crack

Condition without crack:

The first-order bearing vibrations increase normally with speed because of the imbalance. The second-order bearing vibrations are very small.

Condition with deep crack:

Whereas the first-order bearing vibrations show behaviour similar to a shaft without a crack, there is a very sharp rise in the second-order vibrations in the medium speed range, which is a strong indication of a crack.

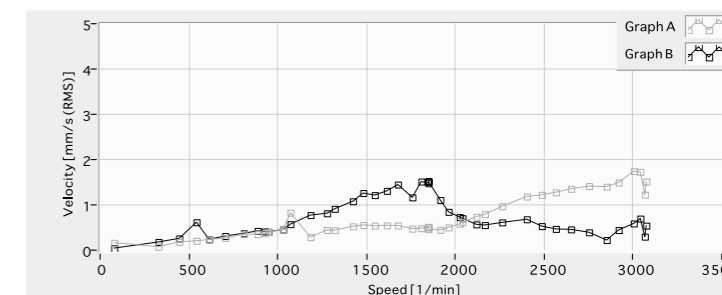

Tracking analysis shaft with crack

PT 501

Roller bearing faults



Description

- assessment of bearing condition by vibration analysis
- comparison of bearings with different faults

Vibration analysis is a key tool in estimating the condition of a roller bearing. The slow change in the vibration spectrum provides indications of the remaining life of a bearing and can be used as a criterion for its replacement. The spectral distribution can deliver accurate information on the type and location of the damage.

PT 501 contains six interchangeable roller bearings on which different faults can be detected and explained. The radial load on the bearing is set within broad limits using the loading device.

An electric motor with variable speed via frequency converter is used as drive. An acceleration sensor with measuring amplifier serves to measure the vibrations at the bearing housing. The speed is measured with an optical sensor.

The measured values are transmitted directly to a PC via USB. The software for vibration analysis is included. The analysis software offers the following features: two-channel oscilloscope for investigations in the time range; two-channel spectrum analyser for investigations in the frequency range; vibration measuring unit; envelope analysis for bump effects and roller bearing damage.

Learning objectives/experiments

- vibrational spectrum of the running noise of roller bearings
- familiarisation with the envelope analysis
- influence of damage to outer race, inner race or roller body, on the spectrum
- estimating service lives of roller bearings
- influence of the lubricant on the vibration spectrum
- detection of faulty roller bearings
- use of a computerised vibration analyser

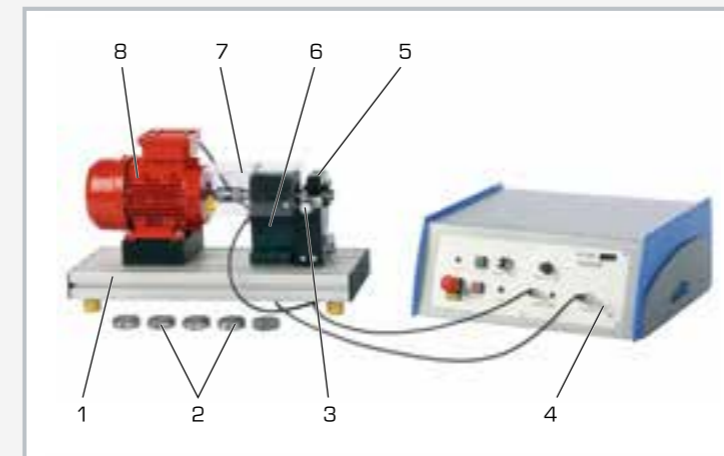

1 foundation plate, 2 roller bearing, 3 loading device, 4 control unit, 5 mounting for roller bearing to be studied, 6 bearing of the shaft, 7 transparent cover, 8 motor

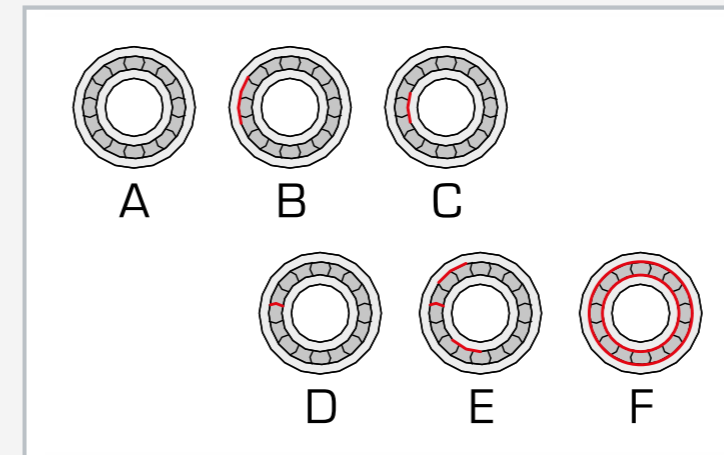

A) undamaged bearing, B) bearing with damage to outer race, C) bearing with damage to inner race, D) bearing with damage to a roller body, E) bearing with damage to roller body, outer and inner race, F) heavily worn bearing

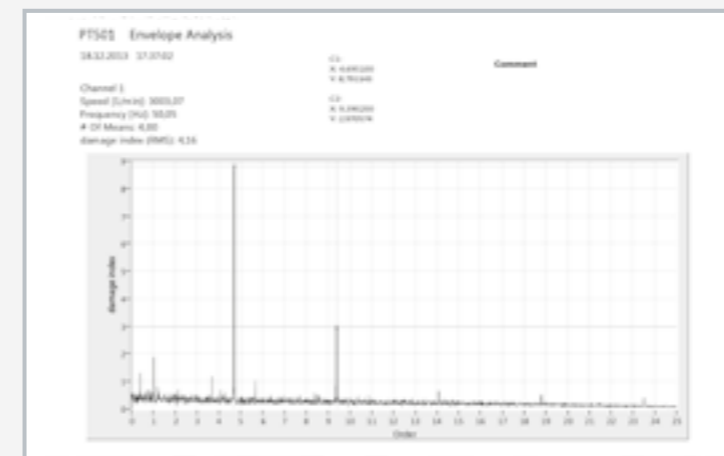

Envelope analysis of the bearing with damage on outer ring (B) at $f=3000\text{min}^{-1}$

Specification

- [1] investigation of the vibrations of roller bearings
- [2] roller bearing with damage to outer race
- [3] roller bearing with damage to inner race
- [4] roller bearing with damage to a roller body
- [5] roller bearings with combined damage
- [6] long-running roller bearings
- [7] new and undamaged roller bearing
- [8] drive motor with variable speed via frequency converter
- [9] radial loading of bearings via adjustable loading device
- [10] vibration isolation of the foundation plate using rubber elements
- [11] instruments: optical speed sensor, acceleration sensor to record vibration
- [12] software features: 2-channel oscilloscope; 2-channel FFT analyser; envelope analysis; run-up curve and order analysis
- [13] GUNT software for vibration analysis under Windows 7, 8.1, 10

Technical data

Pendulum ball bearing of type NU204-E-TVP2

- inside diameter: $\varnothing=20\text{mm}$
- outside diameter: $\varnothing=47\text{mm}$
- width: 14mm
- number of rollers: 12

Drive motor

- speed: $100\text{...}3000\text{min}^{-1}$
- power: 370W

Acceleration sensor

- frequency range: $1\text{...}10000\text{Hz}$
- sensitivity: 100mV/g
- resonance frequency: 32kHz

Optical speed sensor

- sampling width: $3\text{...}150\text{mm}$
- laser class II, 675nm

230V, 50Hz, 1 phase

230V, 60Hz, 1 phase; 120V, 60Hz, 1 phase

LxWxH: $510\times 200\times 330\text{mm}$ (experimental unit)

LxWxH: $420\times 400\times 180\text{mm}$ (control unit)

Weight: approx. 25kg (total)

Required for operation

PC with Windows

Scope of delivery

- 1 experimental unit
- 1 control unit
- 6 roller bearings
- 1 set of accessories
- 1 GUNT software CD + USB cable
- 1 set of instructional material

PT 500 Machinery diagnostic system

The condition of a machine or its parts can be assessed by the nature and extent of the vibrations produced. To do this, vibrations are recorded and analysed by sensors and measuring instruments. The correct interpretation of the measuring signals requires a good understanding of the acting mechanisms and a certain amount of experience.

The PT 500 system from GUNT is a modular training system that addresses these complex issues in engineering education and studies them by experimentation. Using the PT 500 machinery-diagnostic teaching system, you can simulate, measure and evaluate vibration signals of typical malfunctions and damage. The interpretation of measuring signals can be practised extensively.

Professional measuring technology allows the experience gained to be transferred into day-to-day operation.

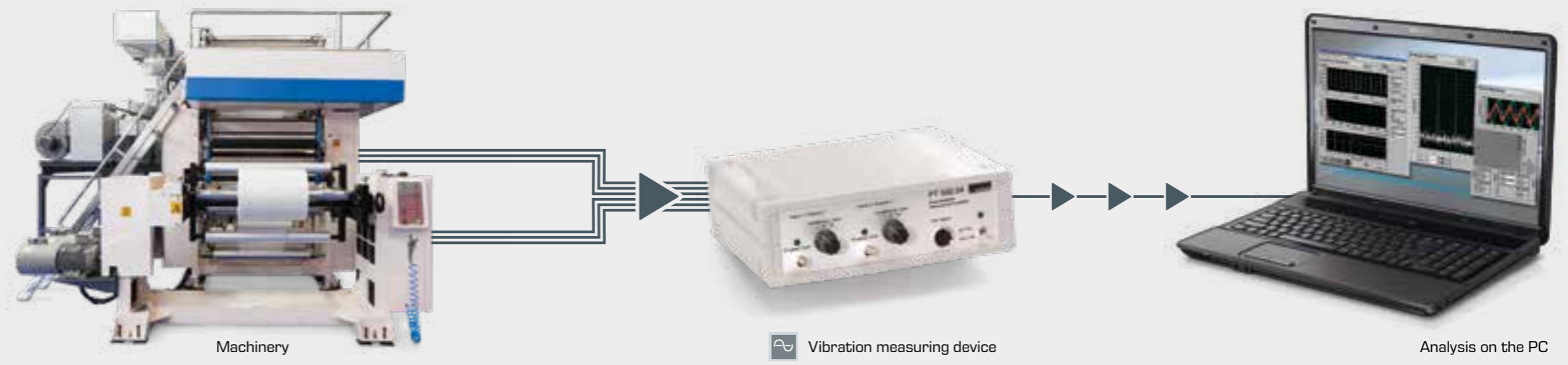





A complete summary of all options of the modular system can be found in our PT 500 brochure, which is available for download at www.gunt.de.

The core element of the training system is the PT 500 base unit. The components of the base unit, together with the PT 500.04 computerised vibration analyser, allow a series of experiments on the topic of machinery diagnostics. In addition, the PT 500.10 – PT 500.19 accessory sets are available to simulate different, reproducible types of damage. In addition to pure measuring exercises on vibration measurement (measuring deflection, velocity and acceleration of the vibration in the time or frequency domain), it is possible to practice field balancing on rigid rotors and the alignment of shafts. Almost any topic in machinery diagnostics can be covered thanks to a wide range of accessories.

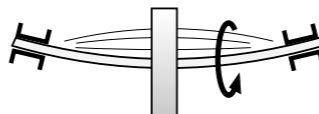
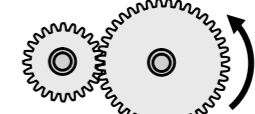
The base unit contains a vibration-damped fixing plate, a speed-controlled drive motor with a tachometer, a shaft with two mass disks and two bearing units, a coupling and balancing weights.

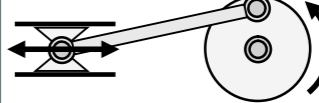
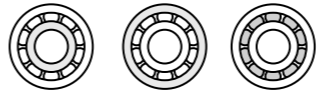
Accessories that can be connected to the base unit

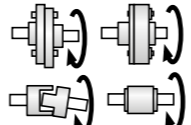
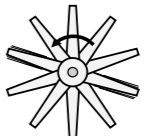
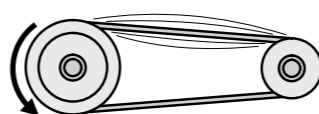
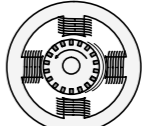
<p>PT 500.10 Elastic shaft kit</p>  <p>Imbalance vibrations of a flexurally elastic shaft, resonance, critical speed, balancing</p>	<p>PT 500.15 Damage to gears kit</p>  <p>Identification of gear damage from the vibration signal, influence of tooth type and lubrication</p>
<p>PT 500.11 Crack detection in rotating shaft kit</p>  <p>Vibration behaviour of a cracked shaft, identification of the crack from the vibration signal</p>	<p>PT 500.16 Crank mechanism kit</p>  <p>Vibrations in crank mechanisms, free inertia forces, impacts and shocks due to bearing clearance and wear</p>
<p>PT 500.12 Roller bearing faults kit</p>  <p>Identification of bearing damage from the running noise, different pre-damaged roller bearings included</p>	<p>PT 500.17 Cavitation in pumps kit</p>  <p>Noise and damage due to cavitation, conditions for cavitation</p>
<p>PT 500.13 Couplings kit</p>  <p>Properties of different coupling types, influence of axial and radial runout and pitch error on vibration behaviour</p>	<p>PT 500.18 Vibrations in fans kit</p>  <p>Vibrations in fans, demonstration of vibration excitation by blade passage, influence of gyroscopic effect</p>
<p>PT 500.14 Belt drive kit</p>  <p>Vibrations on belt drives, resonance and critical speeds, influence of belt tension, radial runout and alignment</p>	<p>PT 500.19 Electromechanical vibrations kit</p>  <p>Interaction in an electro-magnetic-mechanical system, influence of load, air gap geometry and electrical asymmetry</p>

PT 500

Machinery diagnostic system, base unit



The illustration shows the base system PT 500 ready for conducting experiments, together with the trolley PT 500.01.

Description

- **base unit for setting up wide ranging experiments in machinery diagnostics using modular accessory sets**
- **aluminium base plate with slots for quick, flexible assembly of different experimental setups**

In order to avoid serious damage to machines and to carry out maintenance on time, the condition of the machine must be known. The state of a machine or machine parts can generally be judged well in terms of the type and size of its vibrations. The machinery diagnostic system can be used to simulate certain types of damage and investigate its effects on the vibration spectrum.

The PT 500 base unit permits vibration measuring exercises (measurement of vibration displacement, velocity and acceleration in the time/frequency range). Field balancing of rigid rotors and alignment of shafts can also be practiced.

The key components of the base unit are the mechanical elements (clutch, bearing blocks and shaft with rotors), the drive motor with variable speed via

frequency converter and tachogenerator, and the display and control unit with digital displays for power output and speed.

The motor base plate is mounted on a carriage, enabling the motor to be aligned. The large aluminium base plate with locating slots allows quick, flexible and precise assembly of the system components. A transparent protective cover provides the necessary safety during operation, and enables clear system viewing during experiments. All parts are clearly laid out and well protected in a storage system.

To measure and evaluate all experiments, the computerised vibration analyser PT 500.04 is required. The accessory sets PT 500.10 – PT 500.19 enable repeatable simulation of the different types of damage.

Use of the trolley PT 500.01 is recommended for flexible deployment of the training system.

Learning objectives/experiments

- introduction to vibration measuring methods on rotating machinery systems
 - ▶ fundamentals of measurement of shaft and bearing vibrations
 - ▶ basic variables and parameters
 - ▶ sensors and measuring devices
 - ▶ influences of speed and shaft layout
 - ▶ influence of sensor positioning
- field balancing of rigid shafts
- influence of alignment between motor and coupling
- understanding and interpreting frequency spectra
- use of a computerised vibration analyser

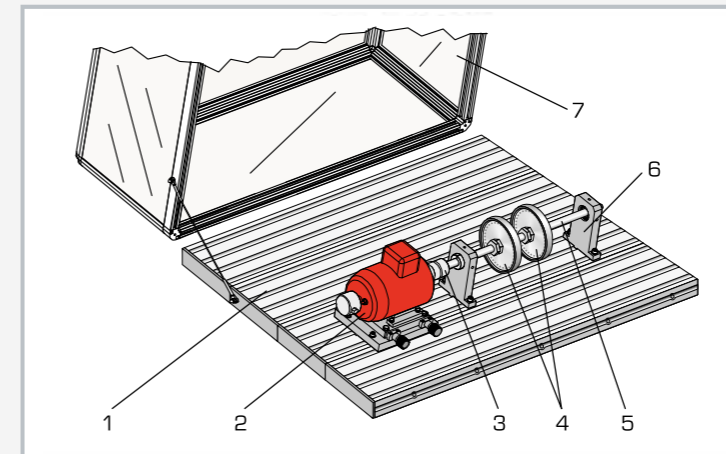

1 base plate, 2 drive motor with adjustable carriage, 3 coupling, 4 bearing unit, 5 shaft, 6 unbalanced flywheel, 7 transparent hood



The illustration shows the components in the storage system.



Screenshot of evaluation software: field balancing in two planes.

Specification

- [1] base unit for machinery diagnostic training system
- [2] rigid base plate with workpiece holder slots
- [3] drive motor with variable speed via frequency converter
- [4] digital speed and power display
- [5] 2 shafts: 1x short, 1x long
- [6] 2 unbalanced flywheels with interchangeable balance weights
- [7] bearing blocks, roller bearings, interchangeable
- [8] fixing holes for vibration measuring sensor
- [9] flexible claw coupling and Controlflex^R coupling
- [10] motor can be aligned obliquely and transversally
- [11] transparent protective hood
- [12] stackable system for components

Technical data

Base plate LxW: 1100x800mm

- M8-slots, spacing 50mm

Asynchronous motor with frequency converter

- drive power output: 0,37kW
- nominal speed: 2800min⁻¹
- speed range via frequency converter 100...6000min⁻¹
- display and control unit with digital power and speed display

2 shafts: Ø=20mm, length 300mm, 500mm

2 unbalanced flywheels: Ø=150mm, each 1675g, with interchangeable balance weights (bolts)
2 bearing blocks with roller bearings 6004 (can be exchanged)

Controlflex^R coupling: nominal torque: 15Nm

230V, 50Hz, 1 phase

230V, 60Hz, 1 phase; 120V, 60Hz, 1 phase

230V, 60Hz, 3 phases

LxWxH: 1100x800x500mm (base plate + hood)

LxWxH: 475x420x200mm (control unit)

LxWxH: 600x390x325mm (storage system)

Weight: approx. 95kg (total)

Scope of delivery

- 1 base plate with protective hood
- 1 display and control unit
- 1 asynchronous motor with frequency converter
- 2 shafts
- 2 unbalanced flywheels
- 2 clutches
- 2 bearing units
- 1 holder plate
- 2 clamp sets
- 1 set of tools
- 1 storage system with foam inlay
- 1 set of instructional material

PT 500 Classification

Experimentation kits and required/optional components

Experiments	Components							
	PT 500.05 Brake & Load Unit	PT 500.10 Elastic shaft kit	PT 500.12 Roller bearing faults kit	PT 500.14 Belt drive kit	PT 500.15 Damage to gears kit	PT 500.01 Laboratory trolley	PT 500.04 Computerised vibration analyser	PT 500 Machinery diagnostic system, base unit
PT 500.10 Elastic shaft kit								
PT 500.11 Crack detection in rotating shaft kit								
PT 500.12 Roller bearing faults kit								
PT 500.13 Couplings kit								
PT 500.14 Belt drive kit								
PT 500.15 Damage to gears kit								
PT 500.16 Crank mechanism kit								
PT 500.17 Cavitation in pumps kit								
PT 500.18 Vibrations in fans kit								
PT 500.19 Electromechanical vibrations kit								

- Component is optional
- Component is required
- PT 500.41 Two displacement sensors additionally required

PT 500.01 Laboratory trolley



The illustration shows PT 500.01 together with the base plate with protective hood from the base unit PT 500.

Description

- trolley for base unit
- four castors guarantee mobility

This laboratory trolley together with the PT 500 base unit permits the construction of a mobile experimental unit. The trolley features two shelves on which measuring units and other accessories can be placed. The sturdy trolley structure is manufactured from anodised aluminium section. The shelves are made from anodised aluminium sheet.

Specification

- [1] trolley for the modular machinery diagnostic training system PT 500
- [2] blocan section, aluminium
- [3] 4 castors, with brake

Technical data

Top area, LxW: 1100x770mm

LxWxH: 1100x770x820mm

Weight: approx. 39kg

Scope of delivery

- 1 trolley, complete

PT 500.04

Computerised vibration analyser

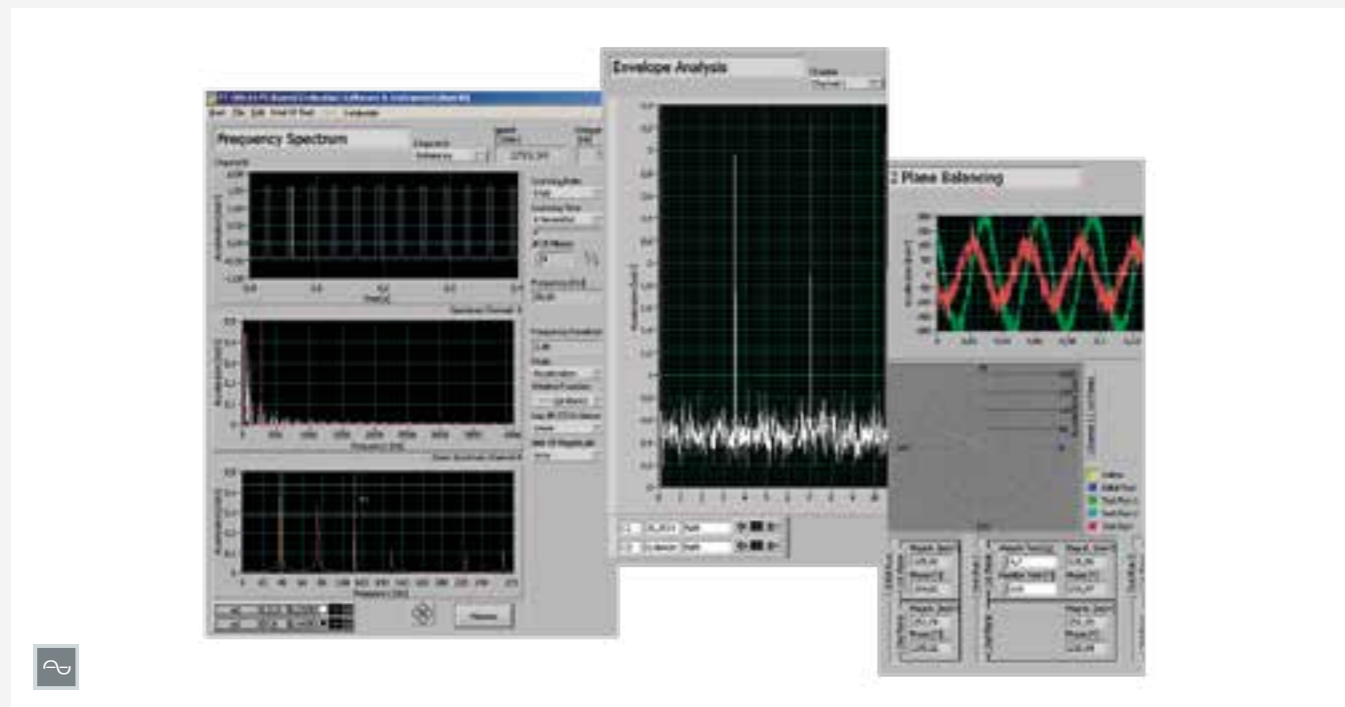

Description

- versatile, powerful software for vibration analysis
- supports all machinery diagnosis experiments of the PT 500 series
- suitable for field balancing of rotors in one and two planes

The computerised vibration analyser was developed specially to support analysis of machinery diagnosis experiments of the PT 500 series. The analyser can also be used in many other vibration experiments (such as TM 150).

The system comprises two acceleration sensors, a measuring amplifier with adjustable gain, a USB box and the analysis software.

The analysis software offers the following features: two-channel oscilloscope for investigations in the time range; two-channel spectrum analyser for investigations in the frequency range; vibration measuring unit; envelope analysis for bump effects and roller bearing damage; travelling filter to record run-up curves; orbit display; and a balancing module for field balancing of rigid rotors in one and two planes.

The software permits various analytical methods to be applied to a vibration signal and compared in terms of their efficacy. This enables the advantages and disadvantages of the various techniques to be effectively discovered. The balancing process is presented step-by-step.

The software features an intuitive user interface, and is highly user-friendly. An online help function provides guidance on the various functions. Measuring results can be printed out.

Cables, brackets and fixings are supplied.

Learning objectives/experiments

- within the context of the experiments in the complete PT 500 series, the following learning can be covered:
 - ▶ familiarisation with vibration signals
 - ▶ correct application of FFT analysis
 - ▶ measurement of speed, vibration displacement, vibration velocity and acceleration
 - ▶ assessment of the vibration state of a machine
 - ▶ damage analysis of roller bearings and gears by means of envelope spectra
 - ▶ detection of cracks in shafts by means of run-up curves and order analysis
 - ▶ measurement of imbalance vibrations and field balancing of rigid rotors in 1 and 2 planes

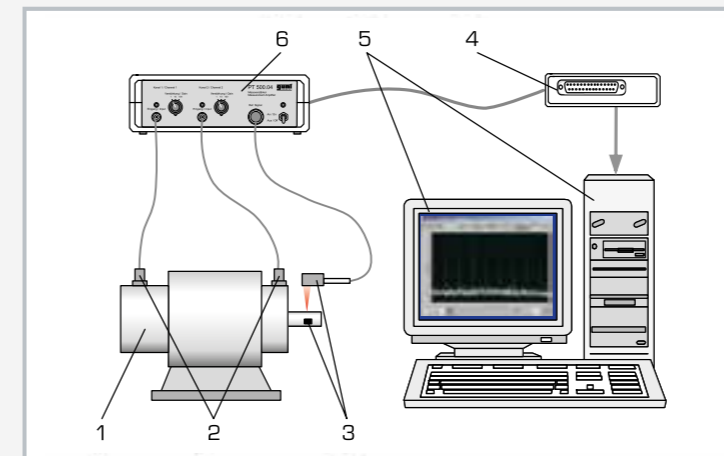

1 vibrating machinery, 2 acceleration sensors, 3 shaft with reference sensor, 4 USB box, 5 PC (PC not included), 6 measuring amplifier / filter



Application of the sensors: acceleration sensor on the black bearing support, speed sensor with holder



The illustration shows all components of PT 500.04

Specification

- [1] computerised vibration analyser for representation and evaluation of experiments with the PT 500 "Machinery diagnosis" series
- [2] 2 acceleration sensors to record vibration displacement, vibration velocity and acceleration
- [3] optical sensor to record speed
- [4] 2-channel measuring amplifier with adjustable gain
- [5] software features: 2-channel oscilloscope; 2-channel FFT analyser; envelope analysis; run-up curve and order analysis; 2-plane field balancing
- [6] 2 displacement sensors PT 500.41 can be connected
- [7] suitable for general vibration measuring tasks
- [8] stackable storage system to house the components
- [9] GUNT software for data acquisition via USB under Windows 7, 8.1, 10

Technical data

Acceleration sensors

- frequency range: 1...10000Hz
- sensitivity: 100mV/g
- resonance frequency: 32kHz

Optical speed sensor

- sampling width: 3...150mm
- laser class II, 675nm

Measuring amplifier

- adjustable gain: x1, x10, x100
- powered by 12VDC power supply unit
- LxWxH: 230x220x80mm

USB box

- 16x analogue in, 2x analogue out
- each 4x digital in/out

230V, 50Hz, 1 phase
230V, 60Hz, 1 phase; 120V, 60Hz, 1 phase
UL/CSA optional
LxWxH: 600x400x220mm (storage system)
Weight: approx. 6kg

Required for operation

PC with Windows

Scope of delivery

- 2 acceleration sensors
- 1 speed sensor with holder
- 1 amplifier
- 1 GUNT software CD + USB cable
- 1 USB box + data cable
- 1 combination wrench, AF 13
- 1 storage system with foam inlay
- 1 manual

PT 500.05

Brake & load unit



Description

- generation of a loading torque
- two speed and torque ranges
- vented magnetic particle brake with display and control unit

Many vibration phenomena can only be achieved when the system is under load. The brake and load unit is used to generate vibration as a function of torque, e.g. in toothed gearing mechanisms or electric motors.

It consists of a magnetic particle brake and an electric display and control unit. The braking torque can be finely adjusted on the display and control unit. The exciter current is applied as a measure of the braking torque and is indicated digitally on a display.

An integrated belt drive, with a free shaft, provides the brake with two torque and speed ranges. The energy is converted by the brake into heat and discharged to the ambient air by a fan.

The brake can be quickly and precisely mounted on the slotted plate of the PT 500 base unit.

PT 500.05 is used with the following kits:

- PT 500.13 Couplings
- PT 500.14 Belt drive
- PT 500.15 Damage to gears
- PT 500.19 Electromechanical vibrations

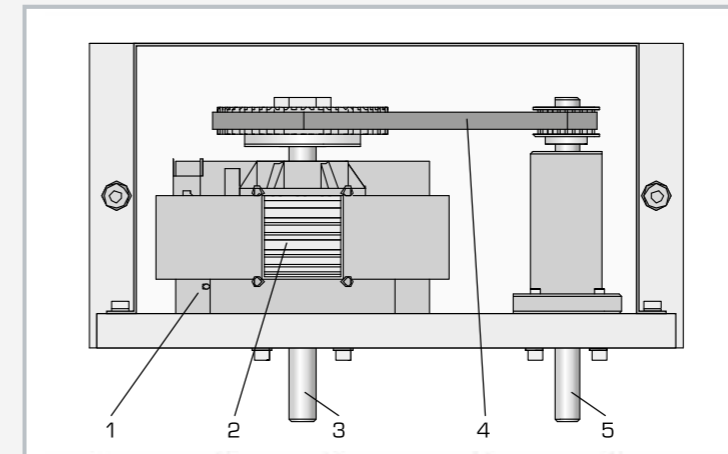

1 magnetic particle brake, 2 fan, 3 shaft for direct connection of brake, 4 belt drive, 5 shaft for connection of brake via belt drive

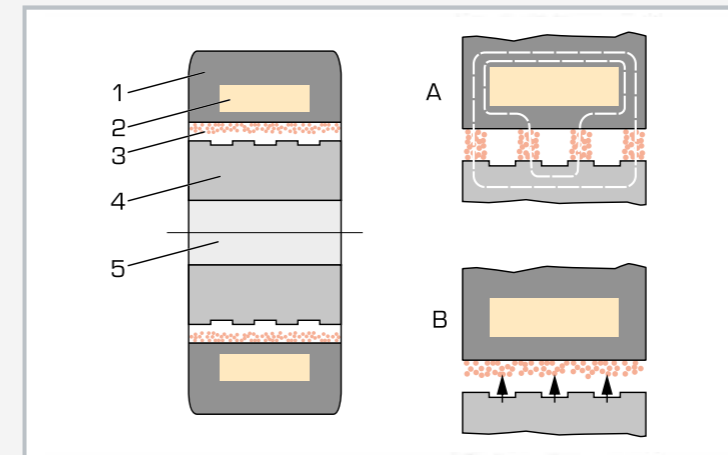

Principle of operation of a magnetic particle brake: 1 stator, 2 exciter coil, 3 gap with magnetic particles, 4 rotor, 5 shaft; A current flows: magnetic particles connect rotor and stator, resulting in friction and braking. B current flow interrupted: magnetic particles are pressed against the stator by centrifugal force, and the rotor can rotate



The illustration shows PT 500.05 together with PT 500, PT 500.01, PT 500.15 and PT 500.04.

Specification

- [1] brake and load unit for the machinery diagnostic training system
- [2] magnetic particle brake
- [3] display and control unit with exciter current display
- [4] potentiometer to adjust braking torque
- [5] integrated belt drive for second speed and torque range
- [6] temperature protection and fan overheating protection
- [7] stackable storage system to house the components

Technical data

Continuous braking power: approx. 450W/3000min⁻¹
Transmission ratio between brake shafts: i=3

Direct brake operation

- speed range: 200...2000min⁻¹
- braking torque: 1...10Nm

Operation via belt drive

- speed range: 600...6000min⁻¹
- braking torque: 0,3...3,3Nm

230V, 50Hz, 1 phase

230V, 60Hz, 1 phase; 120V, 60Hz, 1 phase

UL/CSA optional

LxWxH: 460x410x200mm (display and control unit)

LxWxH: 600x400x320mm (storage system)

Weight: approx. 30kg

Scope of delivery

- 1 magnetic particle brake
- 1 display and control unit
- 1 storage system with foam inlay
- 1 manual

PT 500.10

Elastic shaft kit

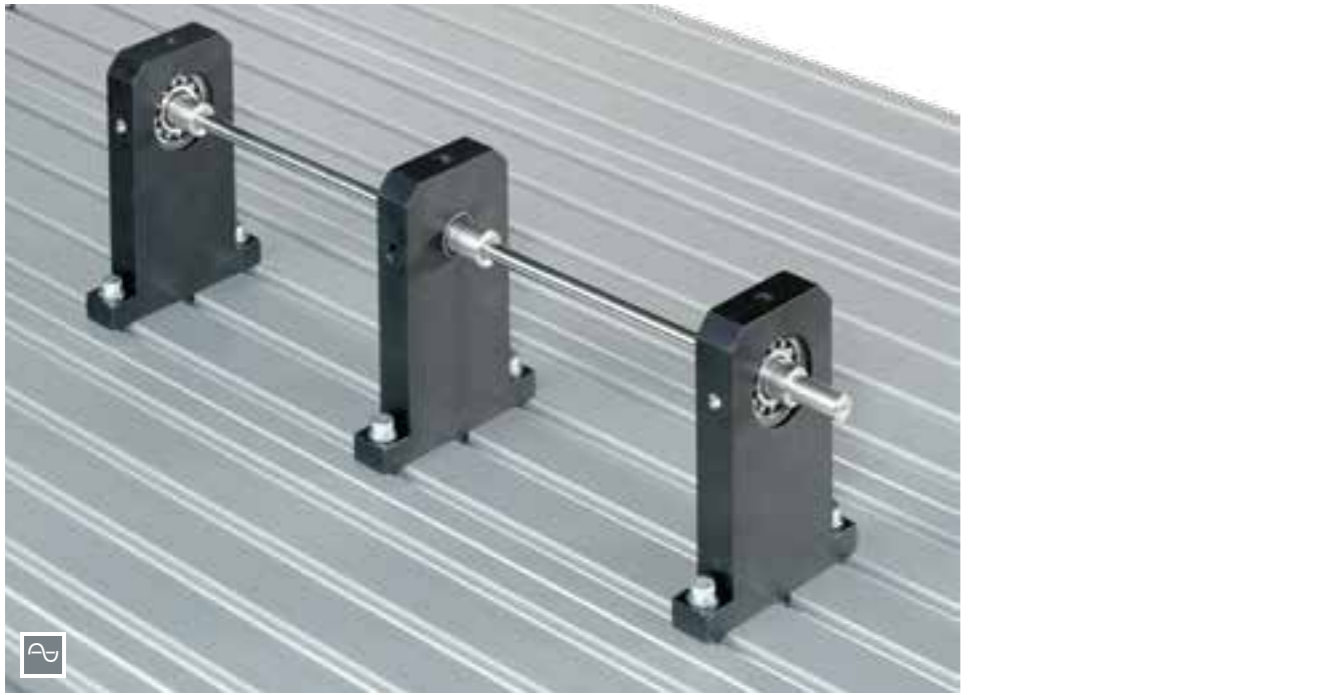

Description

- flexural vibration of the elastic shaft
- resonance and critical speed

This accessory setup enables the response of an elastic rotor to unbalanced excitation to be studied. The subcritical, supercritical and resonance running states can be demonstrated. A comparison of the orbits (path curves) in the subcritical and supercritical range is of particular interest.

The field balancing of elastic rotors is another area which can be investigated. The supplied pendulum ball bearings ensure full mobility of the shaft. The safety bearing limits the amplitudes to harmless values at speeds close to resonance.

The accessory setup is mounted on the base plate of the machinery diagnostic PT 500 base system.

To measure and evaluate the experiment, the computerised vibration analyser PT 500.04 and two displacement sensors PT 500.41 are required. It includes all the necessary sensors, a measuring amplifier and analysis software to record the vibration phenomena.

Learning objectives/experiments

- familiarisation with the terms "critical speed" and "resonance"
- influence of unbalanced excitation
- alignment of the elastic rotor
- influence of alignment errors
- understanding and interpreting frequency spectra
- use of a computerised vibration analyser
- together with two displacement sensors PT 500.41
 - ▶ study of the orbit in the subcritical and supercritical range

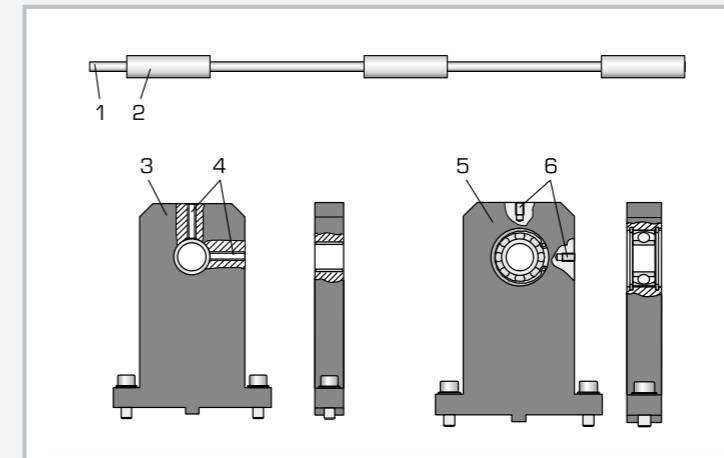

1 elastic shaft, 2 bearing, 3 safety bearing, 4 bores for displacement sensors, 5 bearing block with pendulum ball bearing, 6 bores for acceleration sensors



The illustration shows PT 500.10 together with PT 500, PT 500.01 and PT 500.04.

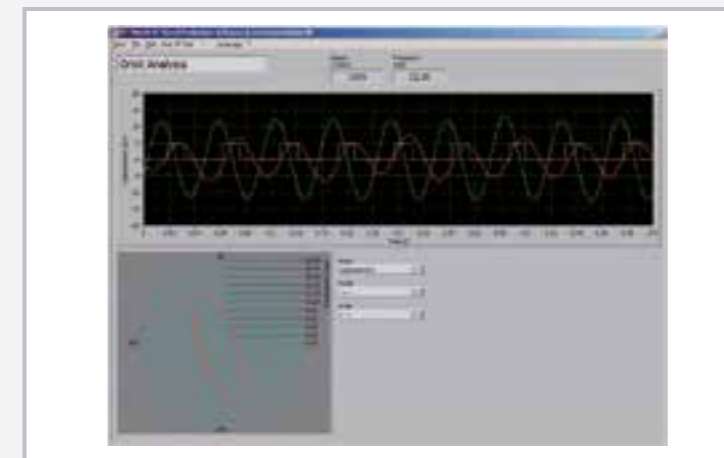

Screenshot of evaluation software
above: vibration signals as a function of time
below: orbit view for vibration on two planes

Specification

- [1] investigation of flexural vibration of an elastic shaft
- [2] stainless steel elastic shaft
- [3] 2 bearing blocks with pendulum ball bearing
- [4] 1 bearing
- [5] bearing blocks and safety bearing with bores for sensor mounting
- [6] accessory set for machinery diagnostic training system PT 500
- [7] stackable storage system to house the components

Technical data

Elastic shaft

- min. diameter: $\varnothing=10\text{mm}$
- diameter at bearings: $\varnothing=20\text{mm}$
- length: 530mm
- nominal length between bearings: 450mm

LxWxH: 600x400x120mm (storage system)
Weight: approx. 6kg

Scope of delivery

- 1 elastic shaft
- 2 bearing blocks
- 1 safety bearing
- 1 storage system with foam inlay
- 1 manual

PT 500.11**Crack detection in rotating shaft kit****Description**

- vibration behaviour of shaft with radial crack
- identification of damage

Cracks due to material fatigue are very dangerous for rotating machines. Early detection of any crack is therefore essential before permanent rupture and often fatal consequences can occur. The crack influences the vibration behaviour of the shaft by changing its rigidity. Using suitable analysis software, this change can be registered and inspection of the machine organised in good time.

In the experiment, the crack is simulated by an asymmetric flange joint. Variable tightening of the flange bolts produces a temporary gapping of the butt joint, which closely approximates to the behaviour of a crack.

The accessory setup includes two shafts of different lengths: one short and one long. The short shaft simulates a protruding shaft end, and is loaded with the PT 500.14 belt drive. The long shaft is used in conjunction with a safety bearing from PT 500.10 and an inertia disk from the base unit to investigate the effects of a crack in a shaft on the elastic rotor.

The accessory setup is mounted on the base plate of the machinery diagnostic base system PT 500.

To measure and evaluate the experiment, the computerised vibration analyser PT 500.04 is required. It includes all the necessary sensors, a measuring amplifier and analysis software to record the vibration phenomena.

Learning objectives/experiments

- change in characteristic vibration behaviour (natural frequency, resonance speed, amplitude and phase of vibrations) due to a crack
- crack identification from the change in vibration spectrum
- detection of cracks in rotating shafts at the protruding shaft end
- understanding and interpreting frequency spectra
- use of a computerised vibration analyser
- in conjunction with a safety bearing (e.g. from PT 500.10 – elastic shaft accessory setup)
 - ▶ detection of cracks in rotating shafts (the elastic rotor)

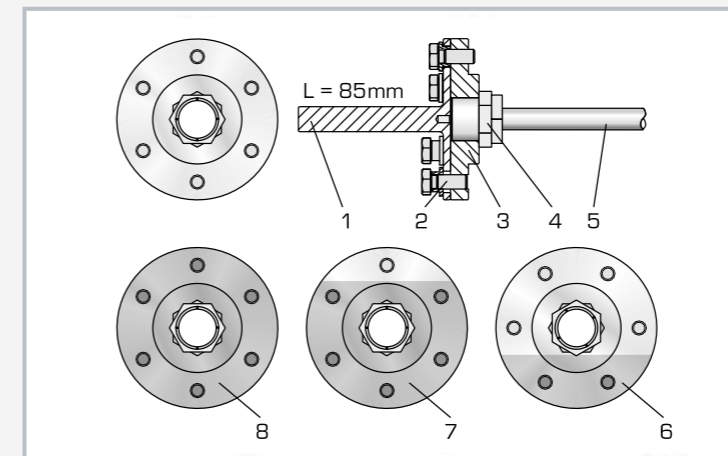

1 flange with short shaft (loaded by belt drive), 2 bolt, 3 pick-up disk, 4 clamp set, 5 driving shaft, 6 shaft with maximum crack (flange joint with 2 load-bearing bolts), 7 shaft with small crack (flange joint with 5 load-bearing bolts), 8 shaft with no crack (flange joint with 6 load-bearing bolts)



The illustration shows PT 500.11 together with PT 500, PT 500.01, PT 500.14 and PT 500.04.

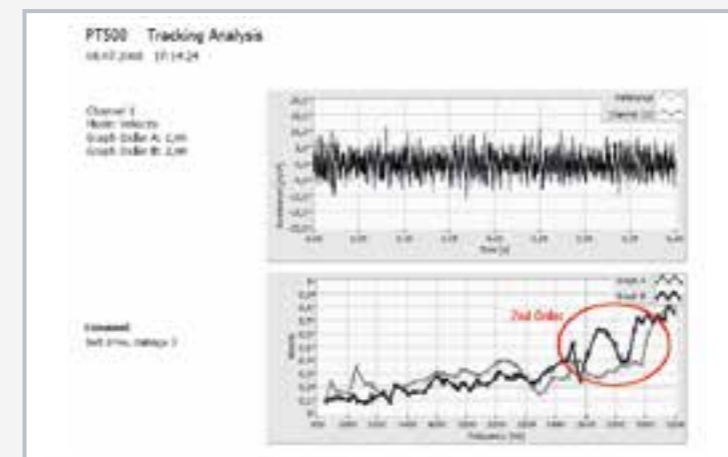

Tracking analysis of a rotor with crack: significant rise in amplitude in 2nd order (marked red)

Specification

- [1] investigation of the vibration behaviour of a cracked shaft
- [2] crack adapter in flange form
- [3] simulation of the crack by opening bolt joints
- [4] 4 different sized cracks can be simulated
- [5] short shaft to simulate a protruding shaft end
- [6] long shaft to simulate an elastic rotor
- [7] PT 500.14 (belt drive) generates required bending torque
- [8] accessory setup for PT 500 machinery diagnostic training system
- [9] stackable storage system to house the components

Technical data

Flange diameter: $\varnothing=90\text{mm}$
6 hexagon flange bolts M8x20

Shafts

- diameter: $\varnothing=20\text{mm}$
- short shaft: $L=85\text{mm}$
- long shaft: $L=200\text{mm}$
- max. permissible bending torques
 - ▶ short shaft for belt pulley: 15,9Nm
 - ▶ long shaft for mass disk: 3,9Nm

LxWxH: 400x300x120mm (storage system)
Weight: approx. 3kg

Scope of delivery

- 1 pick-up disk
- 1 long shaft
- 1 short shaft
- 1 centering arbor for alignment of shafts in experimental setup
- 6 bolts
- 1 clamp set
- 1 storage system with foam inlay
- 1 manual

PT 500.12

Roller bearing faults kit



Learning objectives/experiments

- vibrational spectrum of the running noise of roller bearings
- familiarisation with the envelope analysis
- influence of damage to outer race, inner race or roller body, on the spectrum
- estimating service lives of roller bearings
- influence of the lubricant on the vibration spectrum
- detection of faulty roller bearings
- understanding and interpreting frequency spectra
- use of a computerised vibration analyser

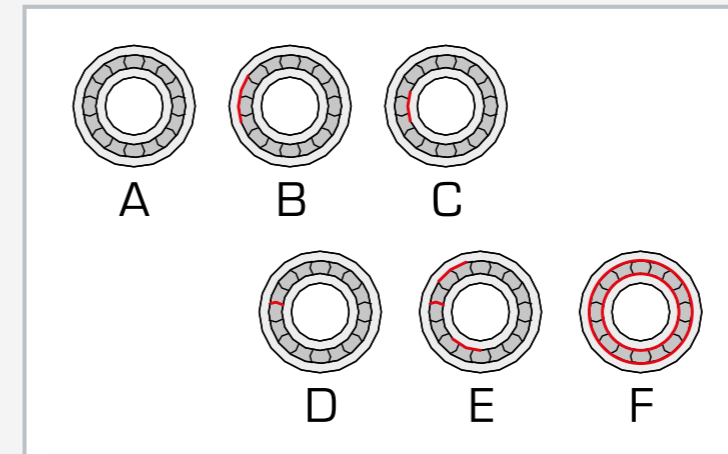

A) undamaged bearing, B) bearing with damage to outer race, C) bearing with damage to inner race, D) bearing with damage to a roller body, E) bearing with damage to roller body, outer and inner race, F) heavily worn bearing



The illustration shows PT 500.12 together with PT 500, PT 500.01, PT 500.14 and PT 500.04.

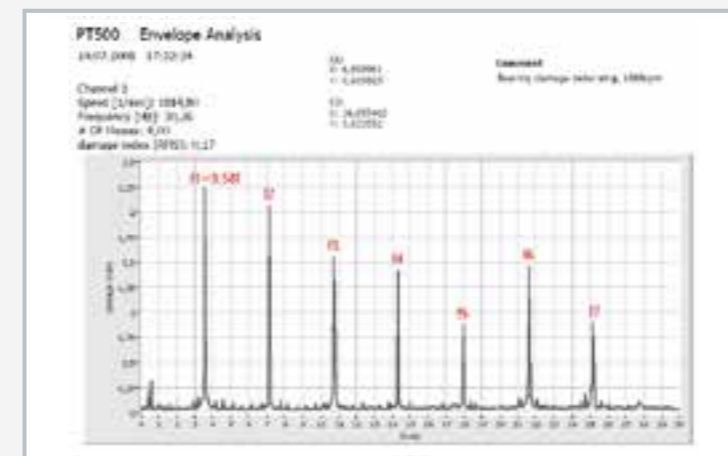

Envelope analysis of the bearing with damage on outer ring [B] at $f=1800\text{min}^{-1}$, damage frequency $f_1=3,58f$, harmonic waves f_2 to f_7

Specification

- [1] investigation of the vibrations of roller bearings
- [2] roller bearing with damage to outer race
- [3] roller bearing with damage to inner race
- [4] roller bearing with damage to a roller body
- [5] roller bearing with combined damage
- [6] long-running roller bearing
- [7] new and undamaged roller bearing
- [8] radial loading of bearings with PT 500.14 (belt drive)
- [9] accessory set for PT 500 machinery diagnostic training system
- [10] stackable storage system to house the components

Technical data

- Pendulum ball bearing of type NU204-E-TVP2
- inside diameter: $\varnothing=20\text{mm}$
 - outside diameter: $\varnothing=47\text{mm}$
 - width: 14mm
 - number of rollers: 12

LxWxH: 400x300x120mm (storage system)
Weight: approx. 4kg

Scope of delivery

- 6 roller bearings
- 1 bearing block
- 2 circlips
- 1 circlip pliers
- 1 storage system with foam inlay
- 1 manual

Description

- **assessment of bearing condition by vibration analysis**
- **comparison of bearings with different faults**

Vibration analysis is a key tool in estimating the condition of a roller bearing. The slow change in the vibration spectrum provides indications of the remaining life of a bearing and can be used as a criterion for its replacement. The spectral distribution can deliver accurate information on the type and location of the damage.

This accessory setup contains six roller bearings on which different faults can be detected and explained. The radial load on the bearing can be set within broad limits using the belt drive accessory set PT 500.14 (setting of belt tension; fixed load).

The accessory setup is mounted on the base plate of the machinery diagnosis base system PT 500.

To measure and evaluate the experiment, the computerised vibration analyser PT 500.04 is required. It includes all the necessary sensors, a measuring amplifier and analysis software to record the vibration phenomena.

PT 500.13 Couplings kit



The illustration shows PT 500.13 together with the claw coupling of PT 500.

Description

- vibration analysis of couplings
- radial run-out, axial run-out and pitch fault
- properties of different coupling types: pin coupling, curved teeth coupling, flange coupling, claw coupling

Rotating machine elements are interconnected by way of couplings. A coupling exhibiting production or assembly faults generates machine vibrations which can be analysed to give an indication of specific faults or damage.

The PT 500.13 accessory set can be used to simulate various faults and investigate their effects on vibration behaviour. The properties of various coupling types can also be compared. The curved teeth, pin, flange and claw coupling types are investigated. The couplings are installed between the motor and the shaft. The PT 500.05 load unit will also be required to investigate the behaviour of the couplings under load.

The accessory setup is mounted on the base plate of the machinery diagnostic base system PT 500.

To measure and evaluate the experiment, the computerised vibration analyser PT 500.04 is required. It includes all the necessary sensors, a measuring amplifier and analysis software to record the vibration phenomena.

Learning objectives/experiments

- effects of alignment errors on different coupling types
 - ▶ pin coupling with offset
 - ▶ claw coupling with offset
- effects of production faults such as radial run-out, axial run-out and pitch fault, on the running of the machine
 - ▶ flange coupling with no fault
 - ▶ flange coupling with radial run-out
 - ▶ flange coupling with axial run-out
 - ▶ pin coupling with no fault
 - ▶ pin coupling with pitch fault
- identification of coupling faults from the vibration signal
- load dependency of running behaviour
- influence of gear rim hardness on claw couplings
- comparison of curved teeth, pin, flange and claw couplings
- understanding and interpreting frequency spectra
- use of a computerised vibration analyser

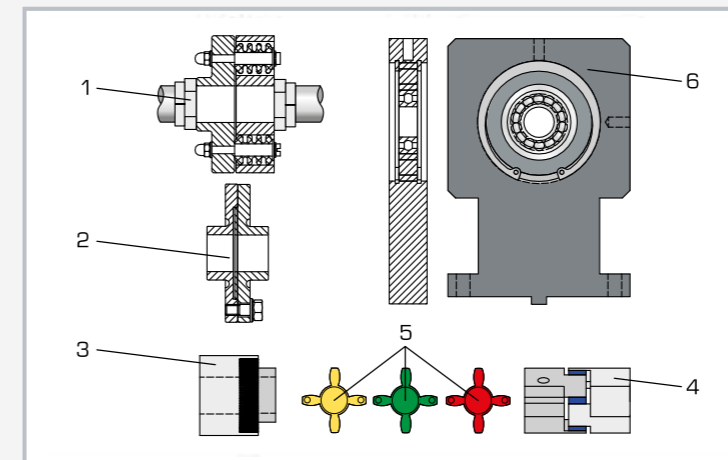

1 pin coupling, 2 flange coupling, 3 curved teeth coupling, 4 claw coupling with coupling star (both from PT 500), 5 coupling stars, 6 bearing block with elastic bearing

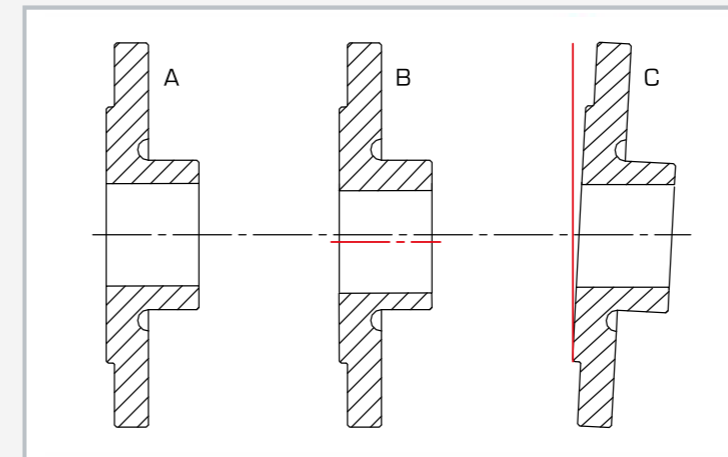

Flange coupling halves: A without fault, B eccentricity, C wobble



The illustration shows PT 500.13 together with PT 500, PT 500.01, PT 500.05 and PT 500.04.

Specification

- [1] investigation of the vibration behaviour of various coupling types with and without faults
- [2] curved teeth coupling
- [3] 3 different coupling stars for the elastic claw coupling of the base unit PT 500
- [4] flange coupling with no fault
- [5] flange coupling with radial run-out
- [6] flange coupling with axial run-out
- [7] pin coupling with and without pitch fault
- [8] experimental setup can be used with brake and load unit PT 500.05
- [9] accessory set for PT 500 machinery diagnosis training system
- [10] stackable storage system to house the components

Technical data

Pin coupling

- 1x centric pin
- 1x eccentric pin
 - ▶ eccentricity of pin: 1mm
- max. pitch fault: $180^\circ \pm 1,909^\circ$

Coupling stars for claw coupling

- 98 Shore A (red)
- 92 Shore A (yellow)
- 64 Shore D (green)
- 80 Shore A (blue, included in PT 500)

Flange coupling

- radial run-out (centre offset): 0,2mm
- axial run-out: $0,4 \pm 0,1$ mm

LxWxH: 400x300x170mm (storage system)

Weight: approx. 6kg

Scope of delivery

- 1 curved teeth coupling
- 1 flange coupling with no fault
- 1 flange coupling with radial run-out
- 1 flange coupling with axial run-out
- 1 pin coupling with adjustable pitch fault
- 3 coupling stars
- 1 bearing block
- 1 set of tools
- 1 storage system with foam inlay
- 1 manual

PT 500.14 Belt drive kit



Description

- vibrations in belt drives
- resonance and critical speed

When properly designed, manufactured, and correctly set; belt drives are low-maintenance, low-noise, long-life drive units. It is important that the belt should not vibrate and/or slip.

The PT 500.14 accessory setup can be used to investigate conditions that cause vibration or slip. The effect of disparate elongation on multiple belt drives can be demonstrated by means of individually-adjustable tensioning rollers. The belt drive is a dual belt drive with a belt tensioner. It can, however, also be operated with only one belt. An eccentrically-bored small belt pulley and a damaged V-belt enhance the range of possible experiments.

The brake and PT 500.05 load unit is required to conduct the experiment. The accessory set PT 500.14 can also be used to apply transverse loads in other experiments.

The accessory set is mounted on the base plate of the machinery diagnostic base system PT 500.

To measure and evaluate the experiment, the computerised vibration analyser PT 500.04 is required. It includes all the necessary sensors, a measuring amplifier and analysis software to record the vibration phenomena.

Learning objectives/experiments

- influence of belt tension on vibration behaviour
- influence of speed on vibration behaviour
- influence of pulleys running untrue, and off-track running
- power split across multiple belt drive
- influence of slip on vibration running spectrum
- comparison between fault-free and damaged belts
- understanding and interpreting frequency spectra
- use of a computerised vibration analyser

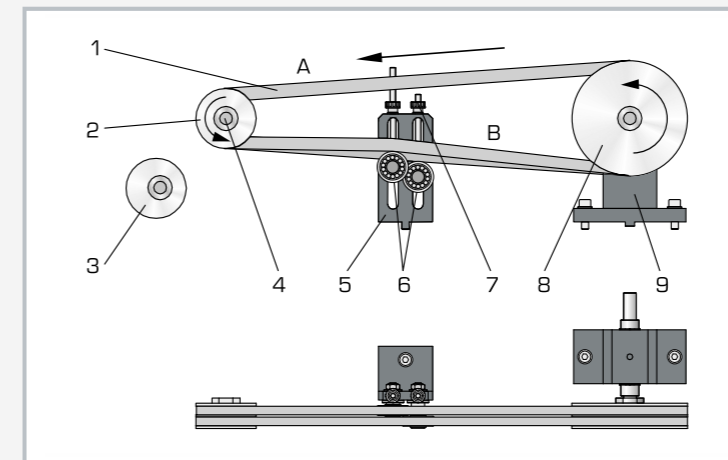

1 belt, 2 small belt pulley (driving), 3 small eccentric V-belt pulley, 4 clamp set, 5 belt tensioner, 6 tensioning rollers, 7 adjustment of V-belt tension, 8 large V-belt pulley, 9 bearing block

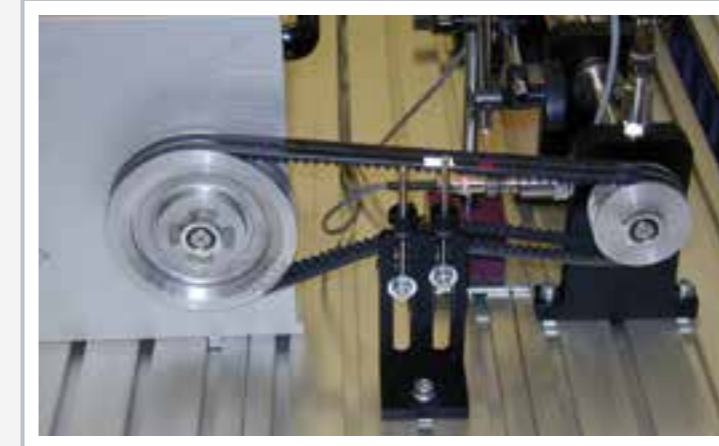

The illustration shows PT 500.14 together with PT 500.05.

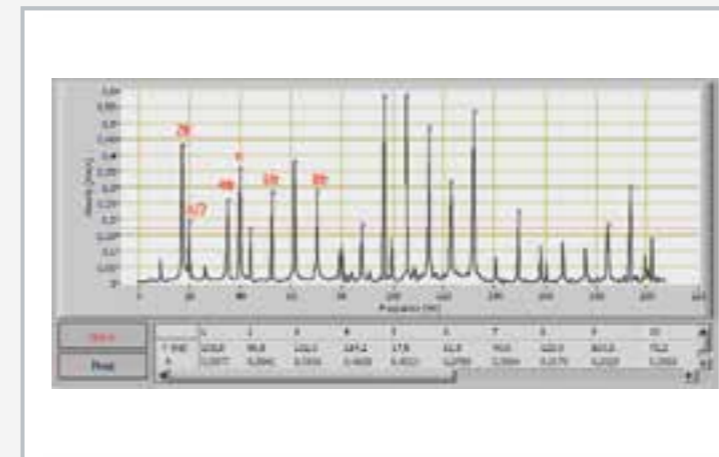

Frequency spectrum on the belt drive
belt frequency f , with harmonic waves $2f$, $4f$, $6f$, drive speed n , $n/2$

Specification

- [1] investigation of the vibrations of belt drives
- [2] dual belt drive with V-belt
- [3] belt drive can be operated with one belt
- [4] individually-adjustable tensioning rollers
- [5] belt drive with radial run-out
- [6] damaged V-belt
- [7] belt pre-tension measuring unit 0...150N
- [8] suitable for applying transverse loads on other systems within the accessory sets of the PT 500 series
- [9] brake and load unit PT 500.05 required for experiments on the belt drive
- [10] accessory set for PT 500 machinery diagnostic training system
- [11] stackable storage system to house the components

Technical data

V-belt pulleys

- large: $\varnothing=125\text{mm}$
- small: $\varnothing=63\text{mm}$
- small, eccentric: $\varnothing=63\text{mm}$

Axle centres: 300mm

V-belt

- SPZ, approx. 10mm wide
- belt length: 912mm

LxWxH: 600x400x170mm (storage system)

Weight: approx. 6kg

Scope of delivery

- 3 V-belts
- 3 belt pulleys
- 1 tensioning roller set
- 1 belt pre-tension measuring unit
- 1 storage system with foam inlay
- 1 manual

PT 500.15

Damage to gears kit



Description

- vibration analysis of tooth damage
- fault localisation on gears

The PT 500.15 accessory setup is used to simulate typical damage to gears and study its effects on vibration behaviour. Various gear sets with tooth damage are supplied for this purpose. Undamaged gear sets are provided for comparative purposes. The difference between spur toothed and helical gearing can also be demonstrated. The influence of the centre distance and backlash can be studied using adjustable bearing plates. The type of lubrication has a significant influence on the vibration signal, so grease or gear oil can be used for lubrication.

The housing, with holes to accommodate sensors, is used for vibration experiments. The transparent housing cover allows the gear to be observed in operation without taking vibration measurements.

The PT 500.05 brake and load unit will be required to subject the gear unit to load.

The accessory setup is mounted on the base plate of the machinery diagnostic base system PT 500.

To measure and evaluate the experiment, the computerised vibration analyser PT 500.04 is required. It includes all the necessary sensors, a measuring amplifier and analysis software to record the vibration phenomena.

Learning objectives/experiments

- identification of gear damage from vibration behaviour
- influence of gearing type
 - ▶ spur toothed
 - ▶ helical
- localisation of damage
- influence of lubrication
- influence of centre distance and of backlash
- understanding and interpreting frequency spectra
- use of a computerised vibration analyser

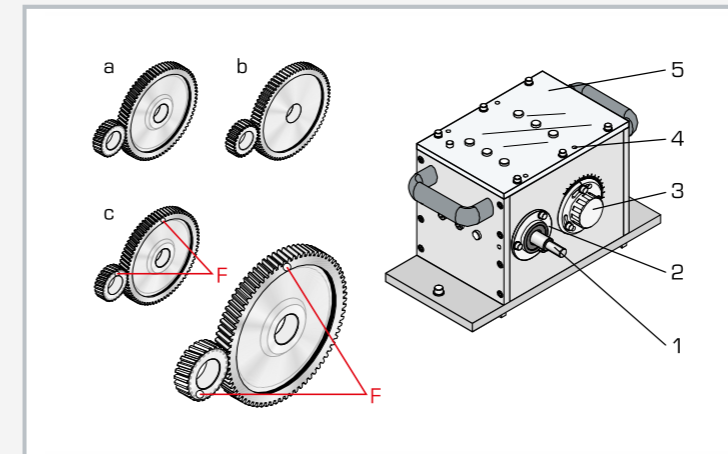

1 shaft end, 2 bearing cover with shaft gland, 3 bearing cover with centre distance adjustment facility, 4 tapped hole for vibration sensor, 5 transparent gear unit cover; a helical gear set, b spur toothed gear set, c damaged gear sets; F fault



The illustration shows PT 500.15 together with PT 500, PT 500.01, PT 500.05 and PT 500.04.

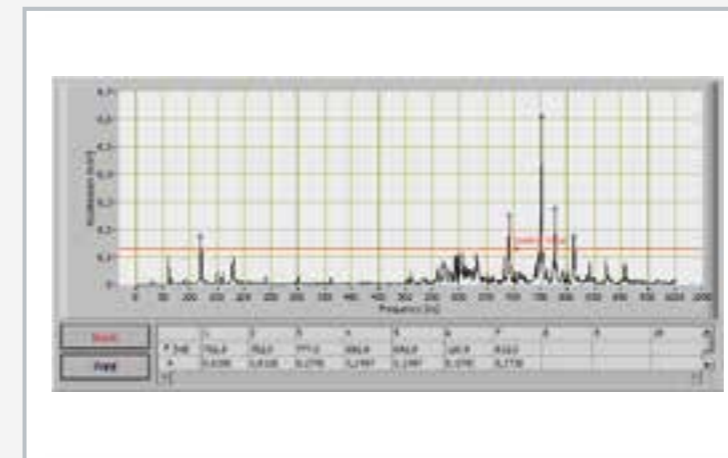

Spectrum of a spur toothed gear at 1800min⁻¹: tooth gearing frequency 752Hz

Specification

- [1] investigation of the vibration behaviour of gears
- [2] two-shaft gear unit
- [3] 2 damaged and 2 undamaged gear sets
- [4] spur toothed and helical gearing
- [5] housing with sensor holes
- [6] transparent housing cover
- [7] gear can be lubricated with grease or oil
- [8] loading of experimental setup with brake and load unit PT 500.05
- [9] accessory set for PT 500 machinery diagnostic training system
- [10] stackable storage system to house the components

Technical data

Transmission ratio i: 1:3
Centre distance adjustable
Reference profile to DIN 867

Spur toothed gear sets

- gear wheel: 75 teeth on each, m=2mm
- pinion: 25 teeth on each, m=2mm

Helical gear sets

- gear wheel: 75 teeth on each, m=2mm
- pinion: 25 teeth on each, m=2mm
- helix angle: 10°

LxWxH: 600x400x320mm (storage system)
Weight: approx. 25kg

Scope of delivery

- 1 gearbox
- 1 transparent housing cover
- 1 housing cover with sensor holes
- 4 gear wheels
- 4 pinions
- 1 motor oil SAE 10W 40, 1,5L
- 1 storage system with foam inlay
- 1 manual

PT 500.16 Crank mechanism kit



Description

- vibrations of crank drives
- bearing clearance or slack in oscillating machine components

Crank drives are frequently used in compressors and pumps. They cause vibration due to the oscillating masses and forces. Under the alternating stress in the drive mechanism, bearing clearance, for example, can generate shock impacts with high-frequency exciter spectra. In addition, free mass forces generate harmonic vibrations due to their non-linear kinematics.

The PT 500.16 accessory set enables the stroke, mass balance and bearing clearance on the crosshead to be adjusted. The speed is adjusted using the base unit PT 500. Gas forces such as occur in compressors or combustion engines can be simulated using springs. Experiments with gas forces require higher torques which are attained by reducing the speed of the drive motor from the base unit PT 500. This reduction is achieved either with the PT 500.14 belt drive or the PT 500.15 gear unit.

The transmission of alternating torque in toothed gearing mechanisms can be investigated together with accessory set PT 500.15 (for investigating damage to gears).

The accessory set is mounted on the base plate of the machinery diagnostic base system PT 500.

To measure and evaluate the experiment, the computerised vibration analyser PT 500.04 is required. It includes all the necessary sensors, a measuring amplifier and analysis software to record the vibration phenomena.

Learning objectives/experiments

- experimental modal analysis of mechanical systems
- familiarisation with the envelope analysis
- influence of bearing clearance and shock impact
- inconsistent torque characteristic
- wear measurement on piston rods
- understanding and interpreting frequency spectra
- use of a computerised vibration analyser
- in conjunction with PT 500.15
 - ▶ transmission of alternating torque in toothed gearing mechanisms
- in conjunction with PT 500.14 or PT500.15
 - ▶ influence of gas forces on the vibration spectrum

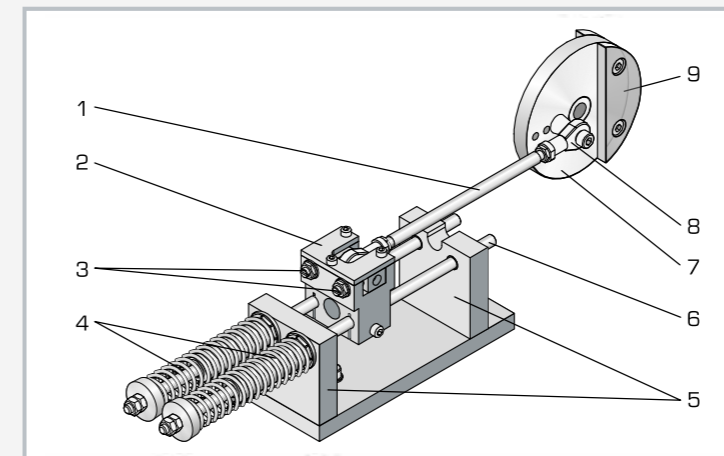

1 connecting rod, 2 crosshead, 3 adjustment of bearing clearance, 4 pressure spring, 5 bearing block with journal bearing, 6 piston rod, 7 crank disk, 8 articulated head, 9 balance mass



The illustration shows PT 500.16 together with PT 500, PT 500.01 and PT 500.04.

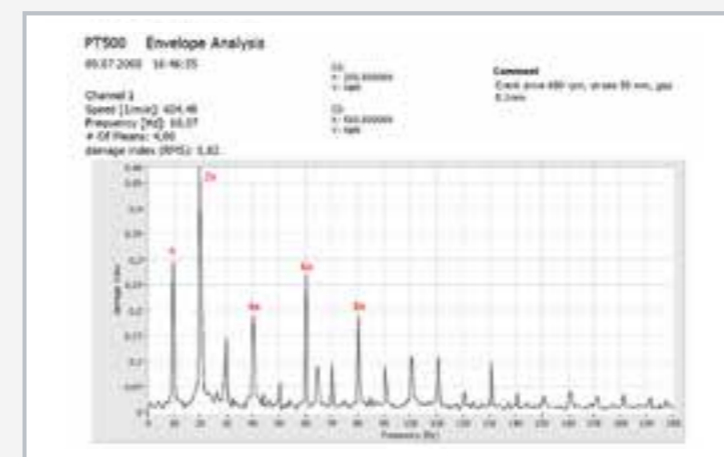

Envelope analysis on crank drive with clearance at 600min⁻¹. Dominant is the 2nd order 2n with harmonic waves 4n, 6n, 8n etc.

Specification

- [1] investigation of the vibrations of crank drives
- [2] crank drive with adjustable stroke
- [3] interchangeable bearing bushes permit simulation of bearing clearance
- [4] springs simulate gas forces
- [5] can be used together with gear damage accessory set PT 500.15
- [6] belt drive PT 500.14 or gear unit PT 500.15 required for experiment with gas forces
- [7] accessory set for PT 500 machinery diagnostic training system
- [8] stackable storage system to house the components

Technical data

Stroke: 50 - 75 - 100mm

Balance mass total

- 490g, rated for operation with 50mm stroke

Bearing clearance: 0...1mm

Pressure spring

- relaxed length: 170mm
- spring stiffness: $R=0,55N/mm$

LxWxH: 600x400x170mm (storage system)

Weight: approx. 8kg

Scope of delivery

- 1 crank drive
- 2 springs
- 2 balance masses
- 1 set of tools
- 1 storage system with foam inlay
- 1 manual

PT 500.17 Cavitation in pumps kit



Description

- observation and measurement of cavitation
- understanding conditions for cavitation

Cavitation can play a major role in the vibration of pumps during operation.

With the PT 500.17 accessory set, cavitation can be experimentally induced and its influence on the vibration spectrum investigated.

The principal elements of the accessory set are a single-stage centrifugal pump and a storage tank. The pump and tank are interconnected by hoses. Valves and manometers in the delivery and intake lines allow various operating conditions to be set. The transparent plastic pump housing provides a view into the interior of the pump during operation. This enables the formation of cavitation bubbles to be observed. Stroboscopic analysis is specially recommended (stroboscope not supplied).

The pump can be driven directly through a flexible coupling on the base system PT 500 or by the PT 500.14 belt drive.

The accessory set is mounted on the base plate of the machinery diagnostic base system PT 500.

To measure and evaluate the experiment, the computerised vibration analyser PT 500.04 is required. It includes all the necessary sensors, a measuring amplifier and analysis software to record the vibration phenomena.

Learning objectives/experiments

- observing and understanding cavitation in a centrifugal pump
 - ▶ visually
 - ▶ stroboscopically (stroboscope available as accessory)
 - ▶ by vibration analysis
- investigation of the operational vibrations of a centrifugal pump
- understanding and interpreting frequency spectra
- use of a computerised vibration analyser

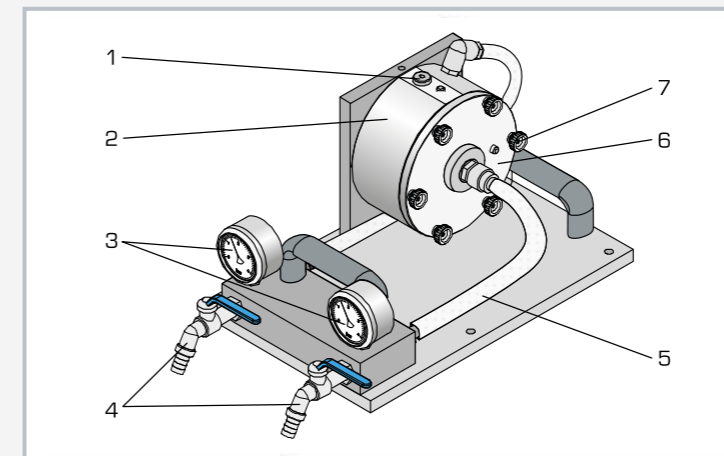

1 pump housing vent screw, 2 pump housing, 3 manometer, 4 valve, 5 intake side hose, 6 housing cover, 7 thumb screw to open the housing cover



The illustration shows PT 500.17 together with PT 500 and PT 500.01.

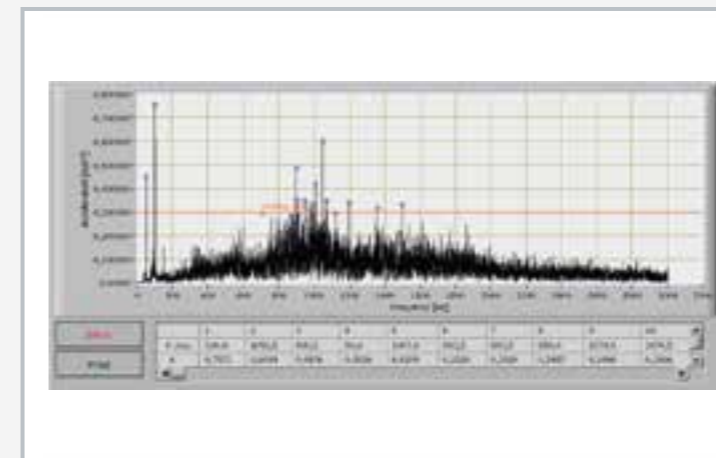

Software screenshot: frequency spectrum in cavitation

Specification

- [1] investigation of the conditions for cavitation in pumps
- [2] single-stage centrifugal pump
- [3] valves and manometers in delivery and intake lines allow to set operating conditions including generating cavitation
- [4] transparent housing
- [5] pump driven via coupling (PT 500) or with belt drive PT 500.14
- [6] accessory set for PT 500 machinery diagnostic training system
- [7] stackable storage system to house the components

Technical data

Centrifugal pump

- max. flow rate at 3300min⁻¹: 17L/min
- max. head at 3300min⁻¹: 12m
- impeller with 3 blades
- min. speed for cavitation: approx. 2240min⁻¹ (with restriction on intake side)

Tank

- material: HDPE
- capacity: 20L

Manometer

- delivery side: 0...4bar
- intake side: -1...1,5bar

LxWxH: 600x400x320mm (storage system)

Weight: approx. 16kg

Scope of delivery

- 1 pump
- 1 tank
- 1 set of hoses
- 1 storage system with rubber mat
- 1 manual

PT 500.18

Vibrations in fans kit



Description

- vibration measurements on fans
- simulation of blade-induced vibrations

Vibration measurements on fans and blowers play a major role in field monitoring operations. In addition to the usual signals caused by bearings and imbalance, the vibrations induced by the fan blades can be measured. The vibrations are induced by inhomogeneous flow fields.

The PT 500.18 accessory set induces the vibrations magnetically. Three fan rotors with differing numbers of blades can be investigated. A guard plate covers the rotating fans. An obliquely-mounted inertia disk is used to investigate the gyroscopic effect. Just as in actual practice, the fan model can also be driven directly via a flexible coupling or by the belt drive PT 500.14.

The accessory set is mounted on the base plate of the machinery diagnostic base system PT 500.

To measure and evaluate the experiment, the computerised vibration analyser PT 500.04 is required. It includes all the necessary sensors, a measuring amplifier and analysis software to record the vibration phenomena.

Learning objectives/experiments

- vibration measurement on fans
- measurement of blade pass frequency
- identification of the vibration induced by the blades from the vibration spectrum
- effect of dynamic imbalance on the fan
- understanding and interpreting frequency spectra
- use of a computerised vibration analyser

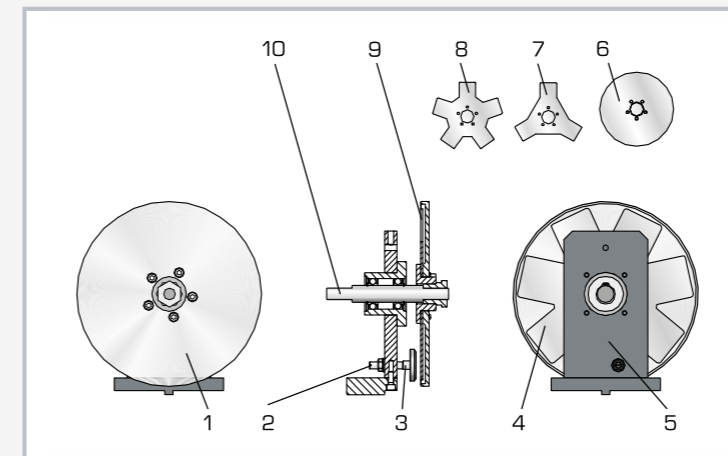

1 guard disk, 2 adjuster screw for gap between magnet and blades, 3 permanent magnet, 4 fan rotor with 7 blades, 5 bearing block, 6 mass disk to simulate axial forces, 7 fan rotor with 3 blades, 8 fan rotor with 5 blades, 9 fan blade, 10 fan shaft



The illustration shows PT 500.18 together with PT 500 and PT 500.01.

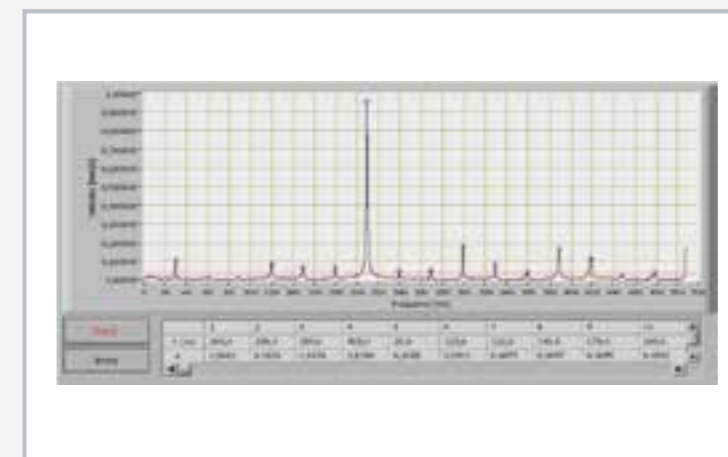

Frequency spectrum of a fan rotor with 7 blades: clear blade passing frequency at 210Hz

Specification

- [1] investigation of the vibrations of fans
- [2] model of an axial fan with blades
- [3] magnetic induction of blade forces
- [4] obliquely-mounted inertia disk to investigate gyroscopic effects
- [5] 3 fan rotors with different numbers of blades
- [6] guard disk for fan rotors
- [7] gap between magnet and blades adjustable
- [8] can be used with belt drive PT 500.14
- [9] accessory set for PT 500 machinery diagnosis training system
- [10] stackable storage system to house the components

Technical data

Sheet-steel fan rotor

- 3 blades
- 5 blades
- 7 blades
- Ø 204mm
- max. speed: 3000min⁻¹

Protective disk, made of aluminium

- Ø 220mm

LxWxH: 400x300x320mm (storage system)

Weight: approx. 6kg

Scope of delivery

- 3 fan rotors
- 1 mass disk
- 1 holder
- 1 guard disk
- 1 storage system with foam inlay
- 1 manual

PT 500.19

Electromechanical vibrations kit



Learning objectives/experiments

- influence of the gap on vibration behaviour
- influence of electromagnetic asymmetry on vibration behaviour
- influence of the load on the level of vibration
- influence of the gap on electromagnetic losses and efficiency
- influence of speed on vibration behaviour
- understanding and interpreting frequency spectra
- use of a computerised vibration analyser
- in conjunction with a current measuring probe
 - ▶ measurement of current consumption per phase

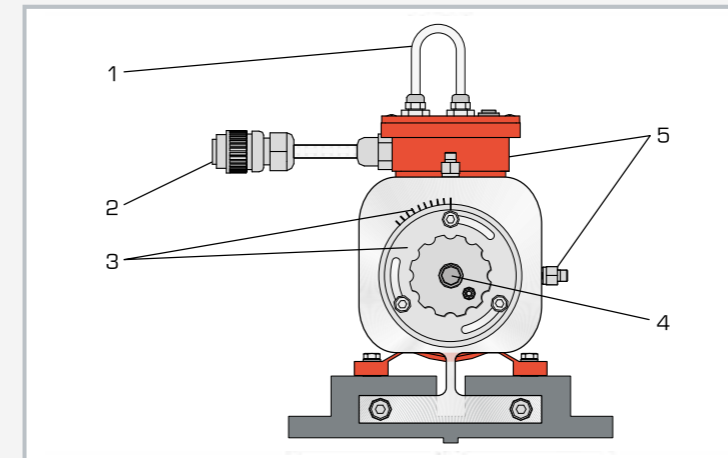

1 current measuring probe tap for the 3 phases, 2 connection to the display and control unit of PT 500, 3 bearing cover with adjustable centering and scale, to adjust gap, 4 motor shaft, 5 adapter for acceleration sensors

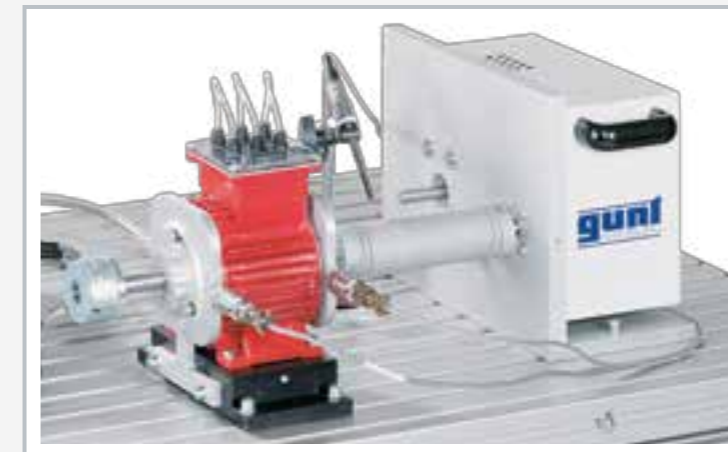

The illustration shows PT 500.19 together with PT 500, PT 500.01 and PT 500.05.

Specification

- [1] investigation of vibration behaviour of an electric motor
- [2] asynchronous motor with adjustable gap
- [3] asymmetric magnetic field by winding with shut-off facility
- [4] variable speed via frequency converter of base unit
- [5] speed display on display and control unit of base unit PT 500
- [6] power display on display and control unit of base unit PT 500
- [7] accessory set for PT 500 machinery diagnostic training system
- [8] stackable storage system to house the components

Technical data

Asynchronous motor with variable speed
 ■ speed range: 100...6000min⁻¹
 ■ nominal power output: 370W

Eccentricity of armature: 0...0,2mm

LxWxH: 400x300x320mm (storage system)
 Weight: approx. 11kg

Scope of delivery

- 1 electric motor with terminal box
- 1 storage system with foam inlay
- 1 manual

Description

- interaction of electromagnetic and mechanical elements of the system
- adjustable asymmetric gap between stator and rotor
- electromagnetic asymmetry with winding that can be switched off

Asynchronous motors are in widespread use as drive mechanisms. These motors can generate machine vibrations. If there is an asymmetric gap, the circulating magnetic forces induce rotational and bending vibrations. The same applies to partial failure of the electrical windings. In this case, the asymmetrical magnetic field also induces mechanical vibrations.

The PT 500.19 accessory set features an adjustable centering device to adjust an asymmetrical gap. A winding that can be switched off generates an electromagnetic asymmetry. The display and control unit of the PT 500 base system powers the asynchronous motor and permits the speed to be adjusted. The motor is subjected to load by the PT 500.05 brake and load unit.

The accessory set is mounted on the base plate of the machinery diagnostic base system PT 500.

To measure and evaluate the experiment, the computerised vibration analyser PT 500.04 is required. It includes all the necessary sensors, a measuring amplifier and analysis software to record the vibration phenomena.

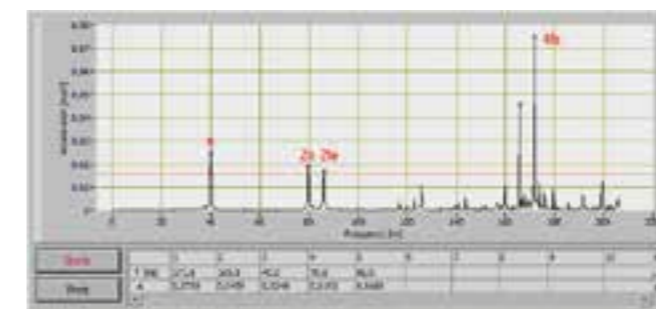

Typical spectrum of an electric motor
 rotary frequent vibration with n , $2n$ because of balance error
 power frequent vibration with $2fe$, $4fe$ because of magnetic forces

Engineering design

Introduction

Overview Engineering design	254
---------------------------------------	-----

Engineering drawing

Overview Engineering drawing and cutaway models	256
TZ 100 Engineering drawing: three-dimensional display	258
TZ 200.61 Engineering drawing: rotationally symmetrical components	260
TZ 200.02 Engineering drawing: casting	262
TZ 200.08 Engineering drawing: safety catch	263
TZ 300 Assembly of lever press	264
TZ 200.11 Assembly of bending device	266
TZ 200.71 Assembly of lever shears	268

Cutaway models

GL 300.01 Cutaway model: worm gear	270
GL 300.02 Cutaway model: mitre gear	271
GL 300.03 Cutaway model: spur gear	271
GL 300.04 Cutaway model: two-stage spur gear	271
GL 300.05 Cutaway model: planetary gear	271
GL 300.06 Cutaway model: variable speed belt drive	271
GL 300.07 Cutaway model: control gear	271
GL 300.08 Cutaway model: multiple-disk clutch	271
GL 300.12 Cutaway model: pedestal bearing	271

Machine elements: connecting elements

Overview Machine elements	272
MG 901 Nuts and bolts kit	274
MG 903 Screw-locking devices kit	275
MG 905 Thread types kit	276
TM 320 Screw connections testing	277
TM 310 Thread testing	278

Machine elements: bearing elements

MG 911 Roller bearings kit	279
--------------------------------------	-----

Machine elements: transmission elements

GL 100 Principle of gear units	280
GL 110 Cam mechanism	281
TM 123 Spur gear unit	282
TM 124 Worm gear unit	283
TM 125 Cable winch	284
TM 220 Belt drive and belt friction	286
GL 410 Assembly simple gears	288
GL 420 Assembly combined gears	290
GL 430 Assembly control gear	292
GL 200 Lathe gear	294
AT 200 Determination of gear efficiency	296

Assembly exercises

Overview Assembly exercises	298
MT 170 Assembly shaft with journal bearings	300
MT 171 Assembly hydrodynamic journal bearing	302
MT 152 Assembly spur gear	304
MT 110.02 Assembly spur wheel / worm gear mechanism	306
MT 172 Alignment of drives, shafts and gears	308
MT 190 Assembly materials tester	310
MT 190.01 Assembly data acquisition for materials tester	312

Engineering design

Engineering design means describing technical products in full, thereby enabling their manufacture. This includes observations and concepts with sketches, calculations and initial drafts, all the way up to lists of parts and drawings with specifications for materials, machining, dimensions and tolerances. The applied principles of engineering design are taught in the engineering design discipline. Engineering design is a central and challenging area of learning within engineering education.

By carefully developing fundamental topics such as statics, strength of materials and dynamics, machine elements, materials testing, descriptive geometry and engineering drawings, students are prepared for subsequent professional activities.

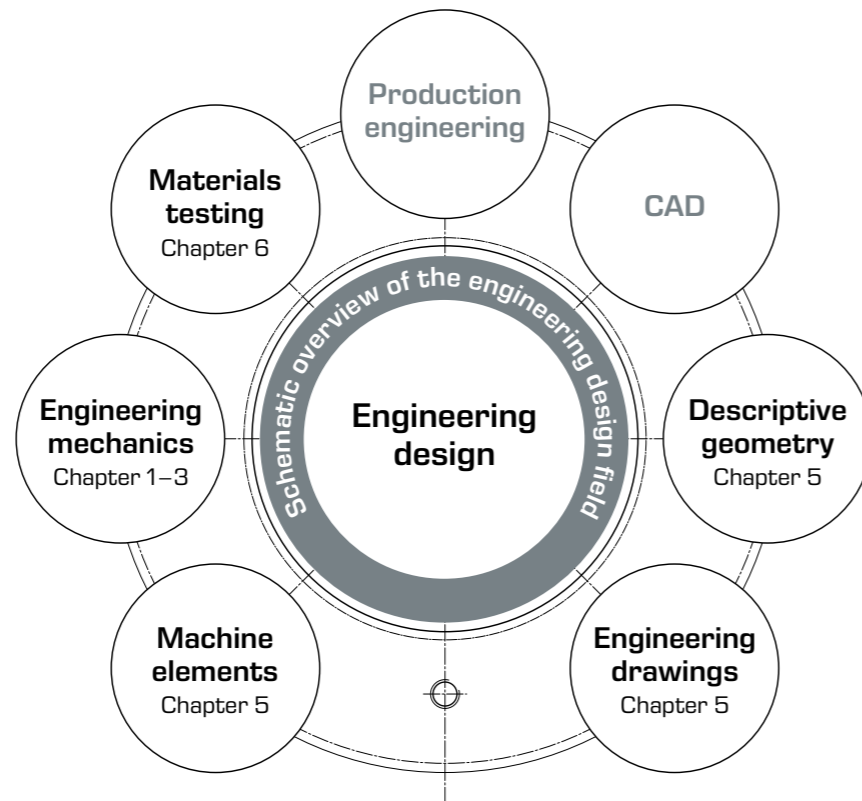

From the idea for a product to its illustration in the form of a production-oriented engineering drawing

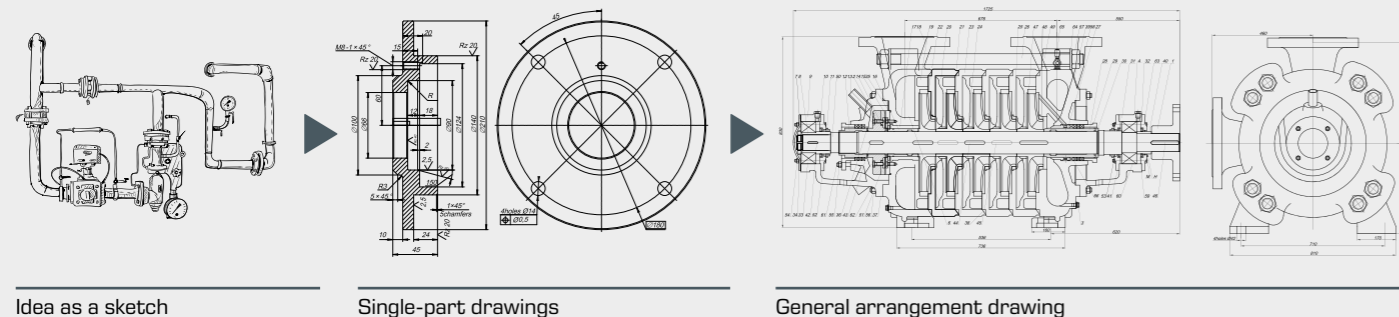

Idea as a sketch

Single-part drawings

General arrangement drawing

Procedure involved in engineering design

Work step	Activity	Result
Observation	<ul style="list-style-type: none"> ■ description of the problem ■ acquisition of information ■ creation of a requirements list 	Technical specifications
Design	<ul style="list-style-type: none"> ■ abstract and formulate the problem ■ description of the function ■ search for solution principles ■ investigate possible solution ■ define a basic solution 	Circuit diagram, hand-drawn sketch or rough scale drawing
Draft	<ul style="list-style-type: none"> ■ sketch rough draft ■ perform calculations ■ design geometry, starting from the basic solution ■ select the materials ■ select the machine elements, standard parts and supplied parts for the function ■ create a design drawing with data on components or machine elements and strength calculation ■ define assemblies 	Calculations, design drawing
Development	<ul style="list-style-type: none"> ■ prepare the single-part drawings ■ create lists of parts ■ review manufacturing options and the final costs ■ define the instructions for manufacturing and assembly ■ create operating instructions and documentation 	Engineering drawings, lists of parts, assembly instructions

Engineering design education

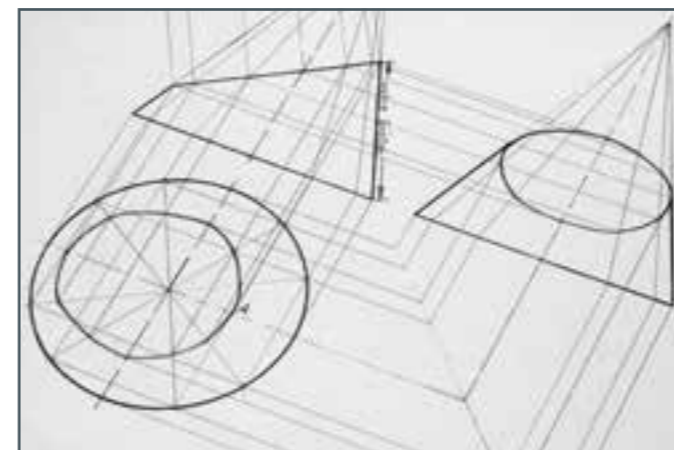

To start with, the fundamentals of engineering design are taught, such as descriptive geometry, engineering drawing and standardisation. Then we look at machine elements such as screws, shafts, bearings and gears. The aim is to learn what

these components do and how they work. Based on this knowledge, engineering design exercises can be solved.

Engineering drawing and cutaway models



Engineering drawings present a very abstract image of the components or devices with precise specifications. Using geometric and graphical features such as lines and symbols, as well as alphanumeric characters such as digits and letters, a three-dimensional object is described in two dimensions.

Reading and understanding engineering drawings is a fundamental element in the development of professional competence in all engineering disciplines.

Engineering drawing course

The engineering drawing course is composed of two modules. The first module uses geometric models to develop spatial concepts. The second offers the application of rules and standards in technical communication with selected components, cutaway models and assembly exercises that help with the understanding of functions and assembly. An important educational objective of the course is the presentation of specific

applications and the use of real workpieces and standard parts. This is intended to develop engineering-related communication skills. The actual drawing tasks are developed from a larger technological environment.

Model sets for developing spatial concepts



Model constructed in a corner of a room with folded representations

The representation of a body and the "folding" (or changing of the direction of projection) causes difficulties for many students. It requires a large capacity for abstraction and spatial imagination. These skills can be developed with appropriate training. The GUNT geometric models have been designed to teach spa-

tial imagination. These skills are vital for creating perspective drawings and interpreting drawings and sketches, known as the ability to "read" drawings.

Components and assembly exercises for teaching rules and standards in engineering communication

The creation of an engineering drawing, whether manually or computer assisted, follows binding rules – the drafting standards – that do not permit any ambiguity. The drafting standards of the DIN (Deutsches Institut für Normung, German Institute for Standardization) take account of the standards and recommendations of the ISO (International Organization for Standardization) and are therefore applicable internationally. The published drafting standards, identified by the name DIN, ISO or EN ISO, include, for example:

- precise identification and use of line styles, hatches and colours as well as the representation of views and sections
- isometric and diametric representation; simplified representation
- dimension inscriptions, tolerance abbreviations
- drawing-sheet formats, title blocks, standard font
- fits; basic terms of tolerances and fits
- surface characteristics

Standards-compliant engineering drawing

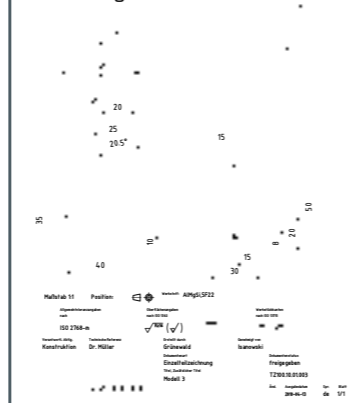

Cutaway models and assembly exercises to demonstrate the functions

Using assembly exercises links engineering communication to the associated technical operations such as assembly and manufacturing. In this way, theoretical and practical learning content supports the skills of reading and understanding drawings, graphs and schematics.

Real understanding can only be achieved by doing and by one's own drawing activity.

Engineering animations such as cutaway models are ideally suited to representing processes and functions. GUNT uses up-to-date original parts for its cutaway models. Movement and switching functions are maintained.

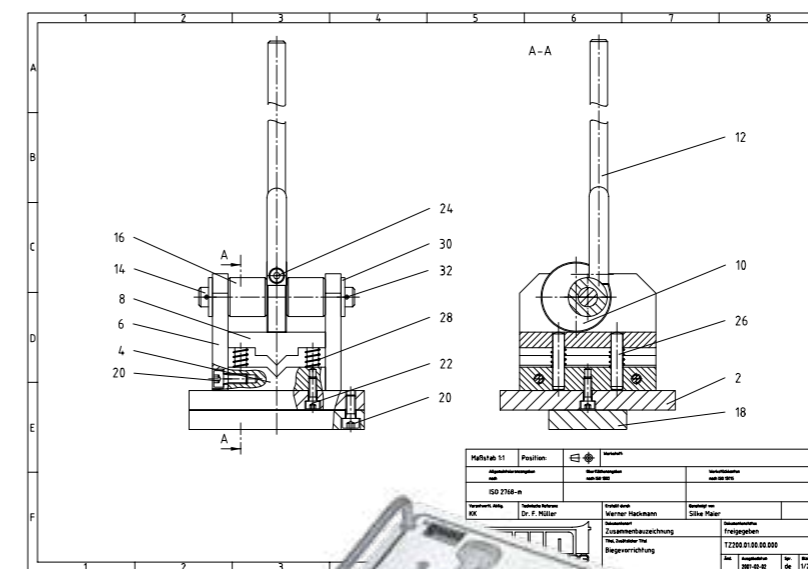

General arrangement drawing

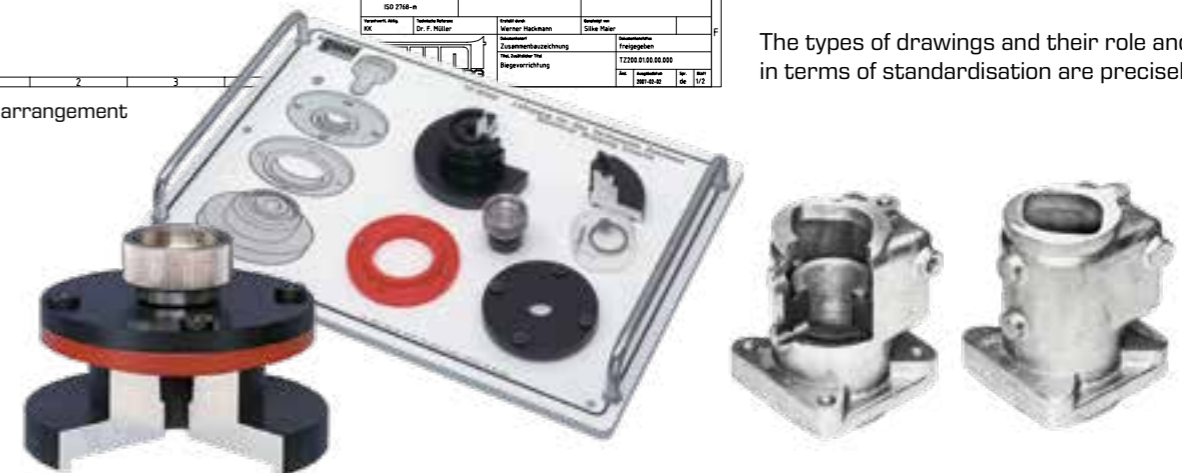

The components and assembly exercises of GUNT teach:

- the standards-compliant execution of engineering drawings
- the recognition of standardised representations
- the understanding of contexts of individual components

The ability to read drawings is demonstrated using:

- general arrangement drawings and exploded drawings
- raw casting drawing, production drawings

The types of drawings and their role and content in terms of standardisation are precisely explained.



Assembled lever press

TZ 100

Engineering drawing: three-dimensional display



Description

- **GUNT course: engineering drawing**
- **model set for developing spatial concepts**
- **fundamentals of three-dimensional display**

In order to describe a spatial body adequately and thereby fulfil a basic principle of exact replication and repeatable production, several views of the body are usually necessary. To do this, bodies are shown in three planes: front view, side view and plan or bottom view. The presentation follows fixed rules that are defined in the standards. Even for simple bodies, the presentation in three planes requires a considerable degree of abstraction ability and spatial imagination on the part of students. This ability is a prerequisite for both creating and interpreting engineering drawings or sketches and is taught by means of geometric models.

The TZ 100 model set provides a learning concept with which to introduce students to the discipline of descriptive geometry.

A corner of a room, comprising three flat Plexiglas sheets, holds the models. The corresponding view is inserted into each plane of the room corner, so that it is possible to directly compare model (workpiece) and drawing.

A total of ten models of varying difficulty are included. One model is made of Plexiglas in order to develop an understanding of hidden edges. The other models are made of aluminium.

The models are precision-manufactured so that measuring exercises can also be conducted. All parts are clearly laid out and well protected in a storage system.

The exercises are ideally performed by the students themselves. Two students can comfortably work with one model set.

The instructional materials include a complete set of drawings. A representation in three views, the 3D view and the production drawing are included for each model.

Learning objectives/experiments

- familiarisation with three-dimensional display as a basic principle of engineering drawing
- step-by-step development of spatial thinking: from the concrete situation to the abstract representation in an engineering drawing
- measuring exercises



Room corner made of three Plexiglas planes with inlaid drawing and a prismatic model

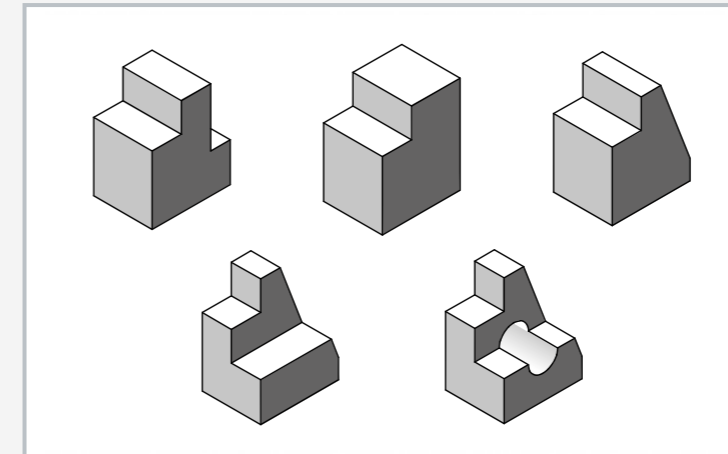

Prismatic models

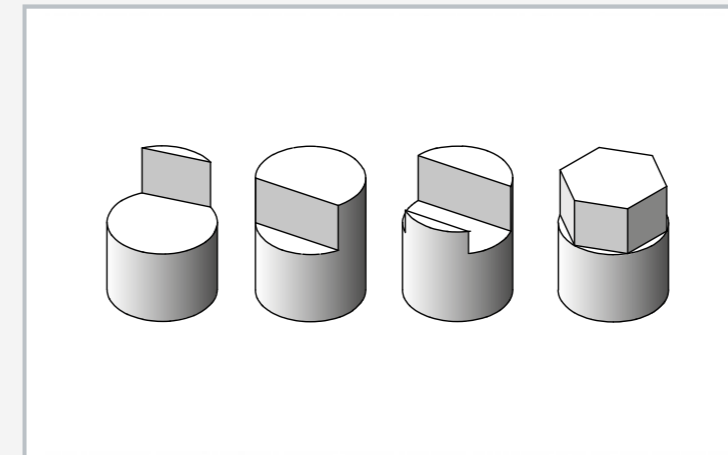

Cylindrical models

Specification

- [1] set of models from the descriptive geometry discipline to develop spatial concepts
- [2] introduction to engineering drawing
- [3] precision manufacture of the models allows measuring exercises
- [4] room corner comprising three Plexiglas planes
- [5] 9 aluminium geometric models; cylindrical and prismatic shapes
- [6] 1 Plexiglas model
- [7] storage system for parts

Technical data

5 prismatic models
■ LxWxH: 40x30x50mm

4 cylindrical models
■ ØxH: 40x50mm

1 transparent model
■ LxWxH: 40x30x50mm

3 Plexiglas planes
■ LxWxH: 100x100x100mm

LxWxH: 335x240x71mm (storage system)
Weight: approx. 3kg

Scope of delivery

- 1 storage system with foam inlay
- 1 set with 10 geometric models
- 3 Plexiglas planes for constructing a room corner
- 1 rod for holding the models
- 1 paper punch
- 1 set of instructional material, complete set of drawings included

TZ 200.61**Engineering drawing: rotationally symmetrical components****Description**

- **GUNT course: engineering drawing**
- **consists of drilling jig and workpiece**
- **introduction to sectional views**

Reading and understanding complex engineering drawings are core skills. They are at least equivalent to drawing ability itself, and are the aim of this GUNT course. The use of concrete applications and real-world workpieces and standard parts is intended to develop engineering communication skills. The actual drawing tasks are developed from a larger technological environment.

TZ 200.61 provides an introduction to the graphical representation of rotationally symmetrical components and the representation of sections. The central element is a drilling jig that can be used, in this case, to drill into a bearing cap. A quarter has been cut out of the base of the drilling jig. This illustrates the concepts of "section" and "half-section".

The cut-out quarter is also provided on the base plate, so that the difficult topic of sectional views can be demonstrated clearly.

All parts are clearly arranged on a base plate. An exploded view, attached to the base plate, illustrates the overall arrangement.

The manufactured parts are precision-manufactured and therefore are also suitable for measuring exercises.

Ideally, the parts should be used in the classroom as an exercise. Two or three students can work meaningfully with one kit.

Learning objectives/experiments

- introduction to graphical representation of rotationally symmetrical components
- familiarisation with sectional views: full section and half section
- dimensioning of rotating parts and threads
- production engineering aspects
 - ▶ devices as aids for drilling and reaming
 - ▶ complete machining on modern tooling machines
 - ▶ tolerances, fits, surface specifications
- classification of the workpiece (bearing cap) in a larger technological context

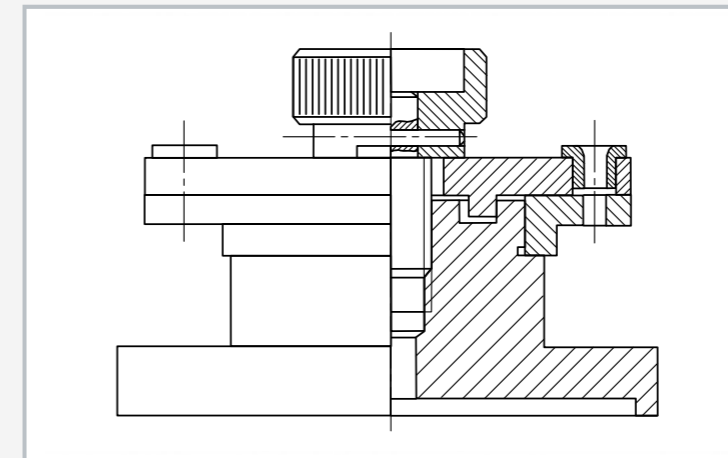

Sectional view of the drilling jig with the workpiece to be drilled (bearing cap)



Assembled drilling jig with workpiece:
1 fastening screw, 2 drill plate, 3 drill bush, 4 workpiece (bearing cap), 5 base

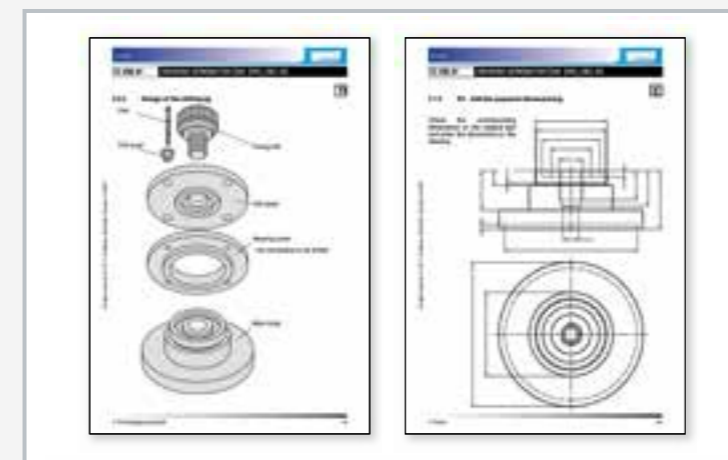

Instructional material

Specification

- [1] part of the GUNT course on engineering drawing
- [2] rotationally symmetrical components using the example of a practical drilling jig for machining of a workpiece (bearing cap)
- [3] base of the drilling jig prepared as a half section
- [4] all individual parts of the drilling jig precision-manufactured from aluminium
- [5] PVC bearing cap as workpiece
- [6] base plate with printed exploded drawing
- [7] storage system for parts
- [8] accompanying instructional material considers practical and interdisciplinary forms of teaching

Technical data

LxWxH: 420x300x75mm (storage system)
Weight: approx. 2kg

Scope of delivery

- 1 base plate with the individual parts of the drilling jig
- 1 workpiece (bearing cap)
- 1 set of standard parts (drill bush, pin, O-ring)
- 1 set of instructional material

TZ 200.02

Engineering drawing: casting



Machined (left) and raw casting (right)

Learning objectives/experiments

- engineering drawing
 - ▶ cast drawings and their features: machining allowances, mould draughts, shrinkage, sectional views
 - ▶ from casting to finished part: production-based and standards-compliant dimensioning for the subsequent machining
- technology
 - ▶ manufacture of castings in sand casting; production processes
 - ▶ tool and machine selection; longitudinal measuring exercises
 - ▶ machine elements and their function

Specification

- [1] part of the GUNT course on engineering drawing
- [2] graphical representations: from raw casting to finished machine part
- [3] 2 models showing the development of the manufacturing process: 1 raw casting, 1 cutaway model
- [4] accompanying instructional material considers practical and interdisciplinary forms of teaching

Technical data

LxWxH: 100x100x125mm (per model)
Weight: approx. 3kg

Scope of delivery

- 2 models
- 1 set of instructional material

Description

- **GUNT course: engineering drawing**
- **from raw casting to finished machine part**

A bearing housing made from sand-cast aluminium is used in teaching as an example to illustrate the subject of cast parts in a detailed and practical way. TZ 200.02 comprises a raw casting of a bearing housing, manufactured and polished in a foundry, and a finished part of the same bearing housing, which has been machined after being cast. The machined part has also been prepared as a cutaway model.

The two components can be used to describe the process from forming to machining. An ideal learning situation would be to allow two or three students to study the model set together.

TZ 200.08

Engineering drawing: safety catch

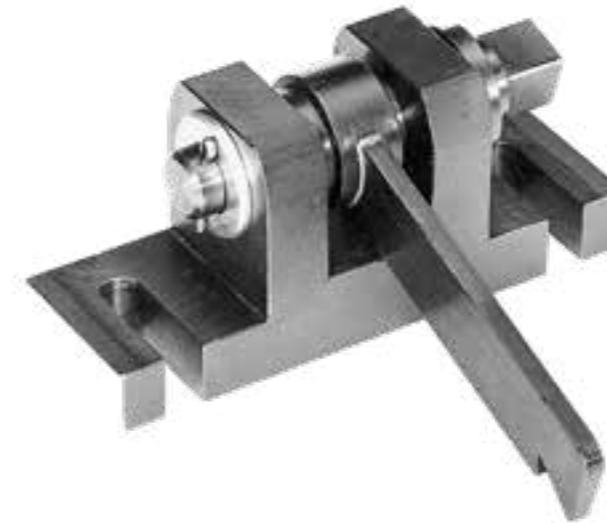

Learning objectives/experiments

- readily understandable engineering drawings and lists of parts
- production-based and standards-compliant representation of single parts: dimensioning, surface and tolerance specifications
- technological aspects: material selection, functions, production processes, work planning and more

Specification

- [1] part of the GUNT course on engineering drawing
- [2] practical functional model of a safety catch
- [3] all production parts made from precision-manufactured burnished steel surfaces
- [4] accompanying instructional material considers practical and interdisciplinary forms of teaching

Technical data

LxWxH: 130x100x60mm
Weight: approx. 1kg

Scope of delivery

- 1 safety catch
- 1 set of instructional material

Description

- **GUNT course: engineering drawing**
- **complete production-ready drawing set**

The model of a safety catch is part of the extensive GUNT course providing an introduction to engineering drawing. The didactic approach is based on a real-world component and systematically develops transferable learning content.

The manufactured parts are precision-manufactured and therefore also suitable for measuring exercises. The surfaces of the manufactured parts are burnished to prevent corrosion.

Ideally, the part should be used in the classroom as an exercise. Two or three students can work meaningfully with one kit.

TZ 300

Assembly of lever press



Description

- GUNT course: engineering drawing
- lever press as assembly kit
- exercise for interdisciplinary teaching

A drawing is the most important means of information and communication in engineering. The ability to read and understand drawings, graphics and schematics is a fundamental element in the development of professional competence in all engineering disciplines. Linking engineering communication to the associated technical operations such as assembly structure, work plans and manufacturing is just as important.

The TZ 300 assembly kit is an interdisciplinary and practical project. In addition to the primary learning area of "engineering drawing", it is also possible to deal with the topics of machine elements, assembly processes and in particular production engineering.

The assembly kit includes all single parts required to assemble a functional lever press. The parts are clearly displayed on a base plate. All single parts and the corresponding drawings are available in a standards-compliant and practical form.

The manufactured parts are precision-manufactured from original materials and with common tolerances and surfaces. The surfaces of the manufactured parts are burnished to prevent corrosion. All parts are clearly laid out and well protected in a storage system. Multiple storage systems can be stacked on top of each other, allowing space-saving storage.

Usage in the classroom should ideally be as a practical exercise, in which two or three students can work comfortably on one assembly kit.

Learning objectives/experiments

- introduction to engineering drawing
 - ▶ read and understand engineering drawings
 - ▶ three-dimensional display
 - ▶ sectional views
 - ▶ drawing types
 - ▶ 3D representation
 - ▶ lists of parts
 - ▶ dimensioning
 - ▶ surface and tolerance specifications
 - ▶ difference between standard and production parts
 - ▶ materials specifications
- planning and execution of simple assembly operations
 - ▶ plan and describe operations
 - ▶ evaluate results
- measuring exercises
 - ▶ longitudinal measurements
 - ▶ angular measurements
- manufacturing processes
 - ▶ working examples of handmade production and production on machine tools

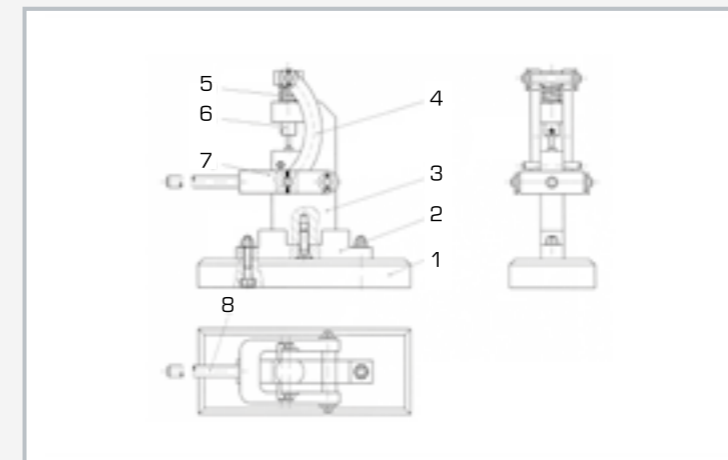

1 base plate, 2 foot, 3 stand, 4 arch, 5 compression spring, 6 pressure pin, 7 fork, 8 handle

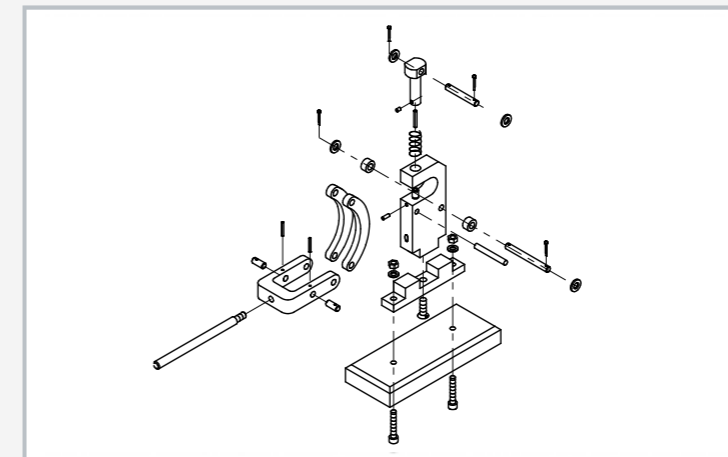

Exploded drawing of the lever press



Functional groups of the lever press: fork, pressure pin, main body

Specification

- [1] part of the GUNT course on engineering drawing
- [2] assembly kit of a functional lever press
- [3] all production parts of the lever press made from steel, precision-manufactured, burnished surfaces
- [4] storage system for parts
- [5] multiple storage systems can be stacked on top of each other
- [6] accompanying instructional material considers practical and interdisciplinary forms of teaching

Technical data

LxWxH: 420x300x70mm (storage system)

Weight: approx. 3kg

Scope of delivery

- 1 storage system with the individual parts of the lever press
- 1 set of tools for assembly and disassembly
- 1 set of small parts
- 1 set of instructional material

TZ 200.11

Assembly of bending device

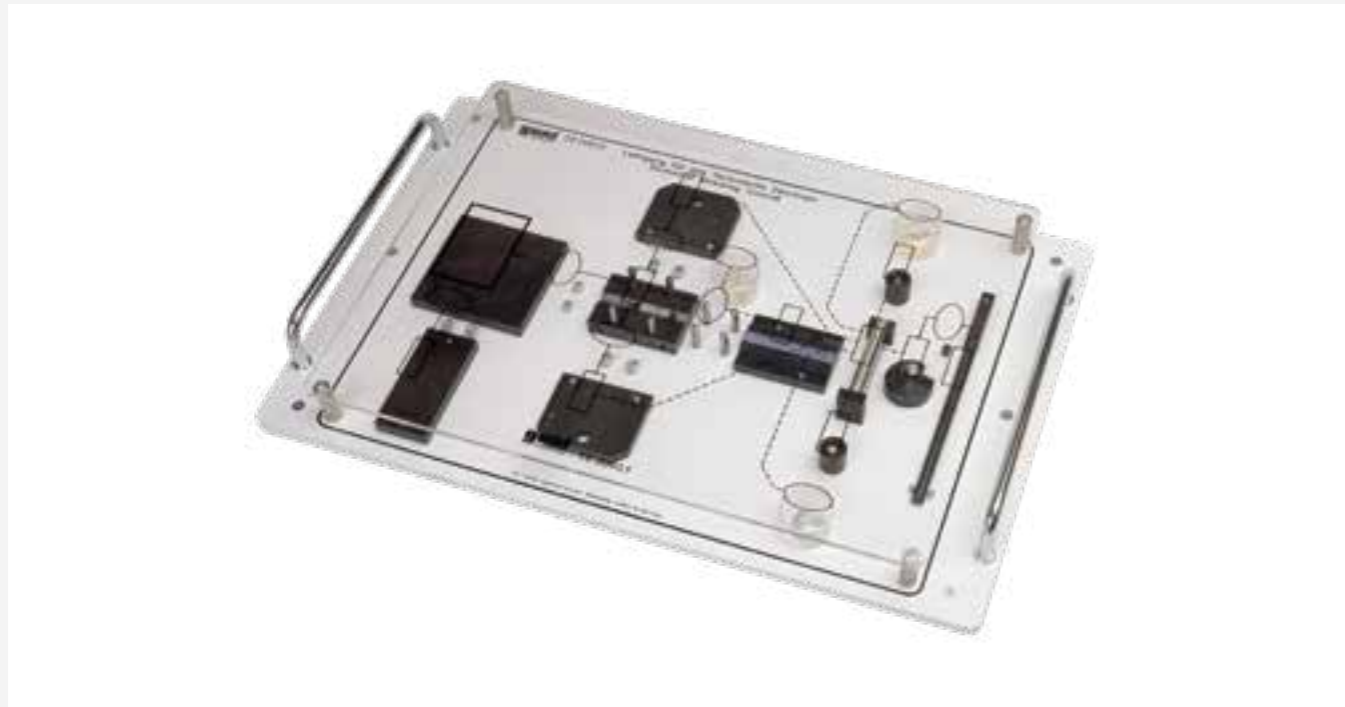

Description

- GUNT course: engineering drawing
- bending device as assembly kit
- exercise for interdisciplinary teaching

A drawing is the most important means of information and communication in engineering. The ability to read and understand drawings, graphics and schematics is a fundamental element in the development of professional competence in all engineering disciplines. Linking engineering communication to the associated technical operations such as assembly structure, work plans and manufacturing is just as important.

The TZ 200.11 assembly kit is an interdisciplinary and practical project. In addition to the primary learning area of "engineering drawing", it is also possible to deal with topics such as assembly planning and execution as well as measuring exercises. The assembly kit includes all single parts required to assemble a functional bending device.

The parts are grouped on a base plate so that individual assembly sequences are clearly displayed. Above the base plate is a transparent cover plate with a graphical representation of the assembly structure. The graphic symbolizes standard and production parts and displays fixed and moving connections differently. All single parts and the corresponding drawings are available in a standards-compliant and practical form.

The manufactured parts are precision-manufactured from original materials and with common tolerances and surfaces. The surfaces of the manufactured parts are burnished to prevent corrosion. All parts are clearly laid out and well protected in a storage system. Multiple storage systems can be stacked on top of each other, allowing space-saving storage.

Usage in the classroom should ideally be as a practical exercise, in which two or three students can work comfortably on one assembly kit.

Learning objectives/experiments

- introduction to engineering drawing
 - ▶ read and understand engineering drawings
 - ▶ three-dimensional display
 - ▶ sectional views
 - ▶ drawing types
 - ▶ 3D representation
 - ▶ lists of parts
 - ▶ dimensioning
 - ▶ surface and tolerance specifications
 - ▶ difference between standard and production parts
 - ▶ materials specifications
- planning and execution of simple assembly operations
 - ▶ plan and describe operations
 - ▶ evaluate results
- measuring exercises
 - ▶ longitudinal measurements
 - ▶ angular measurements

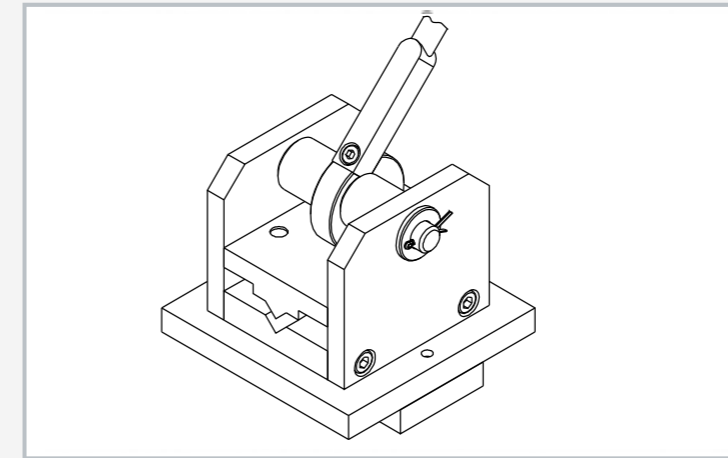

3D representation of the assembled bending device

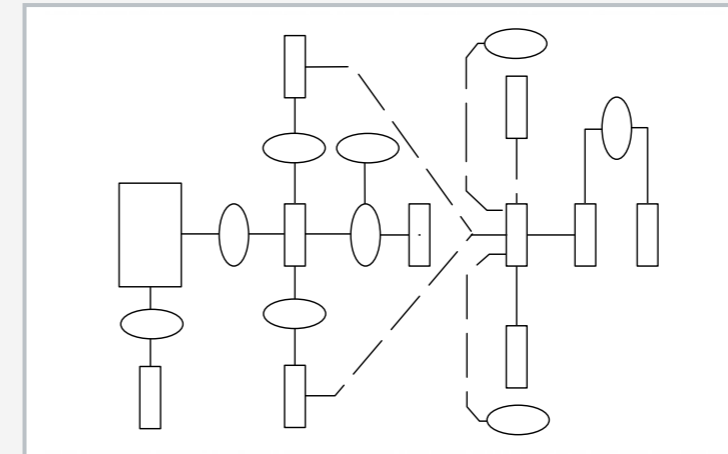

Graphical representation of the assembly structure

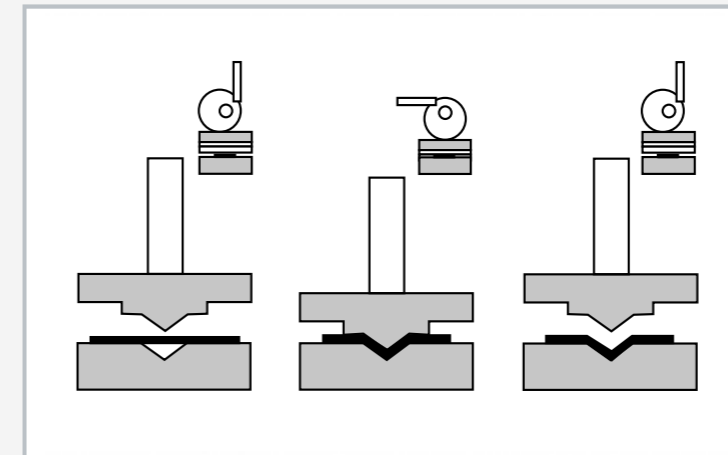

Bending process

Specification

- [1] part of the GUNT course on engineering drawing
- [2] assembly kit of a functional bending device with eccentric operation
- [3] all production parts made from precision-manufactured burnished steel surfaces
- [4] assembly structure on transparent cover plate
- [5] storage system for parts
- [6] multiple storage systems can be stacked on top of each other
- [7] accompanying instructional material considers practical and interdisciplinary forms of teaching

Technical data

LxWxH: 540x350x75mm (storage system)
Weight: approx. 6kg

Scope of delivery

- 1 storage system with the individual parts of the bending device
- 1 cover plate with assembly structure
- 1 set of tools for assembly and disassembly
- 1 set of instructional material

TZ 200.71

Assembly of lever shears



Description

- GUNT course: engineering drawing
- lever shears as assembly kit
- exercise for interdisciplinary teaching

A drawing is the most important means of information and communication in engineering. The ability to read and understand drawings, graphics and schematics is a fundamental element in the development of professional competence in all engineering disciplines. Linking engineering communication to the associated technical operations such as assembly structure, work plans and manufacturing is just as important.

The TZ 200.71 assembly kit is an interdisciplinary and practical project. In addition to the primary learning area of "engineering drawing", it is also possible to deal with the topic of assembly processes, in particular production engineering.

The assembly kit includes all single parts required to assemble functional lever shears. The parts are grouped on a base plate so that individual assembly sequences are clearly displayed.

Above the base plate is a transparent cover plate with a graphical representation of the assembly structure.

The graphic symbolizes standard and production parts and displays fixed and moving connections differently. All single parts and the corresponding drawings are available in a standards-compliant and practical form.

The manufactured parts are precision-manufactured from original materials and with common tolerances and surfaces. The surfaces of the manufactured parts are burnished to prevent corrosion. All parts are clearly laid out and well protected in a storage system. Multiple storage systems can be stacked on top of each other, allowing space-saving storage.

Usage in the classroom should ideally be as a practical exercise, in which two or three students can work comfortably on one assembly kit.

Learning objectives/experiments

- introduction to engineering drawing
 - ▶ read and understand engineering drawings
 - ▶ three-dimensional display
 - ▶ sectional views
 - ▶ drawing types
 - ▶ 3D representation
 - ▶ lists of parts
 - ▶ dimensioning
 - ▶ surface and tolerance specifications
 - ▶ difference between standard and production parts
 - ▶ materials specifications
- planning and execution of simple assembly operations
 - ▶ plan and describe operations
 - ▶ evaluate results
- measuring exercises
 - ▶ longitudinal measurements
 - ▶ angular measurements
- manufacturing processes
 - ▶ working examples of handmade production and production on machine tools

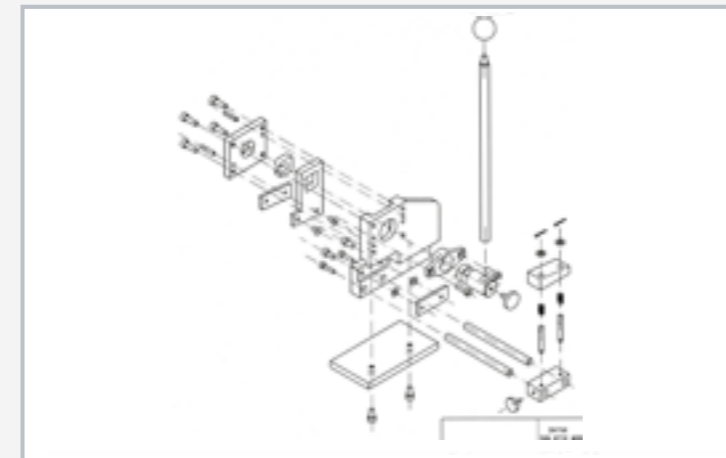

Exploded drawing of lever shears

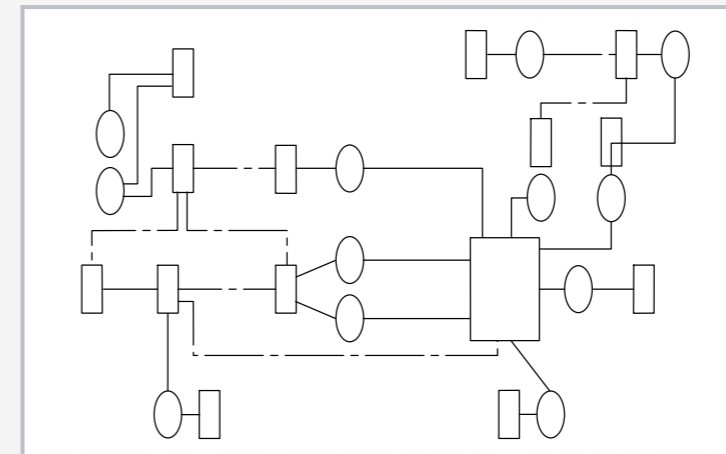

Graphical representation of the assembly structure



Functional groups of the lever shears: shear body, base, stop

Specification

- [1] part of the GUNT course on engineering drawing
- [2] assembly kit of functional lever shears
- [3] all production parts of the lever shears made from precision-manufactured burnished steel surfaces
- [4] assembly structure on transparent cover plate
- [5] storage system for parts
- [6] multiple storage systems can be stacked on top of each other
- [7] accompanying instructional material considers practical and interdisciplinary forms of teaching

Technical data

LxWxH: 540x350x70mm (storage system)
Weight: approx. 7kg

Scope of delivery

- 1 Weight: approx. with the individual parts of the lever shears
- 1 cover plate with assembly structure
- 1 set of tools for assembly and disassembly
- 1 set of small parts
- 1 set of instructional material

GL 300.01

Cutaway model: worm gear

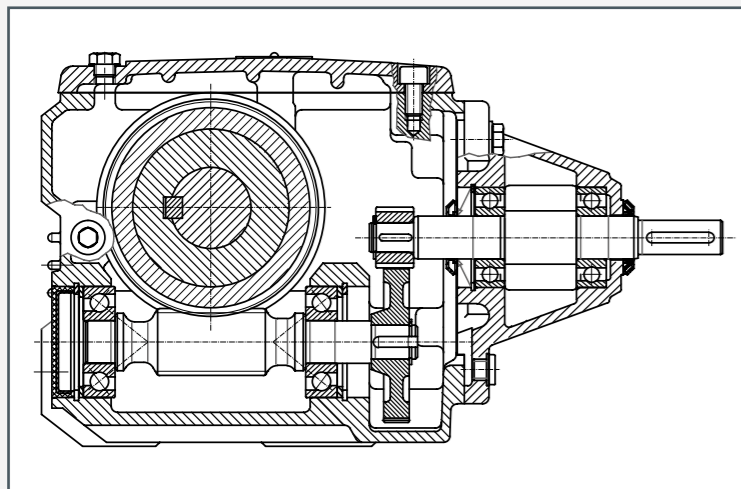

The technical drawings are part of the instructional material.

Manually operated open samples of various drive components and elements

- view of the details and function of the components
- despite the cut outs the movement functions are completely retained
- operation using a hand crank

These models are fitted to sturdy metal base plates. Lifting handles make the models easier to carry. Technical descriptions and sectional drawings are included so that calculations and design aspects can be used as an educational topic.

GL 300.02
Cutaway model:
mitre gear**GL 300.03**
Cutaway model:
spur gear**GL 300.04**
Cutaway model:
two-stage
spur gear**GL 300.05**
Cutaway model:
planetary
gear**GL 300.06**
Cutaway model:
variable speed
belt drive**GL 300.07**
Cutaway model:
control gear**GL 300.08**
Cutaway model:
multiple-disk
clutch**GL 300.12**
Cutaway model:
pedestal bearing

Machine elements

Components of a technical application that fulfil certain functions in structures are known as machine elements. Machine elements can be both single components and assemblies:

- individual parts such as screws, bolts or gears
- assemblies consisting of individual machine elements, such as couplings, ball bearings, transmissions or valves

An individual machine element always performs the same function, even though it is used in very different structures.

Simple machine elements such as screws, cylinder pins, feather keys or seals are defined according to standards and therefore can be exchanged without difficulty. More complex machine elements such as bearings, couplings, gears or shafts are standardised in only certain important properties, such as main dimensions or flanges, and as such are not fully interchangeable.

Classification of machine elements

Some machine elements can perform different tasks. For example, couplings can be used as linking and/or transmission elements and shafts can be used for bearing and/or transmission.

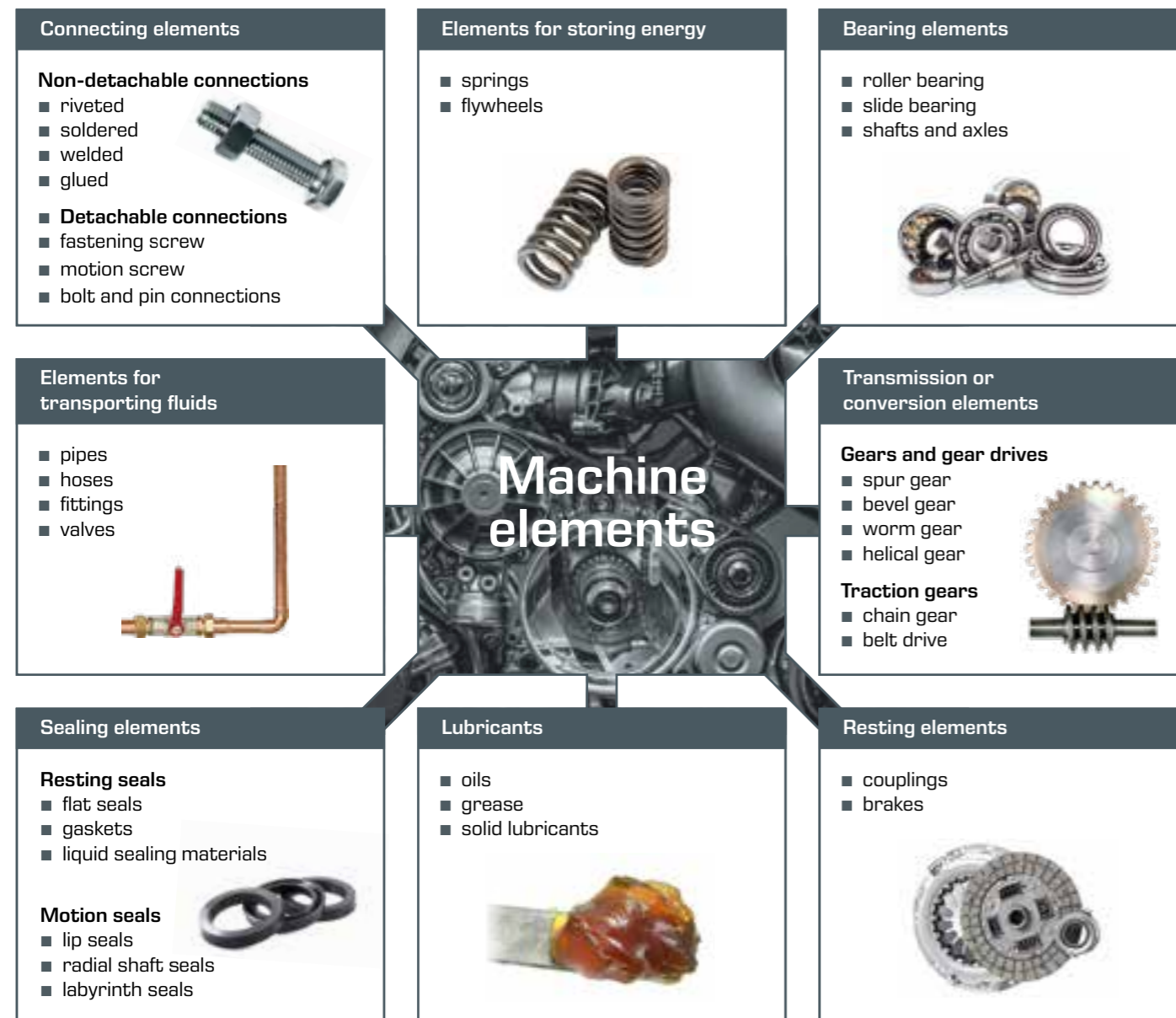

This section presents the following machine elements:

- various connecting elements
- roller bearings
- various types of gears

Connecting elements



Connecting elements are used when the components in the machine are intended to be fixed firmly to each other. Fixing screws, rivets and studs are discrete elements that are usually detachable and can be reused.

Screws are the most commonly used machine elements and are classified according to their function: **fastening screws** connect two or more parts firmly to each other and can be detached. **Motion screws** convert rotary motion into linear motion and are used under load following assembly.

Bearing elements



Bearing elements can absorb and divert forces, secure rotary motion of shafts and axles, and allow axial guiding of shafts. A distinction is made between slide bearings and roller bearings depending on the design. In **slide bearings**, the opposing, movable parts are in contact with each other. This sliding is usually facilitated by a lubricating film. Slide bearings allow an optimum transfer of force over the entire area of the touching surfaces.

With **roller bearings**, components move by rolling, which therefore reduces friction. In roller bearings, an outer race and an inner race roll against each other. Typical rolling elements are cylinders and spheres. So that the rolling elements do not touch each other, cages are used to keep the cylinders or spheres separate.

Transmission or conversion elements



Complex machine elements used to alter the motion variables of path, velocity and acceleration are known as conversion elements or gears. In a gear drive, positively locking **gears** transfer the rotary motion from one shaft to another. In a traction drive, the rotary motion is transferred between two shafts by

means of a traction gear. Here, a distinction is made between non-positive traction drives (**belt drive**) and positive traction drives (**chain or toothed belt drive**).

MG 901

Nuts and bolts kit



Learning objectives/experiments

- familiarisation with the most important screws and nuts used in mechanical engineering and their specific applications
- familiarisation with relevant standardised designations and terms including their graphical representations

Specification

- [1] kit of screws and nuts
- [2] 42 standard parts arranged clearly on an aluminium plate
- [3] plate with screen print
- [4] shown in the screen print: graphic representation and DIN designation
- [5] all parts arranged clearly in the storage system
- [6] multiple storage systems can be stacked on top of each other

Technical data

Aluminium plate, LxW: 350x255mm
Screws: C4,8, K4,8, M6, M8, M10
Nuts: M6, M8, M10

LxWxH: 500x350x110mm (storage system)
Weight: approx. 3kg

Scope of delivery

- 1 complete kit, arranged in storage system
- 1 set of instructional material

Description

- **extensive kit comprising the most important screws and nuts used in mechanical engineering**
- **standard designations, terms and graphical representation**

Screws and nuts are standardised machine elements that are classified as detachable elements. These connecting elements are used when components of a machine need to be firmly fixed to each other. Different screws and nuts are used depending on the application.

This kit is used for demonstration and information. It is not designed for performing exercises or experiments. The original standard parts are screwed clearly into an aluminium plate. The symbols on the plate show the DIN and standard designation of the relevant part, in addition to the correct graphical representation.

The kit is arranged clearly in a storage system.

MG 903

Screw-locking devices kit



Learning objectives/experiments

- familiarisation with screw-locking devices and their specific applications
- familiarisation with relevant standardised designations and terms including the graphical representation

Specification

- [1] kit of screw-locking devices
- [2] 18 assembled screw-locking devices arranged clearly on an aluminium plate
- [3] transparent container with 18 compartments, each containing 10 pieces of the different screw-locking devices
- [4] all parts arranged clearly in the storage system
- [5] multiple storage systems can be stacked on top of each other

Technical data

Aluminium plate, LxW: 238x100mm
Locking devices for M6

LxWxH: 510x360x120mm (storage system)
Weight: approx. 3kg

Scope of delivery

- 1 complete kit, arranged in storage system
- 1 set of instructional material

Description

- **extensive kit of screw-locking devices**
- **standardised designations, terms and applications**

Screw-locking devices are designed to prevent the unwanted loosening of screw connections because of external influences such as vibration or corrosion. The lock machine element is added to a screw connection by the manufacturer as an additional component.

This kit is used for demonstration and information. It is not designed for performing exercises or experiments. Screw-locking devices are shown in their installed state on an aluminium plate. A transparent box contains a large number of Screw-locking devices.

The kit is arranged clearly in a storage system.

MG 905

Thread types kit



Learning objectives/experiments

- familiarisation with the most important thread types used in mechanical engineering and their specific applications
- use the thread gauge to determine the thread type

Specification

- [1] kit of thread types
- [2] 8 thread types, arranged clearly
- [3] cut-out sections make thread flanks visible
- [4] galvanised parts
- [5] thread gauge for determining thread type
- [6] all parts arranged clearly in the storage system
- [7] multiple storage systems can be stacked on top of each other

Technical data

Thread size: 24mm
Thread gauge for external and internal thread

- metric ISO thread
- Whitworth thread
- Whitworth pipe thread

LxWxH: 500x350x110mm (storage system) Weight: approx. 3kg

Scope of delivery

- 1 complete kit, arranged in storage system
- 1 set of instructional material

Description

- **extensive teaching kit of the most important thread types used in mechanical engineering**
- **standardised designations, terms and specific applications**

Threads are the basis for detachable connections, such as screws with external threads and nuts with internal threads. A number of thread types have been developed over time, depending on the application and loads that a thread has to withstand. Standards guarantee the function of paired components with internal and external threads.

This kit is used for demonstration and information. It is not designed for performing exercises or experiments. Different bolt and nut threads are shown. The thread flanks are made visible by cut-out sections. A thread gauge allows you to determine the thread type and size.

The kit is arranged clearly in a storage system.

TM 320

Screw connections testing



Learning objectives/experiments

- axial tension force in a bolt joint dependent on the tightening torque or the elastic deformation of a slotted block
- measurement of the breakaway torque, including for different fitting situations of the bolt joint
- measurement of thread friction and overall friction

Specification

- [1] experiment on the correlation between the tension force and tightening torque of bolts
- [2] bolt size M8x100, wrench jaw size 13mm
- [3] elastic deformation of a slotted block by the bolt
- [4] determining the tightening and breakaway torque with a mechanical torque measuring device
- [5] 2 dial gauges
- [6] sensitive torque setting by hand wheel

Technical data

Tension force

- max. 40kN

Force/travel constant

- 20kN/mm (on slotted block)

Max. tightening torque

- 40Nm

Torque/travel constant

- 10Nm/mm (on torque measuring device)

Dial gauge

- 0...10mm
- graduation: 0,01mm

LxWxH: 450x400x260mm
Weight: approx. 27kg

Scope of delivery

- 1 experimental unit
- 1 set of bolts in transparent container
- 1 set of instructional material

Description

- **correlation between tightening torque and tension force on standardised bolts**
- **breakaway torque of a bolt joint**

The main element of the unit is a slotted, elastically deformable steel block. By tightening the bolt joint, the slotted area is deformed, thereby generating an axial tension force in the bolt. The resulting deformation is recorded by a mechanical dial gauge, and is directly related to the bolt tension force generated.

The bolt joint is tightened and slackened using a special torque wrench, which can be set sensitively with the aid of a threaded spindle. By using an axial bearing, the head friction of the bolt can be largely excluded, so that only the friction of the threaded joint is measured.

TM 310

Thread testing



Learning objectives/experiments

- determine the friction coefficient of a steel threaded spindle in conjunction with
 - ▶ a cast iron nut
 - ▶ a bronze nut
 - ▶ a plastic nut
- determine the relevant thread efficiency

Specification

- [1] investigation of the thread efficiency with different thread-material pairings
- [2] nuts made of cast iron, bronze and plastic
- [3] spindles with trapezoidal thread, varying pitch
- [4] generate torque using pulley with spring balance and cable
- [5] load via graduated loads

Technical data

Spindle thread
 ■ TR30x6 and TR30x12P6

Rotary plate
 ■ diameter: 140mm

Spring balance
 ■ 0...5N
 ■ graduation: 0,05N

Weight
 ■ 1x 10N
 ■ 1x 20N

LxWxH: 300x300x300mm
 Weight: approx. 15kg

Scope of delivery

- 1 experimental unit
- 1 set of instructional material

Description

■ determine the thread efficiency with different thread-material pairings

The main elements of this experimental unit are a perpendicular pair of thread spindle and nut. A moment is exerted on the spindle by means of a pulley, using a spring balance and cable. Additional weights on the rotary plate influence the axial load of the thread.

Two spindles with trapezoidal threads of different pitch are included. The experimental unit contains three long nuts made of various materials with single pitch and a cast iron nut with double pitch.

The measured values can be used to determine and compare the threads efficiencies.

MG 911

Roller bearings kit



Learning objectives/experiments

- familiarisation with the most important roller bearing types used in mechanical engineering and their specific applications
- familiarisation with relevant standardised designations and terms
- discussion of applications

Specification

- [1] roller bearings kit
- [2] 13 roller bearings, arranged clearly: 5 roller bearings and 8 ball bearings
- [3] 2 axial bearings / 11 radial bearings
- [4] all parts arranged clearly in the storage system
- [5] multiple storage systems can be stacked on top of each other

Technical data

Bearing dimensions
 ■ inner diameter: Ø 20mm
 ■ outer diameter: Ø 35, 40, 42, 47, 52mm
 ■ bearing width: H=8, 10, 12, 14, 15, 18, 47mm

LxWxH: 500x350x110mm (storage system)
 Weight: approx. 2kg

Scope of delivery

- 1 complete kit, arranged in storage system
- 1 set of instructional material

Description

■ extensive teaching kit of the most important roller bearings used in mechanical engineering

■ standardised designations, terms and applications

Roller bearings are standardised machine elements that are classified as guide and bearing elements. They are responsible for guiding rotating shafts or axles in stationary components and transferring radial and axial forces but not torque. Rolling elements (balls or rollers) are located between mutually movable parts. Roller bearings are classified in different standard series depending on the application.

This kit is used for demonstration and information. It is not designed for performing exercises or experiments. Different roller bearings are shown. The bearings are selected for a shaft size.

The kit is arranged clearly in a storage system.

GL 100

Principle of gear units



Learning objectives/experiments

- principle and differences of belt drives, friction wheels and gear drives
- explanation and demonstration of
 - ▶ gear ratio
 - ▶ pitch
 - ▶ module
 - ▶ function of intermediate gears

Specification

- [1] demonstration of the function of belt drives, friction wheels and gear drives
- [2] plastic pulleys and friction washers
- [3] O-ring as a drive belt
- [4] steel gears
- [5] anodised aluminium profile base frame

Technical data

- Gears, steel
- number of teeth: $z=15, 16, 20$
 - module: 20mm
- Pulleys, plastic
- diameter: $\varnothing=300, \varnothing=320, \varnothing=400\text{mm}$

LxWxH: 1100x320x600mm
Weight: approx. 22kg

Scope of delivery

- 1 experimental unit
- 1 set of instructional material

Description

■ demonstration of function and structure of various gears

Gears are machine elements that are classified as transmission or conversion elements. They are responsible for transferring torque and speed between guiding members such as wheels or pulleys. The motion is transferred either by means of non-positive connections (with gears, friction wheel) or positive connections (with gears, toothed belts, chains).

The GL 100 experimental unit illustrates the function and structure of belt drives, friction wheels and gear drives. Fundamental concepts and relationships, such as transmission ratio, change of direction of rotation, pitch and module or the function of intermediate gears can be explained clearly.

A sturdy anodised aluminium frame forms the base of the unit. The bearings of the wheels are attached to the frame by clamping levers in T-grooves. They are easy to detach and can be moved horizontally, thereby allowing a wealth of different setups.

All experiments are powered by hand. The size of the experimental unit ensures that the experiments are clearly visible even for a larger group of students.

GL 110

Cam mechanism



Learning objectives/experiments

- elevation curves in cam mechanisms
- cams come in different shapes
 - ▶ circular arc, tangent, hollow, asymmetric
 - ▶ optionally with roller plunger, flat plunger or cam follower as engaging member

Specification

- [1] function of cam mechanisms
- [2] 4 different shapes of cam: circular arc, tangent, hollow or asymmetric
- [3] 3 different engaging members: roller plunger, flat plunger or cam follower
- [4] cam and engaging member can be exchanged without tools
- [5] dial gauge for determining the stroke
- [6] angular scale for determining the angle of rotation

Technical data

- Angular scale
- 0...360°
 - graduation: 1°

- Dial gauge for the stroke
- 0...30mm
 - graduation: 0,01mm

LxWxH: 160x160x300mm
Weight: approx. 7kg

Scope of delivery

- 1 experimental unit
- 4 cams in cam shape
- 3 engaging members
- 1 dial gauge
- 1 set of instructional material

Description

■ demonstration and measurement of elevation curves in cam mechanisms

Cam mechanisms are non-uniform translatable gears that help convert uniform rotating drive motions into non-uniform drive motions with or without latching. Generally speaking, cam mechanism consists of cams, engaging members and the frame. The desired movement path is defined by the geometry of the cam and produced by pressing a contour or a profile on the engaging member.

The GL 110 unit is used to clearly demonstrate the function of a cam mechanism. Cams are available in different shapes. A roller plunger, flat plunger or cam follower can be used as the engaging member. The stroke is determined by measuring the travel. An angular scale indicates the corresponding angle of rotation.

TM 123

Spur gear unit



Learning objectives/experiments

- development of the main variables and relationships in a straight-toothed spur gear
 - ▶ velocity ratios in spur gears
 - ▶ gear with intermediate wheel or two-stage gear
 - ▶ influence of gear ratio on friction
 - ▶ determine the efficiency

Specification

- [1] function and design of gear drives
- [2] 4 galvanised steel gear wheels
- [3] 2 anodised aluminium pulleys
- [4] ball-bearing-mounted gears and pulleys
- [5] anodised aluminium base plate

Technical data

- 4 gear wheels
- 2x $\varnothing=126\text{mm}$, 84 teeth
 - 2x $\varnothing=42\text{mm}$, 28 teeth
 - module: $m=2\text{mm}$

Pulleys effective radius: 35mm

- Weights
- 2x 1N (hanger)
 - 2x 0,25N
 - 1x 0,5N
 - 2x 1N
 - 2x 2N
 - 2x 2,5N

LxWxH: 350x150x100mm
Weight: approx. 6kg

Scope of delivery

- 1 experimental unit
- 4 gear wheels
- 2 pulleys
- 1 set of weights
- 1 set of instructional material

Description

■ design and principle of gear drives

Gears and gear drives are machine elements that are classified as transmission or conversion elements. Gears transfer the rotational motion from one shaft to another by means of a positive connection. In a spur gear, the gears are arranged on parallel axes. This type of gear is characterised by its relatively simple construction, since only a few moving parts are used and the external teeth gears are simple to manufacture. Spur gears are robust and highly efficient because of their direct, purely mechanical transmission.

The TM 123 experimental unit illustrates the relationship between the ratio of the number of teeth and the transmission ratio of gears. Simple experiments are used to study the torque conversion in gear pairs and the efficiency of a gear. The forces are generated by weights and can be varied quickly and easily.

TM 124

Worm gear unit



Learning objectives/experiments

- development of the main variables and relationships in a worm gear
 - ▶ investigation of transmission ratio, torque, friction and self-locking
 - ▶ determine the efficiency

Specification

- [1] function and design of worm gears
- [2] bronze worm wheel
- [3] steel worm
- [4] 2 aluminium cable drums
- [5] worm, worm wheel and pulleys mounted on ball bearings
- [6] anodised aluminium base plate

Technical data

- Cable drum
- worm shaft diameter: $\varnothing=40\text{mm}$
 - worm wheel shaft diameter: $\varnothing=120\text{mm}$

- Worm gear
- centre distance: 80mm
 - gear ratio: 30:1
 - module: $m=4\text{mm}$
 - number of gears: 1
 - force transmission: 10

Weights on the worm side

- 1x 50N
- 1x 20N
- 2x 10N
- 1x 10N (hanger with equalising mass)

Weights on worm wheel

- 1x 5N
- 4x 2N
- 1x 1N
- 1x 0,5N
- 1x 0,5N (hanger)

LxWxH: 250x150x200mm
Weight: approx. 22kg

Scope of delivery

- 1 experimental unit
- 1 worm
- 1 worm wheel
- 1 set of weights
- 1 set of instructional material

Description

■ design and principle of worm gears

Worm gears are a category of helical rolling gears that are classified as transmission or conversion elements within machine elements. This type of gear comprises the usual driving worm and the driven worm wheel. Worm gears are quiet and have a damping effect. They are smaller and easier to operate than spur gears or bevel gears of the same performance and gear ratios.

The TM 124 experimental unit is used to study their torque ratios and efficiency. The transmission ratio of the gear can be determined. The basic concepts of toothing such as tooth number and gear number, module, pitch and centre distance are illustrated.

The worm wheel and worm are mounted on ball bearings. The forces are generated by weights and can be varied quickly and easily.

TM 125
Cable winch**Learning objectives/experiments**

- determine
 - ▶ transmission ratio
 - ▶ unwinding rate
 - ▶ angular velocity
 - ▶ efficiency
- behaviour under load

Specification

- [1] function and design of cable winches
- [2] investigation of hoisting rate and force transmission
- [3] demonstration of a return stop
- [4] winding the supporting cable on a cable drum
- [5] movement of loads on the supporting cable
- [6] variation of loads and forces

Technical data

Cable drums

- aluminium
- driving wheel
 - ▶ diameter: 220mm
- driven wheel
 - ▶ diameter: 110mm

Gears

- POM
- small: 12 teeth
- large: 60 teeth
- module 2mm each

Total transmission ratio: 10

Weights on driving wheel

- 1x 5N
- 4x 2N
- 1x 1N
- 1x 0,5N
- 1x 0,5N

Weights on driven wheel

- 1x 50N
- 2x 20N
- 1x 10N

LxWxH: 270x200x250mm
Weight: approx. 19kg**Scope of delivery**

- 1 experimental unit
- 2 cable drums
- 1 set of weights
- 1 set of instructional material

Description■ **structure and principle of a cable winch**

Cable or hoist winches are machine elements that are classified as transmission or conversion elements. In a cable winch, a supporting cable is wound on a cable drum by means of a gear transmission. This allows loads secured to the supporting cable to be moved.

The TM 125 experimental unit is used to study the hoisting velocity and force transmission of a cable winch. It also demonstrates the function of a return stop. By considering equilibrium states, it is possible to determine force transmission and efficiency. The two cable drums are mounted on ball bearings. The forces are generated by weights and can be varied quickly and easily.

Laboratory and conceptual design from A–Z



Are you planning a new laboratory?

A new specialist room?

An entire department?

Do you want to modernize?

Then take advantage of our know-how and experience! Our engineers design complete laboratories and fit them out. We provide an individual response to your requirements, taking into account the specific local environment:

- room drawings
- supply connections
- equipment lists
- performance specifications, etc.

If you have any questions please contact our sales or customer service, who would be glad to help you.

TM 220

Belt drive and belt friction



Learning objectives/experiments

- effect of wrap angle, coefficient of friction and cable force (Eytelwein's belt friction formula)
- comparison of flat belts and V-belts
- consequences of an unadapted V-belt groove

Description

- function of a belt drive
- friction of different belt types on a metal pulley

The belt drives are machine elements that are classed as traction mechanisms in the field of transmission or conversion elements. They transfer torque and speed between guiding members such as wheels or pulleys. The motion is transferred by traction mechanisms that can only absorb tensile forces. Toothed belts and chains deliver positive transmission of movements. Traction mechanisms such as cables, flat belts and V-belts, on the contrary, allow for non-positive transmission.

In non-positive belt drives, the circumferential force between the belt and the pulley is transmitted according to the principle of cable friction.

Cable friction arises due to tangential static-friction forces at the points where the cable is in contact with the wheel or the pulley. Eytelwein's cable friction formula is used to calculate both cable and belt friction.

The TM 220 experimental unit allows the study by experiment of belt drives and belt friction. At the core of the experimental unit is a cast iron pulley, whose circumference features grooves for V-belts and flat belts. The pulley is mounted on ball bearings and is powered by a crank handle. Its flywheel mass favours an even rotation of the pulley. The belts rub on the pulley at a wrap angle between 30° and 180°. The wrap angle can be adjusted in increments of 15°.

Two spring balances detect the tensile forces on the respective belt ends. This makes it possible to precisely adjust the belt tension using a threaded spindle.

Two flat belts made of different materials, a V-belt and a cable belong to the scope of delivery. The experiments compare different belt types and materials and investigate the effect of the wrap angle.

In addition, for V-belts, it is possible to study how the groove shape affects the coefficient of friction.

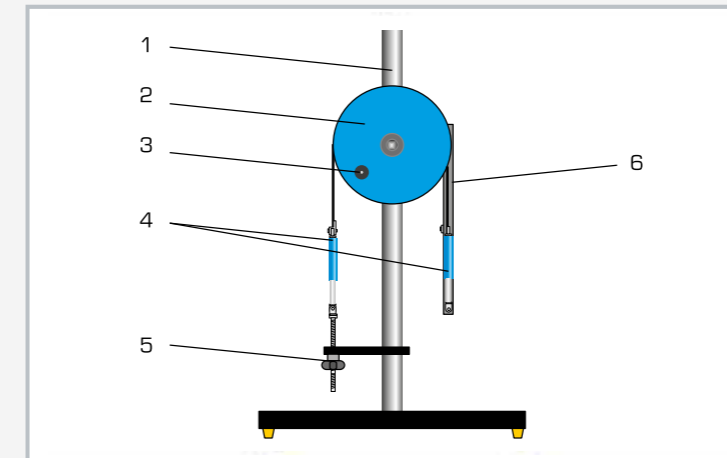

1 support column, 2 pulley, 3 crank handle, 4 spring balance, 5 belt tension adjustment, 6 pivoting belt holder

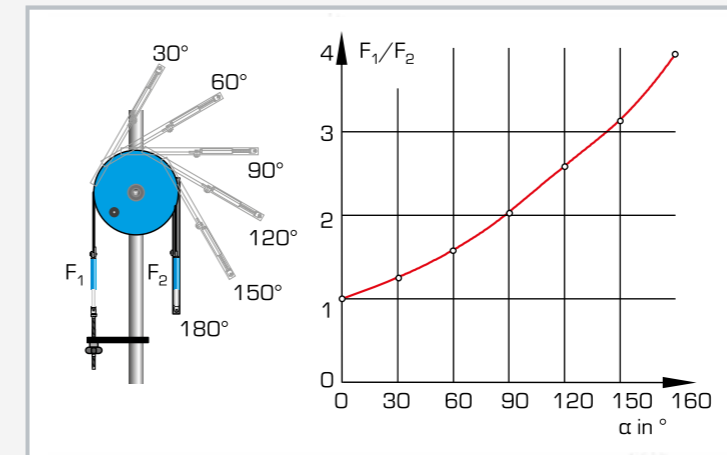

Gradual adjustment of the wrap angle from 30° to 180°. Diagram shows the force ratio F_1/F_2 as a function of the wrap angle α .

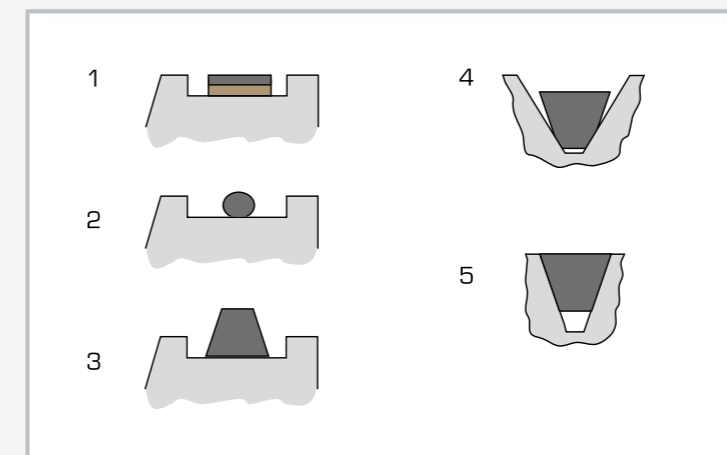

Comparison of different belt types: 1 flat belt, 2 cable, 3 V-belt, 4 adverse belt seat in the groove, 5 optimum belt seat in the groove

Specification

- [1] function of a belt drive
- [2] belt friction and comparison of different belt materials and types
- [3] ball-bearing mounted pulley with 3 different belt grooves
- [4] 2 flat belts made of different materials, 1 V-belt and 1 cable
- [5] wrap angle of the belts 30°...180°, graduation 15°
- [6] force measurement with 2 spring balances

Technical data

Flat belts

- 1x leather/polyamide, 15x2,2mm, Extremultus LT10
- 1x polyamide, 15x0,6mm, Extremultus TT2

V-belt

- ISO 4184
- profile: SPZ
- 9,7x8,0mm, rubber/fabric

Cable

- hemp, $\varnothing=3$ mm

Pulley

- $\varnothing=300$ mm
- material: grey iron
- Dynamometer: 100N ± 1 N

LxWxH: 700x350x1100mm
Weight: approx. 47kg

Scope of delivery

- 1 experimental unit
- 2 flat belts
- 1 cable
- 1 V-belt
- 2 dynamometers
- 1 set of instructional material

GL 410

Assembly simple gears

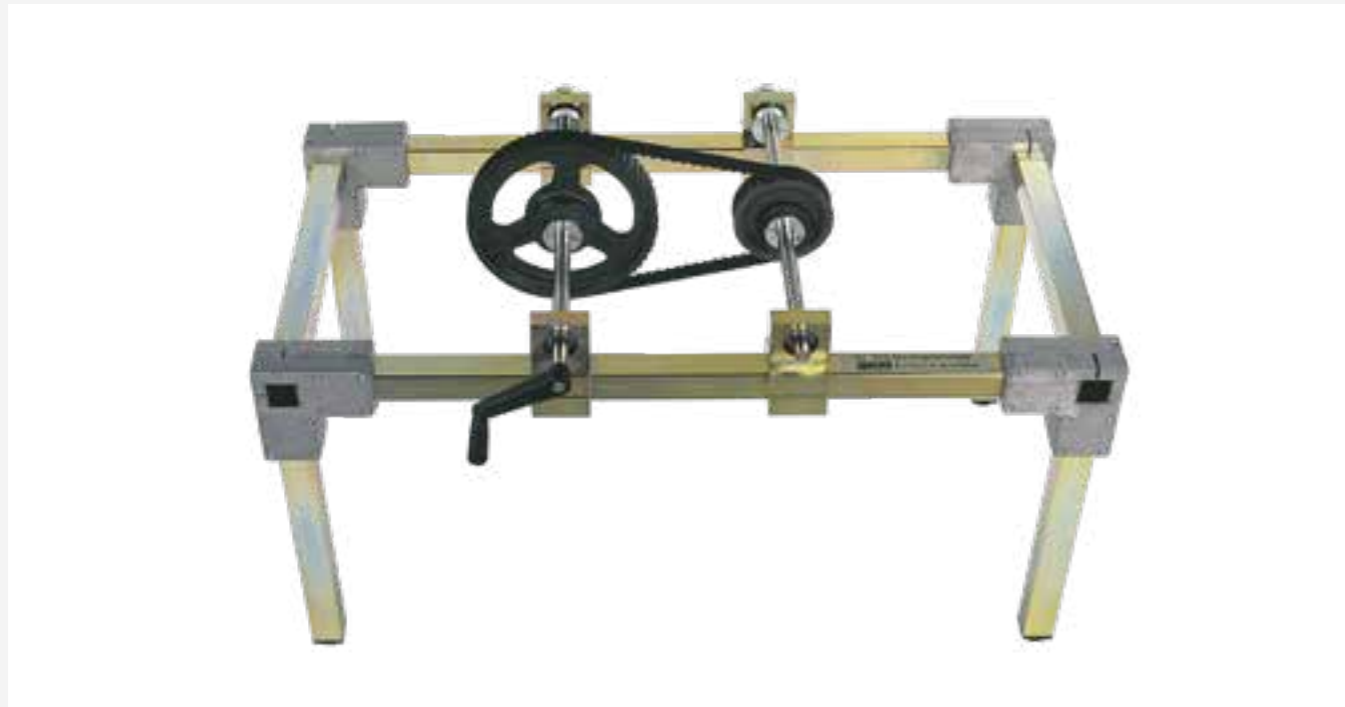

Description

- flexible and robust assembly kit for the fundamentals of mechanical gear engineering
- uses industrial components to represent the real world accurately
- quick and simple assembly

Gears are responsible for transferring the magnitude and/or direction of rotary motion and torque. In machine elements, gears are categorised as transmission or conversion elements. There are different types of gears depending on their task. Wheel gears such as gear drives, friction gears and traction gears are uniformly translating gears.

The GL 410 unit provides an introduction to the fundamentals of gear engineering. The unit focuses in particular on the practical assembly of gear components.

The exercise system can be used to configure six different, simple gear types. The setup of the components is flexible so that you can configure your own ideas and try out different gears.

Individual activities such as understanding the task and reading the drawing, assembling the components, adjusting, calibrating and checking the gear, and performing calculations are performed one after the other. The unit is driven by a hand crank. Various bearings and a solid frame made of square steel tubes ensures sufficient accuracy to be able to set precise tooth interlocking. All components of the exercise system are ready at hand and securely housed in a storage system.

GUNT offers three assembly kits in this product range: from simple gears (GL 410) to combined gears (GL 420) and control gears (GL 430). Each assembly kit can be used completely independently of the other parts in the range.

Learning objectives/experiments

- familiarisation with main components of mechanical gear engineering
- basic gear types
 - ▶ simple belt drive
 - ▶ simple chain gear
 - ▶ simple spur gear
 - ▶ bevel gear
 - ▶ worm gear
 - ▶ rack-and-pinion drive
- calculations on mechanical gears
- practical setup of different gears, associated with simple setup and configuration exercises
- read and understand engineering drawings, familiarisation with technical terms

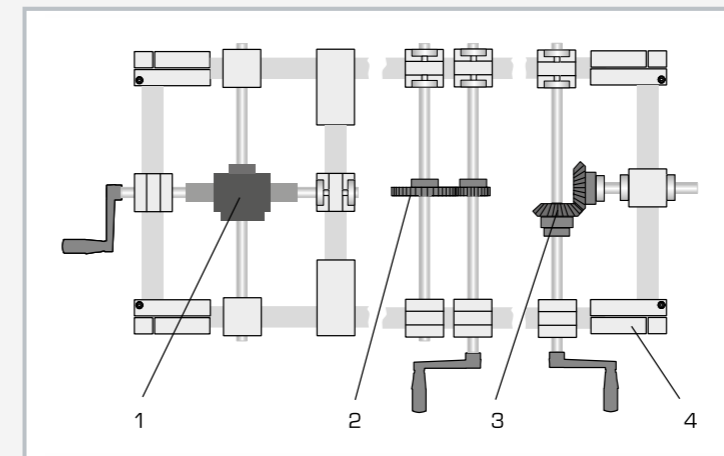

1 worm gear, 2 spur gear, 3 bevel gear, 4 square steel tube frame

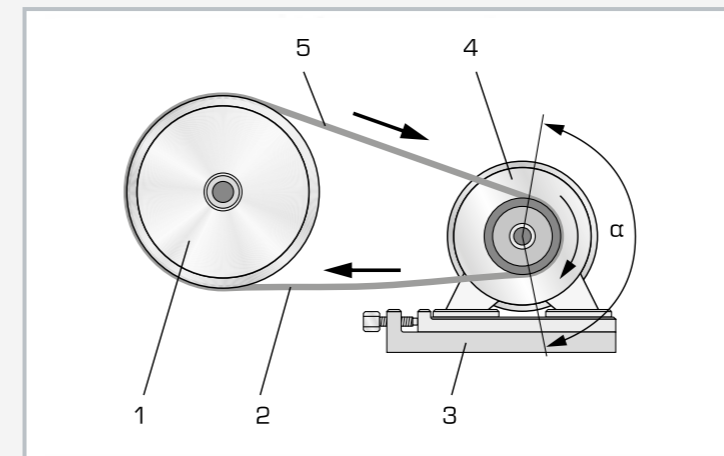

How a belt drive works: 1 driven pulley, 2 slack span, 3 tensioning rail with screws, 4 drive pulley, 5 tight span; α wrap angle

Specification

- [1] assembly, demonstration and experiments with simple gears
- [2] simple belt drive
- [3] simple chain gear
- [4] simple spur gear
- [5] bevel gear
- [6] worm gear
- [7] rack-and-pinion drive
- [8] driven by hand crank
- [9] uses industrial components
- [10] solid, universal frame made of square steel tube

Technical data

Toothed belt disk

- number of teeth: $z=30, 60$

Chain wheels

- number of teeth: $z=20, 30$
- DIN 8192 ISO 10B-1

Spur wheel

- number of teeth: $z=30, 60$
- module $m=2\text{mm}$

Pair of bevel gears

- number of teeth: $z=30$
- module: $m=3\text{mm}$
- transmission ratio: $i=1$
- angle of rotation: 90°

LxWxH: ca. 1030x500x520mm (assembled frame)

Weight: approx. 70kg

LxWxH: 600x400x220mm (storage system)

LxWxH: 600x400x170mm (storage system)

Scope of delivery

- 1 frame
- 1 set of bearings
- 1 set of gear components
- 1 set of tools
- 1 set of instructional material

GL 420

Assembly combined gears

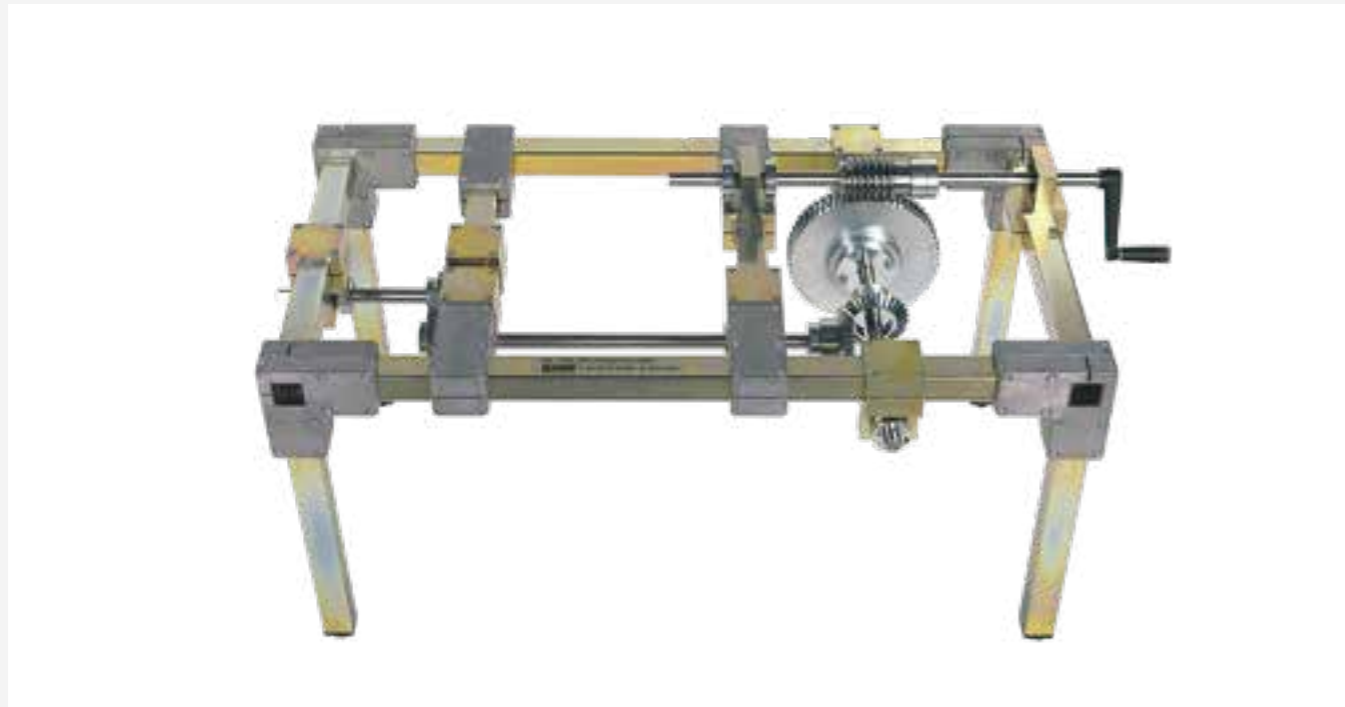

Description

- flexible and robust assembly kit for continuing mechanical gear engineering
- uses industrial components to represent the real world accurately
- quick and simple assembly

Different types of gear can be combined to achieve significantly altered transmission functions and new properties. The combination or interconnection can be done in series or in parallel. For example, several gear stages are often connected in series in order to achieve larger transmission ratios.

The GL 420 unit offers extensive exercises on the fundamentals of gear engineering. The unit focuses in particular on the practical assembly of gear components.

The exercise system can be used to configure six different gear types in various combinations. The setup of the components is flexible so that you can configure your own ideas and try out different gears.

Individual activities such as understanding the task and reading the drawing, assembling the components, adjusting, calibrating and checking the gear, and performing calculations are performed one after the other. The unit is driven by a hand crank. A solid frame made of square steel tubes and various bearings ensures sufficient accuracy to be able to set precise tooth interlocking. All components of the exercise system are ready at hand and securely housed in a storage system.

GUNT offers three assembly kits in this product range: from simple gears (GL 410) to combined gears (GL 420) and control gears (GL 430). Each assembly kit can be used completely independently of the other parts in the range.

Learning objectives/experiments

- familiarisation with main components and forms of mechanical gear engineering
 - ▶ two-stage belt drive
 - ▶ chain gear with tensioning wheel and spur gear ratio
 - ▶ two-stage spur gear
 - ▶ combined bevel and spur gears
 - ▶ combined worm and bevel gears
 - ▶ rack-and-pinion drive with spur gear
- calculations on mechanical gears
- practical setup of different gears, associated with setup and configuration exercises
- read and understand engineering drawings, familiarisation with technical terms

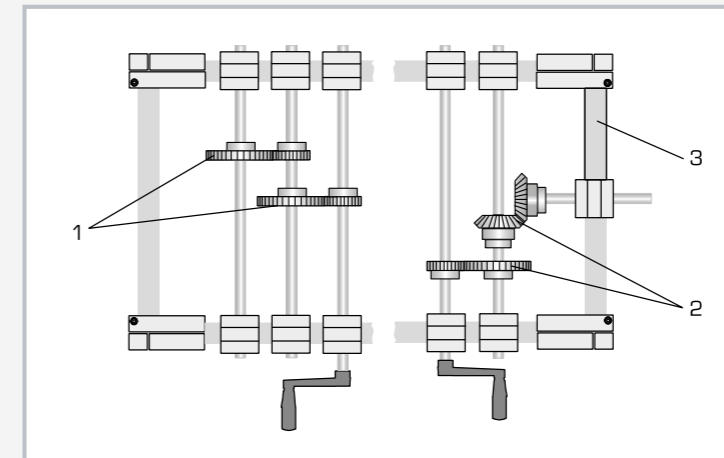

1 two-stage spur gear, 2 combined spur-bevel gear, 3 square steel tube frame

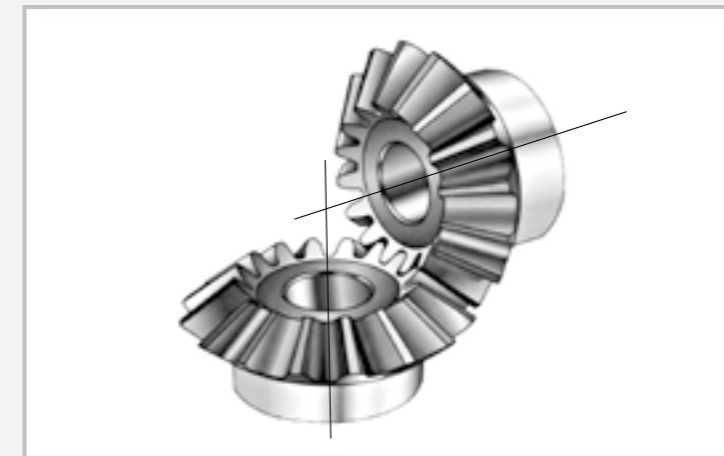

Bevel gear: drive and driven shaft at 90 degrees to each other. The outer form of the gear wheels (envelope) is equivalent to cones. The central axes intersect.

Specification

- [1] assembly, demonstration and experiments with combined gears
- [2] two-stage belt drive
- [3] chain gear with tensioning wheel and spur gear ratio
- [4] two-stage spur gear
- [5] combined bevel and spur gears
- [6] combined worm and bevel gears
- [7] rack-and-pinion drive with spur gear
- [8] driven by hand crank
- [9] uses industrial components
- [10] solid, universal frame made of square steel tube

Technical data

Toothed belt disk

- number of teeth: $z=30, 32, 48, 60$

Chain wheels

- number of teeth: $z=20, 30$
- DIN 8192 ISO 10B-1

Gear wheels

- number of teeth: $z=30, 36, 50, 60$
- module: $m=2\text{mm}$

Pair of bevel gears

- number of teeth: $z=30$
- module: $m=3\text{mm}$
- transmission ratio: $i=1$
- angle of rotation: 90°

LxWxH: 1000x500x500mm (assembled frame)

Weight: approx. 72kg

LxWxH: 600x400x120mm (storage system)

LxWxH: 600x400x170mm (storage system)

Scope of delivery

- 1 frame
- 1 set of bearings
- 1 set of gear components
- 1 set of tools
- 1 set of instructional material

GL 430

Assembly control gear

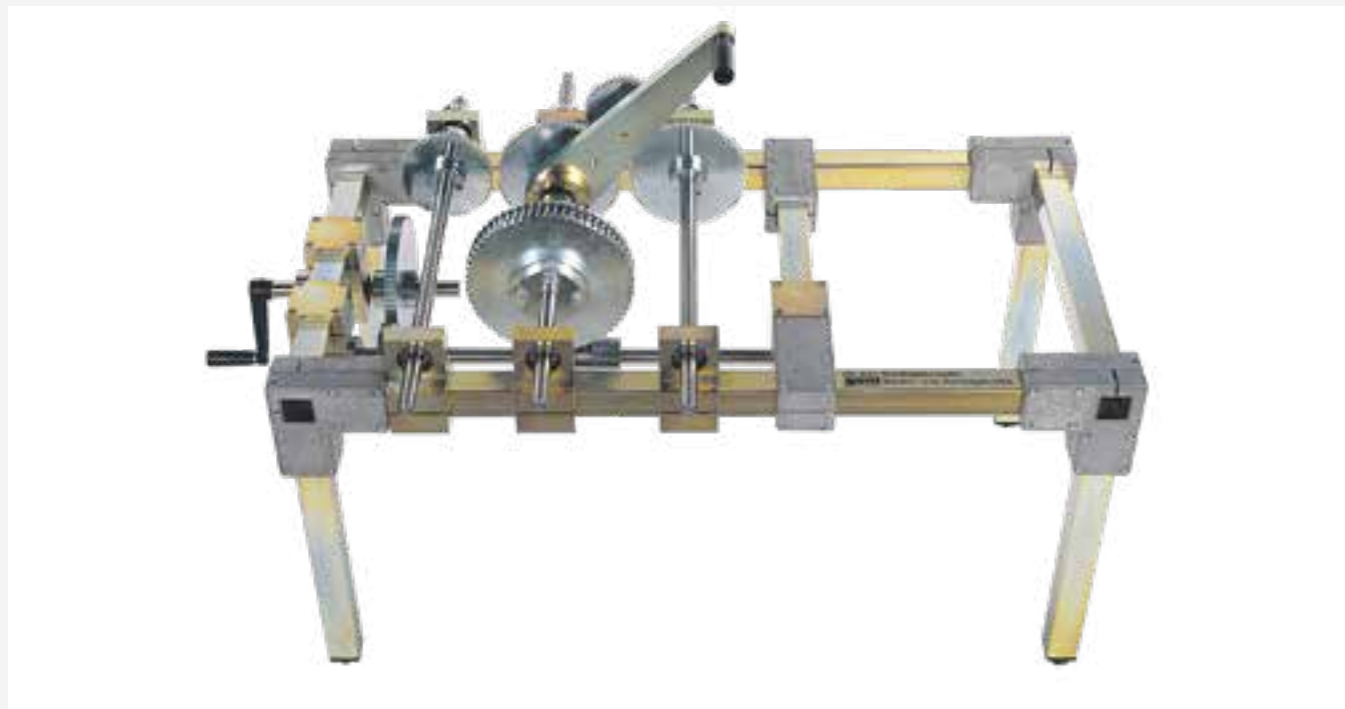

Description

- flexible and robust assembly kit for continuing mechanical gear engineering
- uses industrial components to represent the real world accurately
- quick and simple assembly

Control gears are also known as variable or change gears. They are characterised by the fact that the speed is transferred differently via various pairs of gear wheels. The most famous example is the transmission in a car, which has one pair of gear wheels for each "gear".

The GL 430 unit provides different configurations of control gears, which serve as an introduction to gear engineering. The unit focuses in particular on the practical assembly of gear components.

The exercise system can be used to configure six different gears in various combinations. The setup of the components is flexible so that you can configure your own ideas and try out different gears.

Individual activities such as understanding the task and reading the drawing, assembling the components, adjusting, calibrating and checking the gear, and performing calculations are performed one after the other. The unit is driven by a hand crank. A solid frame made of square steel tubes and various bearings ensures sufficient accuracy to be able to set precise tooth interlocking. All components of the exercise system are ready at hand and securely housed in a storage system.

GUNT offers three assembly kits in this product range: from simple gears (GL 410) to combined gears (GL 420) and control gears (GL 430). Each assembly kit can be used completely independently of the other parts in the range.

Learning objectives/experiments

- familiarisation with main components and forms of mechanical gear engineering
 - ▶ step pulley gear
 - ▶ sliding gear drive
 - ▶ Norton gear
 - ▶ tumbler gear
 - ▶ change gear
 - ▶ cam box (tripping device for lathe)
- calculations on mechanical gears
- practical setup of different gears, associated with setup and configuration exercises
- read and understand engineering drawings, familiarisation with technical terms

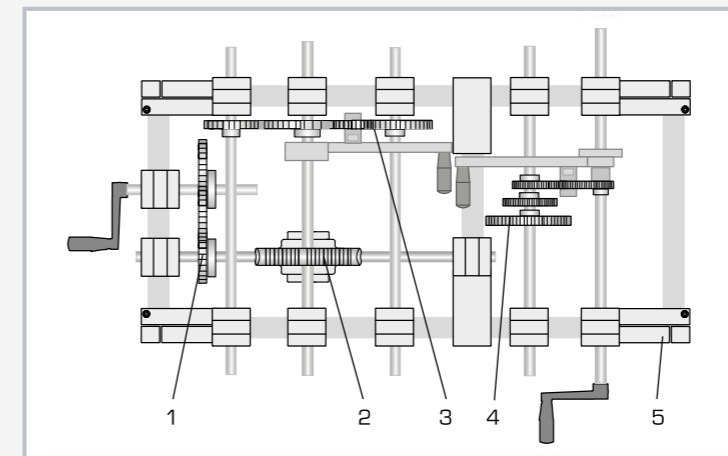

1 spur gear, 2 worm gear, 3 change gear, 4 Norton gear, 5 square steel tube frame

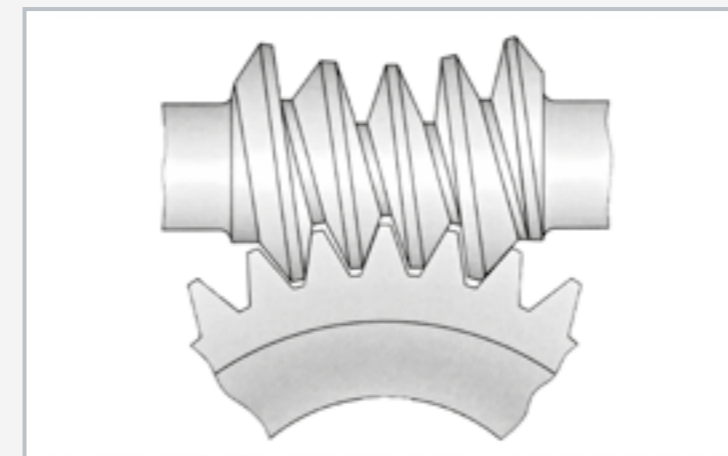

Worm gear

Specification

- [1] assembly, demonstration and experiments with different control gears
- [2] step pulley gear
- [3] sliding gear drive
- [4] Norton gear
- [5] tumbler gear
- [6] change gear
- [7] cam box (tripping device for lathe)
- [8] driven by hand crank
- [9] uses industrial components
- [10] solid, universal frame made of square steel tube

Technical data

Spur gears

- number of teeth: $z=24, 30, 36, 40, 45, 50, 60, 76, 80, 95$
- module: $m=2\text{mm}$

Worm gear

- worm
 - ▶ number of teeth: $z=6$
- worm wheel
 - ▶ number of teeth: $z=62$
 - ▶ module: $m=3,15\text{mm}$

LxWxH: 1000x500x500mm (assembled frame)

Weight: approx. 80kg

LxWxH: 600x400x120mm (storage system)

LxWxH: 600x400x170mm (storage system)

Scope of delivery

- 1 frame
- 1 set of bearings
- 1 set of gear components
- 1 set of tools
- 1 set of instructional material

GL 200
Lathe gear**Learning objectives/experiments**

- investigation of all essential gear functions of a lathe
- main gear
- change gear
- tumbler gear
- feed gear (Norton gear)

Specification

- [1] design and function of a lathe gear
- [2] fully functional experimental unit
- [3] optimum insight thanks to open design
- [4] shiftable main gear
- [5] Norton gear as feed gear to drive the lead screw
- [6] change gear and tumbler gear
- [7] record the feed on paper via recorder drum on the primary spindle driven by hand crank
- [8]

Technical data

Primary spindle speed stages: 9
Feed gear stages: 7

LxWxH: 750x500x800mm
Weight: approx. 42kg

Scope of delivery

- 1 lathe gear
- 1 set of instructional material

Description
■ safe and clear demonstration of the gear functions on a lathe

The GL 200 lathe gear has all the essential features and characteristics of a workshop lathe: a shiftable main gear, a feed gear for driving the lead screw (Norton gear), a change gear and a tumbler gear.

Drive is supplied by a hand crank with graduated dial. As such, the processes run slowly and completely safely.

The tool slide in this experimental unit performs only longitudinal motion. The automatic longitudinal feed is achieved by a lead screw. A removable recorder drum simulates the workpiece, while the cutting tool is replaced by a stylus.

Since the gear parts are exposed, all functions can be observed clearly. All experiments are easily repeatable and offer numerous variations.

First-rate handbooks



GUNT's policy is simple: high quality hardware and clearly developed accompanying instructional material ensure successful teaching and learning about an experimental unit.

The core of the accompanying material are detailed reference experiments that we have carried out. The description of the experiment contains the actual experimental setup right through to the interpretation of the results and findings. A group of experienced engineers develops and maintains the instructional material.

Nevertheless, we are here to help should any questions remain unanswered, either by phone or – if necessary – on site.

AT 200

Determination of gear efficiency



2E

Description

- mechanical efficiency of gears
- three-phase AC motor as the drive and magnetic particle brake as the brake unit
- comparison of worm and spur gears

The AT 200 unit is a complete test system with drive and brake unit and two different gears. Driving and braking power are calculated to determine the efficiencies. The components used are common in drive technology and therefore closely related to practice.

A three-phase AC motor with variable speed via frequency converter serves as the drive unit. An electromagnetic brake is used as the brake unit. The constant braking effect can be very finely adjusted via the exciting current; it then serves as a tunable load. The properties of the magnetic particle brake can be investigated in an additional experiment.

A two-stage spur gear and a worm gear are available to be studied. The characteristic properties of the gear are adapted to the performance of the motor. Flexible couplings connect the gear to the motor and the brake.

Motor and brake are mounted on pendulum bearings in order to determine the torques. The torques are measured by spring balance and lever arms. The speed of the motor is detected contact-free by means of an inductive displacement sensor on the motor shaft. The speed is displayed digitally. The exciting current of the magnetic particle brake is used as a measure of the braking torque and is also displayed.

Learning objectives/experiments

- determination of the mechanical efficiency of gears by comparing the mechanical driving and braking power for
 - ▶ spur gear, two-stage
 - ▶ worm gear
- plot the torque/current characteristic curve for a magnetic particle brake
- drive and control engineering

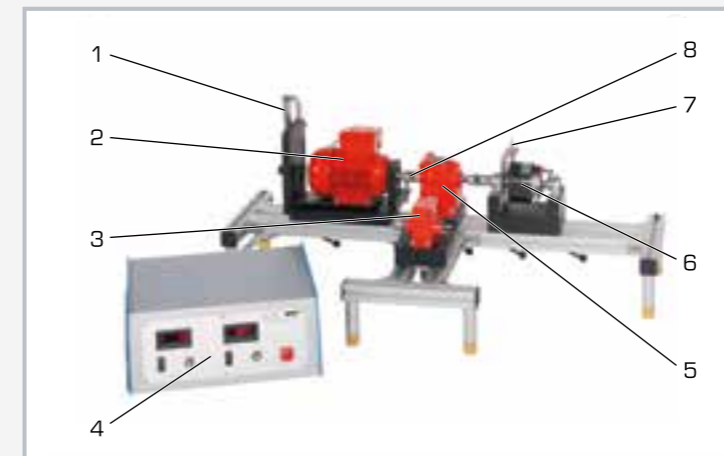

1 spring balance, 2 motor, 3 worm gear, 4 display and control unit, 5 spur gear, 6 brake, 7 brake lever arm, 8 coupling

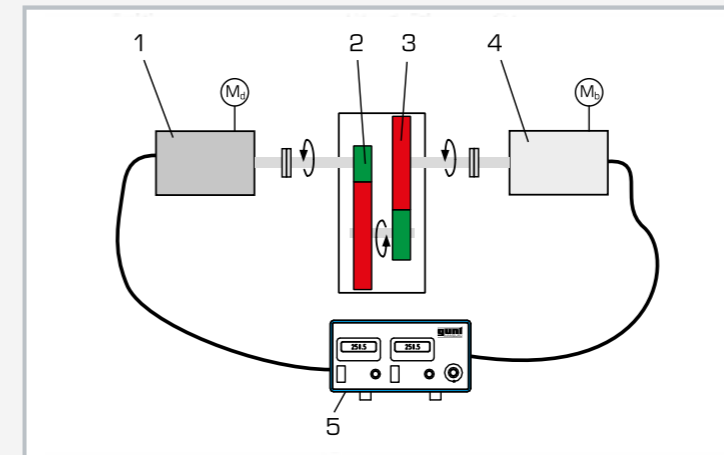

Determining the efficiency in the 2-stage spur gear: 1 motor, 2 first stage, 3 second stage, 4 brake, 5 display and control unit; M_1 drive torque, M_2 braking torque

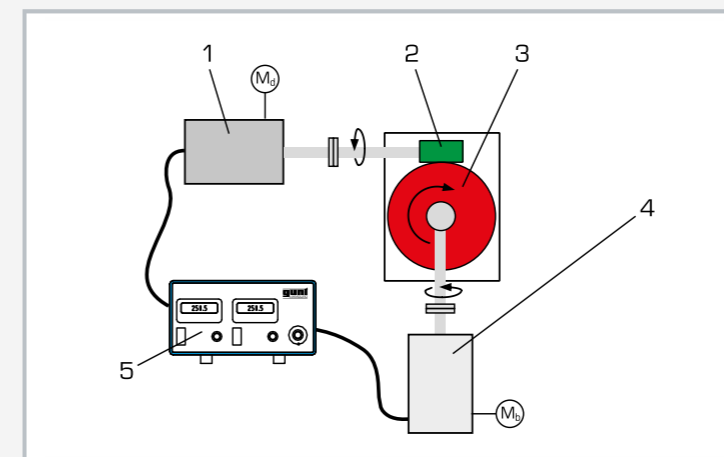

Determining the efficiency in the worm gear: 1 motor, 2 worm, 3 worm gear, 4 brake, 5 display and control unit; M_1 drive torque, M_2 braking torque

Specification

- [1] determination of mechanical efficiency in gears
- [2] investigation on worm gear and two-stage spur gear
- [3] three-phase AC motor with variable speed via frequency converter
- [4] magnetic particle brake with adjustable braking torque via exciting current
- [5] inductive speed sensor on the motor
- [6] display of speed and exciting current
- [7] determination of torques on motor and brake via spring balance and lever arms

Technical data

Three-phase AC motor with variable speed

- power output: 0,25kW
- speed: 0...3000min⁻¹

Magnetic particle brake

- rated braking torque at exciting current 0...0,37A: 0...10Nm

Two-stage spur gear

- transmission ratio: $i=13,5$
- torque: 23,4Nm

Worm gear

- transmission ratio: $i=15$
- torque: 10Nm
- worm: $z=2$
- worm gear: $z=40$

Measuring ranges

- speed: 0...3000min⁻¹
- current: 0...0,37A
- force: 0...100N

230V, 50Hz, 1 phase
230V, 60Hz, 1 phase; 120V, 60Hz, 1 phase
UL/CSA optional
LxWxH: 1060x600x420mm [experimental unit]
Weight: approx. 35kg
LxWxH: 420x450x180mm [display and control unit]
Weight: approx. 5kg

Scope of delivery

- 1 experimental unit
- 1 display and control unit
- 1 set of accessories
- 1 set of instructional material

Assembly exercises

Assembly process

In industrial manufacturing, the repeated fashioning of individual prefabricated components and assemblies into a finished product, unit or device is called assembly.

The entire assembly process comprises the assembly operations:



Joining (DIN 8593)

- joining together
- filling
- pressing on and impressing
- joining by moulding
- joining by forming
- welding
- soldering
- bonding
- textile joining



Handling (VDI 2860)

- retaining
 - ▶ changing quantities
 - ▶ dividing
 - ▶ merging
- moving
 - ▶ turning
 - ▶ positioning
- securing
 - ▶ holding
 - ▶ detaching
- inspecting
 - ▶ checking



Special operations

- cleaning
- aligning
- marking
- lubricating
- ...

Design based on assembly requirements

An optimum design based on assembly requirements is characterised by the fact that only a few simple, unique or essential steps are required to assemble a product. Similarly, a parallel assembly of components should be planned at the design stage. If fully automated assembly is planned, this requires sophisticated solutions especially for the automated, safe grasping

of the workpiece. In design based on assembly requirements, the prerequisites and constraints have to be taken into account when building the product in assembly. Design based on assembly cannot be learned by theoretical teaching, but must be practised.

Specifications for the design

Excerpt from the book, Grundlagen der Konstruktionslehre, Klaus-Jörg Conrad

When designing individual parts:

- design parts so that the ordering of the parts before assembly is not needed
- simplify position and orientation of the parts by external features, such as symmetrical shape
- simplify positioning by bevels, grooves, recesses, guides, etc.
- design joints so as to be easily accessible for tools and observation of the assembly process

When designing assemblies:

- structure product division with clear, testable assemblies in order to perform assembly operations with simple types of movement
- choose functional tolerances, but not too tight
- take note of disassembly and recycling in the design stage
- simplify or avoid calibration processes by means of good accessibility
- reduce number of individual components and joints
- design repetitive assemblies

Assembly exercises

The assembly exercises from GUNT are part of the GUNT-Practice Line. This series of units has been designed specifically for the areas of assembly, maintenance and repair (see also catalogue 2). Together with cutaway models, these units represent a practical addition to the field of engineering design. With our assembly exercises, we offer lecturers an interface between general, rather theoretical learning content and application-based, practical work.

Learning objectives

Develop broad knowledge of assembly technology as a basis for the design of assemblies

Introduction to technical terms and technical language

Familiarisation with machine elements and standard parts

Recognise assemblies, understand functions, describe systems

Read and understand technical documentation

Plan and execute assembly steps and sequences

Familiarisation with typical tools and devices

Check and evaluate work results



The typical scope of delivery of our assembly exercises is shown using the example of the MT 152 spur gear:

Spur gear deconstructed into individual parts, delivered in a solid metal case

Engineering drawing

Assembly plan

Extract from the documentation

Assembled spur gear

MT 170

Assembly shaft with journal bearings



The illustration shows the tool box with the kit and, in the foreground, the fully assembled journal bearing.

Description

- practical kit based on the assembly of a shaft / journal bearings arrangement
- part of the GUNT-Practice Line for assembly, maintenance and repair

Journal bearings execute a sliding motion between a bearing journal and a bearing shell. This sliding motion is usually lubricated by an intermediate medium. The damping effect of the lubricant in the bearing gap means journal bearings run particularly smoothly and quietly. Vibration and shock impact from gear wheels or crank mechanisms are also damped by journal bearings. They are widely used in piston engines, punches and presses as they are insensitive to high shock loads.

The MT 170 unit comprises a ground steel shaft and two horizontally split pedestal bearings. The journal bearings in MT 170 are grease-lubricated ones. Grease lubrication allows for a simple bearing construction. The upper bearing shell includes a lubrication fitting with a female thread to which a Stauffer lubricator can be screw-fitted by way of an intermediate pipe to supply the bearing with lubricant.

The face of the upper bearing shell, which is not subjected to load, contains a flat lubricating slot.

This distributes the grease over the full width of the bearing. The grease serves not only as a lubricant but also seals the bearing against external dirt and foreign bodies.

The MT 170 kit is part of the GUNT-Practice Line for assembly, maintenance and repair, which has been designed for technical colleges and company training centres. The close link between theory and practice-based learning content is evident.

MT 170 enables a simple journal bearing to be assembled and disassembled. Students become familiar with all the components and how they work. The individual parts are laid out clearly and are well protected in a tool box. The accompanying material details the individual steps involved in assembly, and provides additional information on the areas of application, mode of operation and design of the journal bearing.

Learning objectives/experiments

- function and design of a simple journal bearing
- assembly and disassembly, including for the purposes of maintenance and repair
- measure the bearing clearance
- check the alignment
- read and understand engineering drawings and operating instructions
- together with MT 172
 - ▶ investigate the running properties of the journal bearing

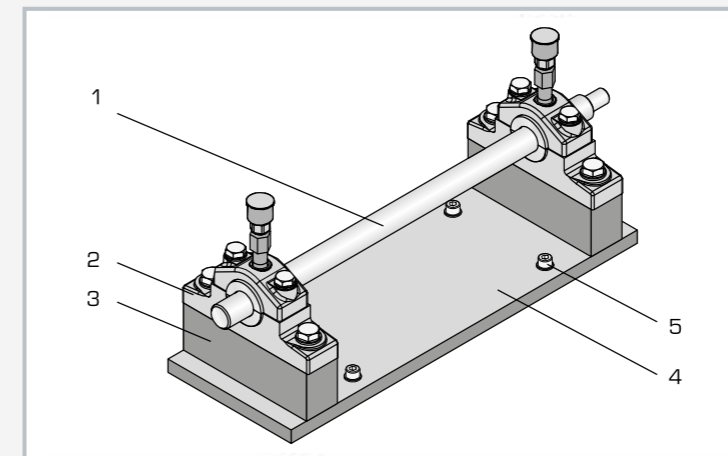

1 steel shaft, 2 pedestal bearing, 3 spacer, 4 base plate, 5 bolt to fix MT 170 into MT 172

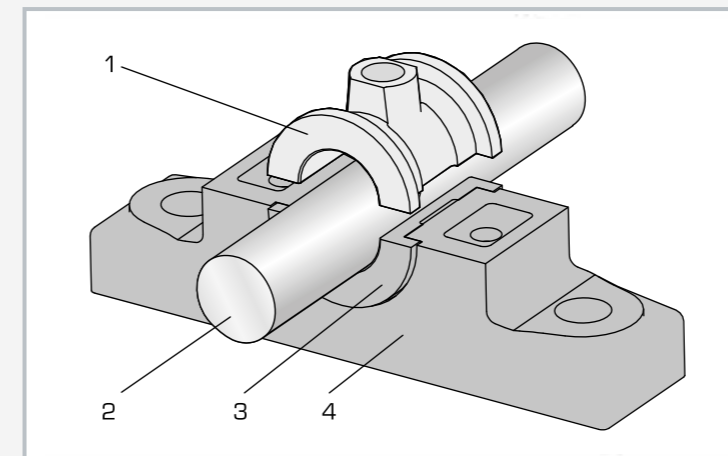

1 upper bearing shell, 2 shaft, 3 lower bearing shell, 4 bearing block

Specification

- [1] kit of a shaft with journal bearings
- [2] part of the GUNT-Practice Line for assembly, maintenance and repair
- [3] horizontally split pedestal bearing according to DIN 505, grease lubricated
- [4] steel shaft, hardened and ground
- [5] 2 pedestal bearings with split shells
- [6] set of plastic strips to measure bearing clearance
- [7] checking bearing alignment using touch-up paste
- [8] complete set of tools for assembly
- [9] journal bearing parts and tools housed in a sheet-steel tool box

Technical data

- Shaft
- Ø 25mm
 - shaft journal for coupling: Ø 16mm

Materials

- pedestal bearing, bearing cap: grey cast iron
- bearing shells: red bronze to DIN 8221
- shaft: hardened and ground steel
- Stauffer lubricator: steel

LxWxH: 640x230x230mm (tool box)
Weight: approx. 45kg

Scope of delivery

- 1 kit
- 1 metal bellows coupling for connection to MT 172
- 1 set of tools
- 1 set of small parts
- 1 1 tool box with foam inlay
- 1 set of instructional material

MT 171

Assembly hydrodynamic journal bearing



The illustration shows the tool box with kit and parts compartment insert. A fully assembled journal bearing is shown in the foreground.

Description

- practical kit of a hydrodynamic journal bearing
- part of the GUNT-Practice Line for assembly, maintenance and repair

Journal bearings generally execute a sliding motion between a bearing journal and a bearing shell. This sliding motion is usually lubricated by an intermediate medium. Hydrodynamic journal bearings give wear-free continuous duty for large diameters at high speeds, and are suitable for high and shock-type loading. They are usually constructed as split bearings. Frictional heat occurring during operation must be dissipated by the lubricant.

MT 171 is a horizontally split hydrodynamic pedestal journal bearing. The bearing shells are supported by a spherical face in the bearing housing so as to ensure uniform transfer of any forces that arise on the bottom part of the housing. The journal bearing is lubricated by a loose lubricating ring. Standard commercially available mineral oils can be used. An auxiliary shaft is supplied together with the bearing as an aid to assembly and functional testing.

The MT 171 kit is part of the GUNT-Practice Line for assembly, maintenance and repair, which has been designed for technical colleges and company training centres. The close link between theory and practice-based learning content is evident. MT 171 enables a hydrodynamic journal bearing to be assembled and disassembled. Students become familiar with all the components and how they work.

The individual parts are laid out clearly and are well protected in a tool box. The accompanying material details the individual steps involved in assembly, and provides additional information on the areas of application, mode of operation and design of the journal bearing.

Learning objectives/experiments

- function and design of a hydrodynamic journal bearing
- principles of lubrication and sealing elements
- assembly and disassembly, including for the purposes of maintenance and repair
- read and understand engineering drawings and operating instructions

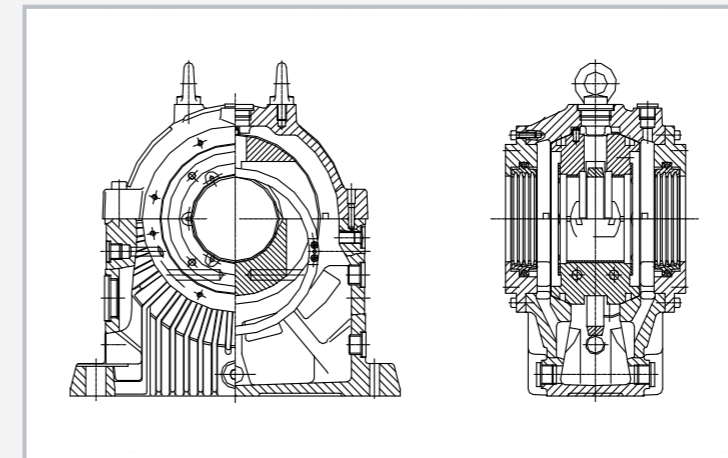

Sectional drawing of a hydrodynamic journal bearing

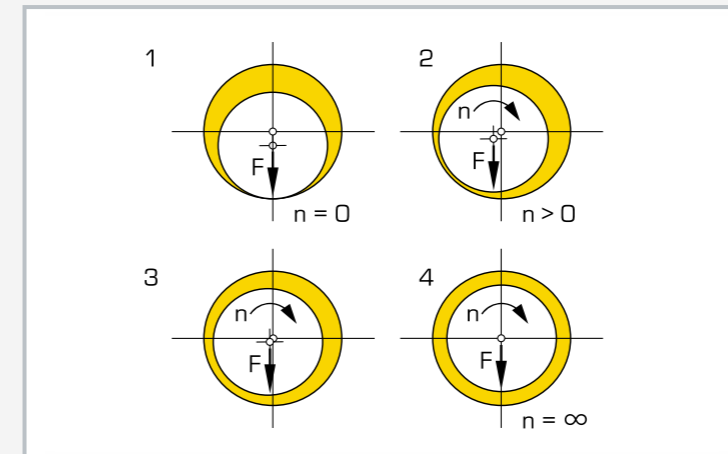

Operation of a hydrodynamic journal bearing: 1 to 4 build-up of a load-bearing oil film at increasing speed

Specification

- [1] kit of an upright hydrodynamic journal bearing
- [2] part of the GUNT-Practice Line for assembly, maintenance and repair
- [3] journal bearing to DIN 31690
- [4] stainless-steel drive shaft
- [5] lubrication via oil lubricating ring
- [6] floating edge seal to the face of the shaft seal
- [7] contact surfaces of the housing halves sealed with non-hardening sealant
- [8] complete set of tools for assembly
- [9] journal bearing parts and tools housed in a sheet-steel tool box

Technical data

Bearing bore
■ Ø 80mm

Drive shaft
■ nominal diameter: Ø 80mm

Materials

- bearing housing: grey cast iron
- bearing shells: steel supports, coated with white metal
- seal: ultra-heat-resistant, fibre-reinforced plastic
- shaft: stainless steel

LxWxH: 690x360x312mm (tool box)
Weight: approx. 60kg

Scope of delivery

- 1 kit
- 1 drive shaft
- 1 set of tools
- 1 set of small parts
- 1 tool box with foam inlay
- 1 set of instructional material

MT 152

Assembly spur gear



Learning objectives/experiments

- function and design of a helical spur gear unit
- planning and presentation of the assembly process
- assembly and disassembly, including for the purposes of maintenance and repair
- read and understand engineering drawings
- dimensioning exercises, gauging of parts
- familiarisation with various machine elements: ball bearings, shaft seals
- familiarisation with assembly aids and jigs
- material selection criteria

Description

- practical kit based on a spur gear unit
- broad scope of learning with interdisciplinary problems
- part of the GUNT-Practice Line for assembly, maintenance and repair

Gears transfer rotary motion. They adapt the torques and speeds of a consumer drive according to demand.

The MT 152 unit is a spur gear unit with helical gear wheels. The gear is single stage and has a fixed transmission ratio (fixed gear unit). It is a standalone gear unit, i.e. a self-contained transmission in its own gear housing. Self-contained gear units are usually arranged between the motor and the driven machine, or are used as installation kits in machines.

By contrast, open-running gear-wheel pairs forming part of a machine are termed non-self-contained gears.

Helically cut gear wheels run more smoothly and quietly than straight-toothed gears because the gear teeth intermesh gradually and multiple teeth are engaged. They are suitable for higher speeds, and can withstand greater loading than comparable straight-toothed gears.

The MT 152 kit is part of the GUNT-Practice Line for assembly, maintenance and repair, which has been designed for technical colleges and company training centres. The close link between theory and practice-based learning content is evident.

The assembly and disassembly processes can be completed easily within standard lesson times. Only basic tools are required for assembly, all of which are supplied with the kit. The fit seatings of the gear unit are designed to allow the complete assembly process to be performed by hand.

The unit is of most benefit in teaching if two or three students work together in a small group. The group has a defined task to perform, with clear assignments to complete.

The comprehensive instructional material focuses on practical needs. It includes a complete set of drawings with a general arrangement drawing, parts list and single-part drawings.



The illustration shows the assembled spur gear unit.

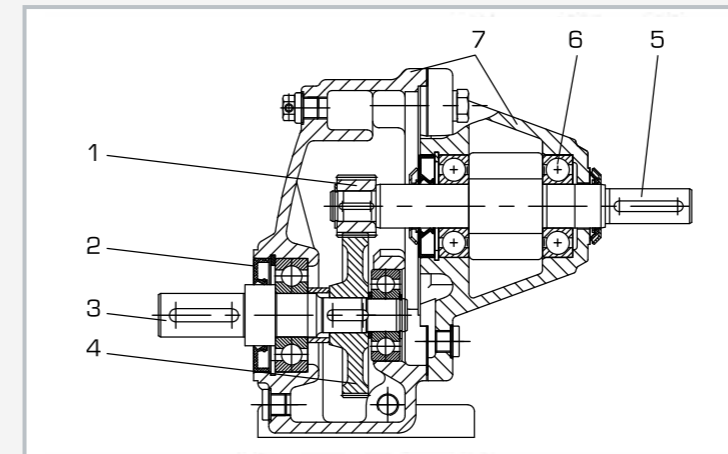

1 pinion, 2 shaft seal, 3 driven shaft, 4 gear wheel, 5 drive shaft, 6 ball bearings, 7 housing parts

Specification

- [1] kit of a spur gear unit
- [2] part of the GUNT-Practice Line for assembly, maintenance and repair
- [3] disassembled spur gear with set of small parts and 4 assembly jigs, housed in a sturdy case with foam insert
- [4] helical spur gear wheels
- [5] gear unit comprising input housing, pedestal housing, input and output shafts, input gear and output pinion, as well as bearings

Technical data

Gear dimensions without shaft connections
 ■ LxWxH: 160x135x175mm

Transmission ratio

- pinion
 - ▶ number of teeth: $z=24$
 - ▶ real pitch module: $m=1$ mm
- gear wheel
 - ▶ number of teeth: $z=68$
 - ▶ real pitch module: $m=1$ mm
- transmission ratio: $i=2,83$

Max. drive torque
 ■ 54Nm at 494min⁻¹

Materials

- housing: cast iron
- shafts: tempered steel
- spur wheels: alloyed case-hardened steel

Shaft connections

- drive: $\varnothing \times L$: 16x40mm
- driven: $\varnothing \times L$: 20x40mm

LxWxH: 600x450x180mm (case)

Weight: approx. 18kg

Scope of delivery

- 1 kit
- 1 set of tools
- 1 set of assembly jigs
- 1 set of small parts
- 1 case
- 1 set of instructional material with complete set of drawings with individual parts and parts list

MT 110.02**Assembly spur wheel / worm gear mechanism**

The illustration shows the tool box with the kit. The compartment insert for tools and small parts is shown in the foreground.

Description

- practical assembly of an industrial gear unit, using simple tools and devices
- broad scope of learning with interdisciplinary problems
- part of the GUNT-Practice Line for assembly, maintenance and repair

The MT 110.02 unit deals with a two-stage gear. The kit contains all the individual parts to build the gear. The gear comprises a spur gear stage as its input, with a downstream worm gear stage (combined gear). The fit seatings of the gear unit are designed to allow the complete assembly process to be performed by hand. All parts are laid out clearly and are well protected in a sheet-steel tool box. Small parts are contained in a box with a transparent lid. A set of tools is included.

The project-based nature of this assembly kit allows for varied and above all interdisciplinary work in the classroom. The project is particularly recommended for a practical-based teaching organisation, in conjunction with independent student activity and teamwork.

The contemporary instructional materials provide extensive technical information that provides the basis for lesson design. The core element of the teaching materials is a complete set of drawings with lists of parts, individual part designations, exploded views and assembly drawings. All drawings are to standard and are dimensioned in accordance with production requirements. Pdf files and assembly videos are also useful features.

The fully assembled gear can be tested for functionality using the optionally available MT 172.

Learning objectives/experiments

- function and design of a combined gear unit
- reading and understanding engineering drawings
- familiarisation with components and assemblies, their design features and functions
- dimensioning exercises, gauging of parts
- work planning, in particular planning and representation of the assembly process
- familiarisation with assembly aids and jigs
- assembly exercises: assembly of modules and complete units
- analysis of faults and damage, in conjunction with maintenance and repair steps
- material selection criteria
- in conjunction with MT 172
 - ▶ functional testing of the assembled gear unit



The illustration shows the assembled gear unit.

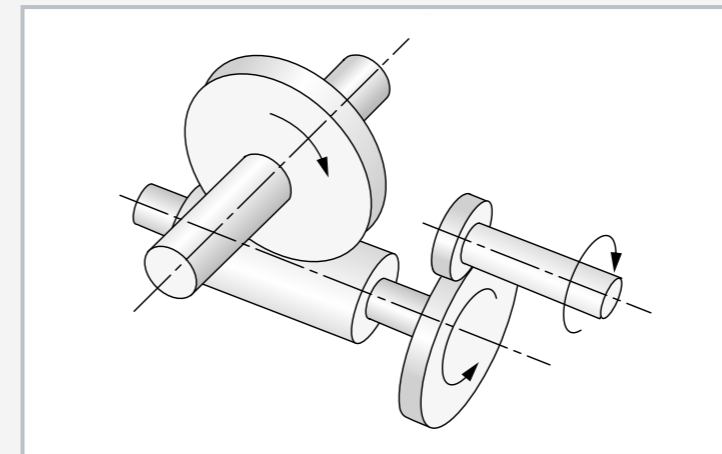

Drive principle of the two-stage spur wheel / worm gear mechanism

Specification

- [1] kit of a spur wheel / worm gear mechanism
- [2] part of the GUNT-Practice Line for assembly, maintenance and repair
- [3] complete, disassembled gear unit with set of small parts and 12 assembly jigs in a storage box
- [4] spur gear stage with helical gear wheels
- [5] worm gear stage with cylindrical worm and globoid wheel
- [6] gear unit comprising drive housing, worm pedestal housing, driving and driven shafts, spur gear stage and worm gear stage

Technical data

Gear dimensions without shaft couplings

- LxWxH: 282x138x188mm, approx. 22kg

Transmission ratios

- spur gear stage: $i=2,83$
- worm gear stage: $i=12,33$
- total gear ratio: $i=34,89$

Spur gear stage

- pinion: number of teeth: $z=24$, real pitch module: $m=1\text{mm}$
- gear wheel: $z=68$, $m=1\text{mm}$

Worm gear stage

- worm: $z=3$
- worm gear wheel: $z=37$, $m=2,578\text{mm}$

Max. output torque: 212Nm

Materials

- housing: cast iron
- shafts: tempered steel
- spur gear wheels, worm: alloyed case-hardened steel

Shaft connections

- drive: $\varnothing \times L$: 16x40mm
- driven: $\varnothing \times L$: 30x60mm

LxWxH: 700x380x320mm (tool box)

Weight: approx. 38kg

Scope of delivery

- 1 kit
- 1 set of tools
- 1 set of assembly jigs
- 1 set of small parts
- 1 set of gaskets
- 1 tool box with foam inlay
- 1 set of instructional material, consisting of technical description of system, complete set of drawings with individual parts and parts list, description of assembly and disassembly sequences, pdf files, assembly videos

MT 172**Alignment of drives, shafts and gears**

2E

The illustration shows MT 172 together with a combination gear unit assembled from the kit MT 110.02.

Description

- **assembly and alignment of drive elements**
- **understanding a wide range of mechanical drive systems**
- **functional testing of completed GUNT assembly kits**

The MT 172 unit is used to perform functional tests on MT 170 (shaft with journal bearings), MT 110 and MT 110.02 (combination gear units). The assembled element system – journal bearing or gear unit – is mounted on the MT 172 test bed. Here, the complete system is properly assembled, with particular regard to the alignment of the system components. A successfully completed assembly project can then be examined in operation with a formal final test. Parameters examined during test procedure are running noise, heat generation, vibrations or leakage.

MT 172 includes a single-phase asynchronous motor drive, a magnetic particle brake with adjustable braking torque, and a rigid machine bed with T-slots on which the motor and the drive element under test are mounted.

The T-slots allow the installed length to be varied, and therefore can be easily adapted to the drive element. Two couplings connect the element system to the motor and the brake. The students must align the connections between the motor and the element system, and between the element system and the brake. The controls are located on the switch box.

The braking torque is set here using a potentiometer. The exciter current of the magnetic particle brake serves as a measure of the braking torque, and is displayed in digital form. Removable guards protect the couplings.

The MT 172 unit is part of the GUNT-Practice Line for assembly, maintenance and repair, which has been designed for technical colleges and company training centres.

Learning objectives/experiments

- in conjunction with MT 170 and MT 110.02
 - ▶ assembly and alignment of gears or shafts with journal bearings
 - ▶ planning and execution of final testing on a helical worm gear (MT 110.02)
 - ▶ planning and execution of final testing on a journal-bearing-mounted shaft (MT 170)
 - ▶ familiarisation with gear components and their functions
- in conjunction with combined gear unit MT 110.02
 - ▶ checking gear functionality after assembly using a load test
 - ▶ running of the gear under variable load: assessment of running noise; checking for heat build-up; checking for leaks
- in conjunction with MT 170 shaft with journal bearings
 - ▶ running properties of a journal bearing

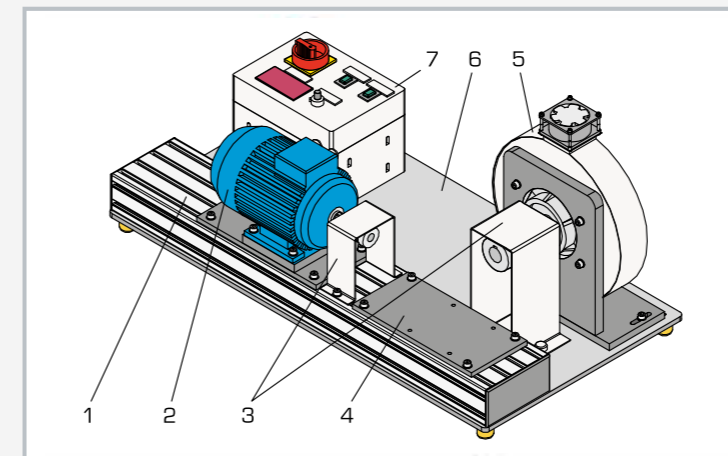

1 machine bed, 2 drive motor, 3 coupling guard, 4 combination gear unit mounting plate, 5 magnetic particle brake, 6 base plate with flexible elements for vibration damping, 7 switch box with displays and controls



The illustration shows MT 172 together with the journal bearing-mounted shaft MT 170.

Specification

- [1] experimental unit for functional testing of mechanical gear units: shaft on journal bearing, combined gear unit
- [2] part of the GUNT-Practice Line for assembly, maintenance and repair
- [3] single-phase asynchronous motor with metal bellows coupling
- [4] externally vented magnetic particle brake with claw clutch, braking power adjustable by potentiometer
- [5] machine-bed T-slot aluminium profile for adjustable mounting of gear components
- [6] switch box with controls and digital display of exciter current of the magnetic particle brake
- [7] coupling guards

Technical data**Drive motor**

- 4-pole asynchronous motor
- max. power: 0,55kW
- speed: 1400min⁻¹

Magnetic particle brake with fan and temperature sensor

- nominal braking torque at exciter current 0...0,4A
 - ▶ 0...45Nm
- max. braking torque at 1A: 110Nm
- bi-metallic strip temperature protection: 70°C

Aluminium machine bed with T-slots

- installation space: LxW: 640x160mm
- slot spacing: 40mm
- for M8 sliding blocks

230V, 50Hz, 1 phase
120V, 60Hz, 1 phase; 230V, 60Hz, 1 phase
UL/CSA optional
LxWxH: 950x500x450mm
Weight: approx. 75kg

Scope of delivery

- 1 experimental unit
- 1 set of small parts
- 1 set of tools
- 1 set of instructional material

MT 190

Assembly materials tester



Description

- kit of a unit for basic experiments in materials testing
- can be expanded with electronic data acquisition
- part of the GUNT-Practice Line for assembly, maintenance and repair

The MT 190 unit is supplied as a kit and contains all mechanical parts, measuring units, hydraulic components with seals and pipe material with all connecting parts. Assembly comprises the mechanical structure, the hydraulic assembly of both cylinders and the piping installation. All tools and aids required are included, as well as extensive teaching materials.

The MT 190.01 assembly set allows for data acquisition as an extension to the range of experiments. Using MT 190, students can learn about working on a complex project. This involves the planning, implementation and checking of processes related to assembly, commissioning and repair.

The assembled MT 190 experimental unit represents a real, fully functional materials tester that can be used to conduct tensile tests and Brinell hardness tests. The experimental unit has been developed specifically for experiments in small groups and is characterised by a clear design, simple operation and accessories that are easy to exchange.

The tensile specimens are clamped between the upper cross member and the crosshead. The hardness specimens are secured between the crosshead and lower cross member. The test force is generated by means of a hand-operated hydraulic system and displayed on a large force gauge with a drag indicator. A dial gauge measures the elongation of the specimens.

Learning objectives/experiments

- read and understand technical documentation
- plan and execute assembly steps and sequences
- familiarisation with machine elements and components
- commission and inspect materials tester after successful assembly
- plan, implement and evaluate maintenance operations
- fault analysis: troubleshooting, fault analysis and remedy
- after successful assembly
 - ▶ tensile test on metallic specimens
 - ▶ plot load-extension diagrams
 - ▶ Brinell hardness test

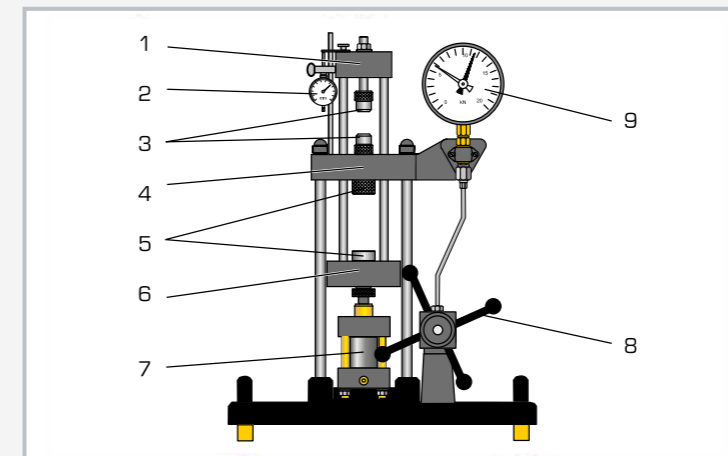

1 upper cross-member, 2 dial gauge for elongation, 3 clamp, 4 crosshead, 5 compression piece and pressure plate, 6 lower cross-member, 7 hydraulic cylinder, 8 hand wheel, 9 force gauge

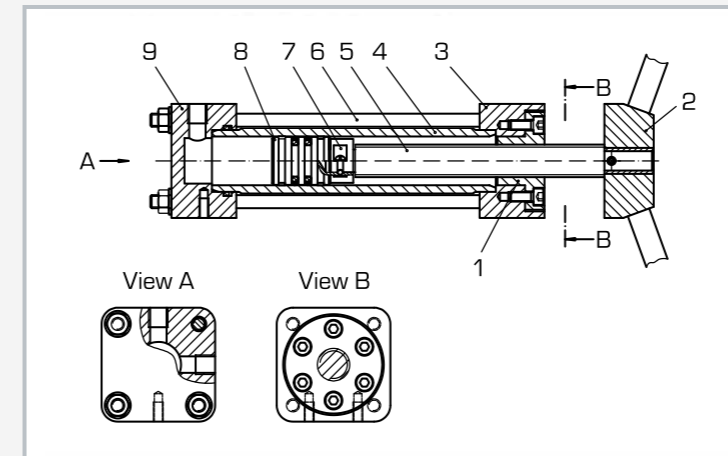

Sectional drawing of the horizontal hydraulic cylinder: 1 trapezoidal nut, 2 hand wheel axle, 3 crank side flange, 4 cylindrical tube, 5 trapezoidal threaded spindle, 6 clamping bolt, 7 retainer, 8 piston, small, 9 pressure side flange

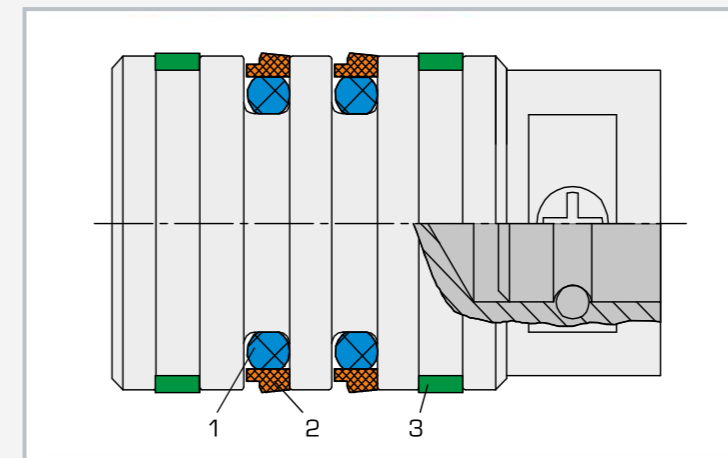

Piston in detail: 1 O-ring, 2 piston sealing ring, 3 guide ring

Specification

- [1] assembly kit of a materials tester
- [2] part of the GUNT-Practice Line for assembly, maintenance and repair
- [3] hydraulic assembly of two cylinders
- [4] pipework assembly of the hydraulic system
- [5] classic destructive tests from the field of materials testing: tensile tests, Brinell hardness test
- [6] generation of tensile and compressive forces
- [7] forces generated by hand-operated hydraulic system; no power supply required
- [8] force gauge, pointer instrument with drag indicator
- [9] dial gauge for determining the elongation
- [10] hardness specimens: aluminium, copper, steel, brass
- [11] tensile specimens according to DIN 50125: aluminium, copper, steel, brass
- [12] assembly kit for MT 190.01 data acquisition available as an option

Technical data

Test force: max. 20kN
 Stroke: max. 45mm
 Free installation space for specimens: 165x65mm
 Tensile specimens: B6x30mm, DIN 50125
 Hardness specimens: LxWxH 30x30x10mm
 Sphere for hardness testing: \varnothing 10mm

Measuring ranges

- force: 0...20kN, graduation: 0,5kN
- travel: 0...10mm, graduation: 0,01mm

LxWxH: 610x520x850mm (assembled)
 Weight: approx. 53kg

Scope of delivery

- 1 kit
- 1 set of tools
- 1 set of assembly jigs
- 1 set of small parts
- 1 set of accessories
- 1 set of specimens (4 tensile specimens, 4 hardness specimens)
- 1 set of instructional material, consisting of: technical description of system, complete set of drawings with individual parts and parts list, description of maintenance and repair processes, suggested exercises

MT 190.01**Assembly data acquisition for materials tester****Description**

- interdisciplinary and interlinking kit from the fields of mechanics and electronics
- fully functional data acquisition system for a materials tester with USB connection and software

The MT 190.01 unit is supplied as a kit and contains all components and materials to build a professional data acquisition system. Assembly comprises the mechanical structure and the wiring according to the circuit diagram. All tools and aids required are included, as well as extensive teaching materials.

The assembled MT 190.01 system represents a real, fully functional data acquisition system and can be used to measure pressure (forces) and changes in length.

These values are processed further on a PC by means of analysis software. The data acquisition system enhances the options of the MT 190 project considerably. Both projects together give a modern materials tester with data acquisition, which is suitable for a variety of experiments.

Using MT 190.01 students can learn about working on a complex project. This involves the planning, implementation and checking of processes related to assembly, commissioning and repair.

Learning objectives/experiments

- fundamentals of data acquisition: familiarisation with sensors, electronics for recording and outputting measured values, interfaces, software
- read and understand technical documentation
- plan and execute assembly steps and sequences
- commissioning and inspection of a data acquisition system following assembly
- system integration: connect materials tester and data acquisition
- together with MT 190
 - ▶ record load-extension diagrams or stress-strain diagrams
 - ▶ prepare, display and store data
 - ▶ output diagrams to printer

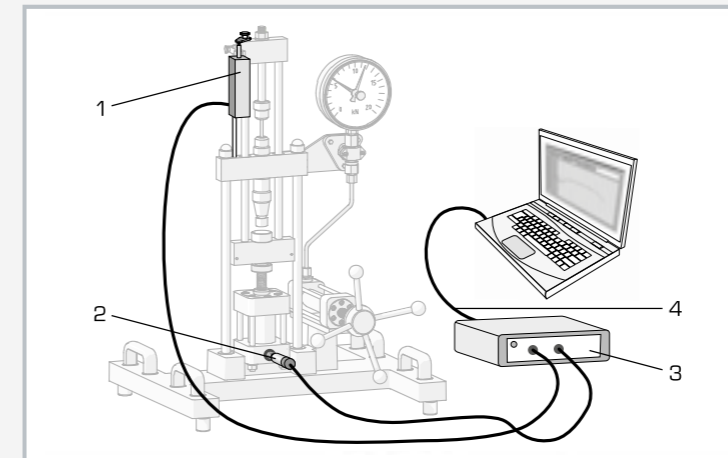

Port for connecting data acquisition to the basic unit: 1 displacement sensor, 2 pressure sensor for force measurement, 3 measuring amplifier, 4 USB cable



Assembled data acquisition system with software CD; in the foreground: left: pressure sensor, right: displacement sensor

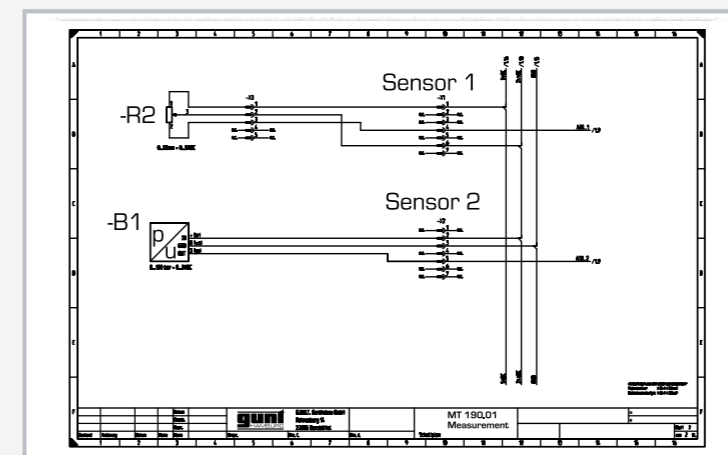

Circuit diagram: port for pressure and displacement sensor

Specification

- [1] kit for assembly of a data acquisition system for a materials tester
- [2] part of the GUNT-Practice Line for assembly, maintenance and repair
- [3] linear potentiometer for displacement measurement
- [4] force measurement by pressure sensor
- [5] GUNT software for data acquisition via USB under Windows 7, 8.1, 10
- [6] software for recording, preparing and storing stress-strain diagrams

Technical data

Pressure sensor for force measurement
 ■ 0...100bar

Displacement sensor
 ■ 0...50mm

Measuring amplifier with USB port
 ■ input: 0...5V
 ■ resolution: 12bit

230V, 50Hz, 1 phase
 120V, 60Hz, 1 phase; 230V, 60Hz, 1 phase
 UL/CSA optional
 LxWxH: 225x200x75mm (measuring amplifier)
 Weight: approx. 5kg

Required for operation

PC with Windows

Scope of delivery

- 1 kit
- 1 set of tools
- 1 set of accessories
- 1 GUNT software CD + USB cable
- 1 set of instructional material, consisting of: technical description of system, complete set of drawings with individual parts and parts list, circuit diagram, description of maintenance and repair processes, suggested exercises

Materials testing

Introduction	
Overview Mechanical testing methods	316
Overview Course Fundamentals of materials testing	326

Tensile, compression, bending and hardness testing	
WP 300 Materials testing, 20 kN	332
WP 310 Materials testing, 50 kN	334
SE 100 Frame for load testing, 400 kN	336
SE 110.48 Bending test, plastic deformation	338

Impact test	
WP 400 Impact test, 25 Nm	340
WP 410 Impact test, 300 Nm	342

Torsion test	
WP 500 Torsion test, 30 Nm	344
WP 510 Torsion test 200 Nm, motor drive	346

Fatigue of materials	
WP 140 Fatigue strength test	348
WP 600 Creep rupture test	350

Tribology and corrosion	
Overview Tribology and corrosion	352
TM 260 Drive unit for tribological investigations	354
TM 260.01 Rolling friction in friction wheels	356
TM 260.02 Elasto-hydrodynamic behaviour	358
TM 260.03 Dynamic friction in pin – disk	360
TM 260.04 Frictional vibrations	362
TM 260.05 Dynamic friction in cylindrical pin – roller	364
TM 260.06 Pressure distribution in journal bearings	366
TM 232 Bearing friction	368
TM 282 Friction in journal bearings	370
TM 280 Pressure distribution in journal bearings	372
TM 290 Journal bearing with hydrodynamic lubrication	374
CE 105 Corrosion of metals	376

Mechanical testing methods

Materials testing studies the behaviour of materials under different loads. In particular, the relationship between the acting forces and the resulting deformation and the limit stresses that lead to failure of components are considered.

The characteristic values obtained from the testing process are used for materials development, designing components and

in quality assurance. There is a range of standardised testing methods to characterise the mechanical properties of materials as precisely as possible:

Mechanical property	Testing method
Elasticity, plasticity	Tensile test, compression test, bending test, torsion test
Material behaviour under static load	
Creep behaviour	Creep rupture test
Hardness	Brinell, Rockwell, Vickers
Toughness	Impact test
Fatigue behaviour, fatigue strength	Wöhler fatigue test

The fracture behaviour is used to characterise the material.

The summary below shows a relationship between failure mechanism and stress:

Fracture type	Fracture mechanism	Stress
Forced fracture <ul style="list-style-type: none"> occurs abruptly matte or glossy crystalline and partially fissured surface over the entire cross section; in ductile fractures, shear lips often occur at the edge 	Static overstress <ol style="list-style-type: none"> low-deformation cleavage fracture occurs when the largest direct stress exceeds the cleavage fracture stress ductile fracture (microscopic honeycomb fracture) occurs when the largest shear stress exceeds the yield stress a low-deformation intergranular fracture can occur with a reduction of the grain boundary cohesion under the influence of direct stress 	Tensile test, impact test
Fatigue fracture <ul style="list-style-type: none"> can develop following repeated stress under the influence of shear or direct stress low-deformation fracture 	Dynamic overstress Starting from notches or imperfections, oscillatory cracks propagate through the material. When the material strength is exceeded, the remaining surface fractures by way of a forced fracture.	Wöhler fatigue test
Creep fracture <ul style="list-style-type: none"> continuous time-dependent process sets in at higher temperatures and eventually leads to fracture, although the material is loaded below the hot yield point pores on grain boundaries lead to material damage 	Static stress, e.g. increased temperature Countless cracks form independently of each other	Creep rupture test

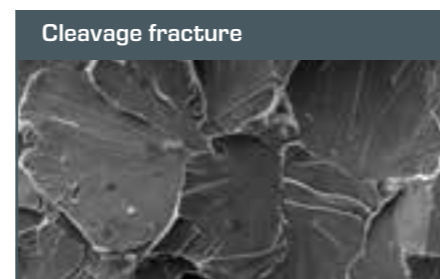
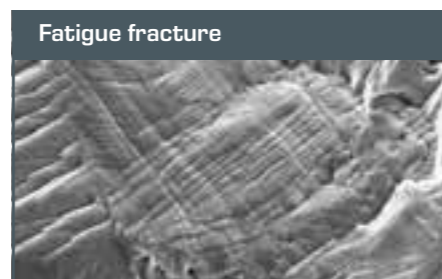
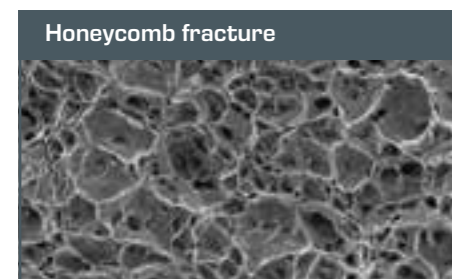

Tensile test to determine the tensile strength and elongation at fracture

The tensile test is the most important testing method in destructive materials testing. A standardised specimen with a known cross section is loaded uniformly with relatively low increasing force in the longitudinal direction. A uniaxial stress

state prevails in the specimen until contraction commences. The ratio of stress to strain can be shown from the plotted load-extension diagram.

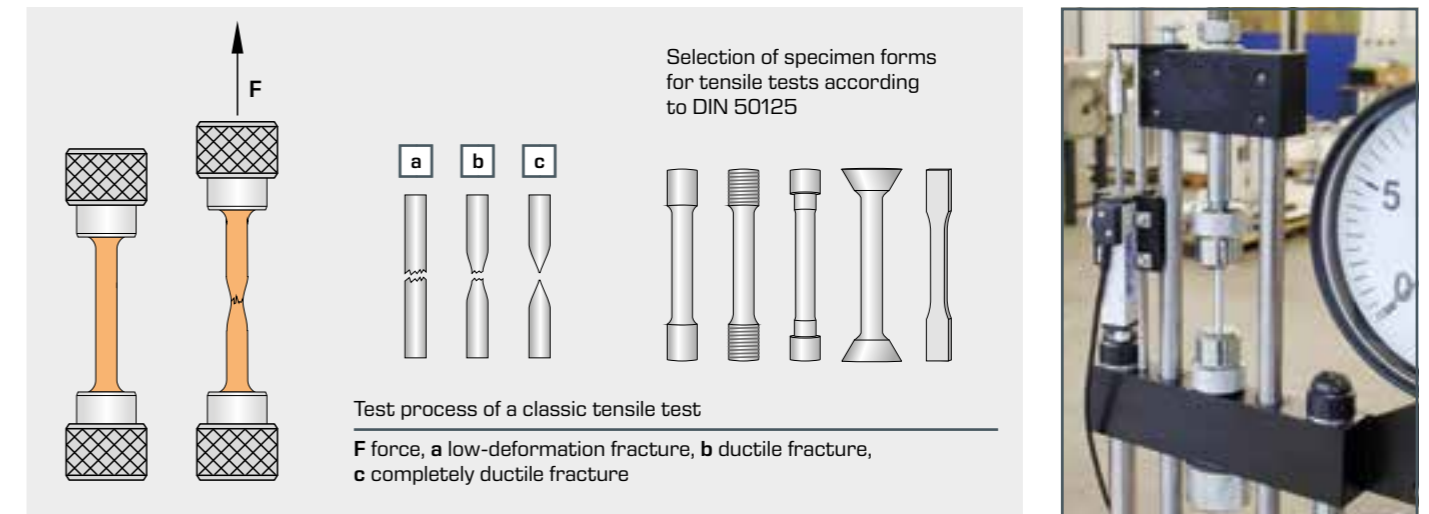

Stress-strain diagram

The stress-strain diagram shows clearly the different behaviour of the individual materials and provides the characteristic values for tensile strength R_m , yield strength R_e , proportional limit R_p , elongation at fracture A and the elastic modulus E .

σ stress, ϵ strain, R_p proportional limit, R_e yield strength, R_m tensile strength, A elongation at fracture
 1 Hooke's straight line, 2 Lüders strain, 3 strain hardening region, 4 start of contraction, 5 fracture

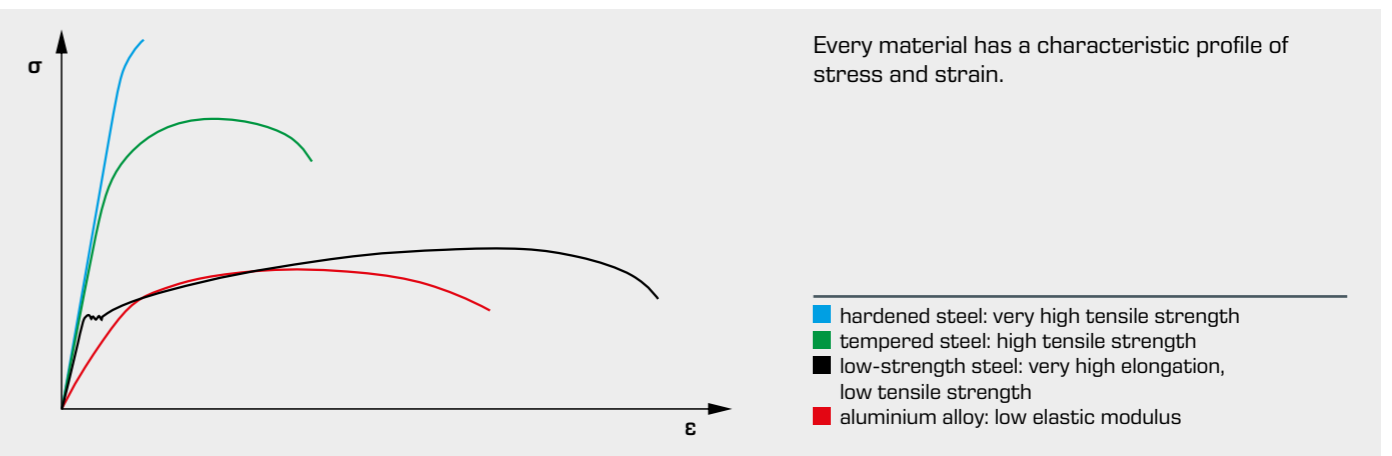
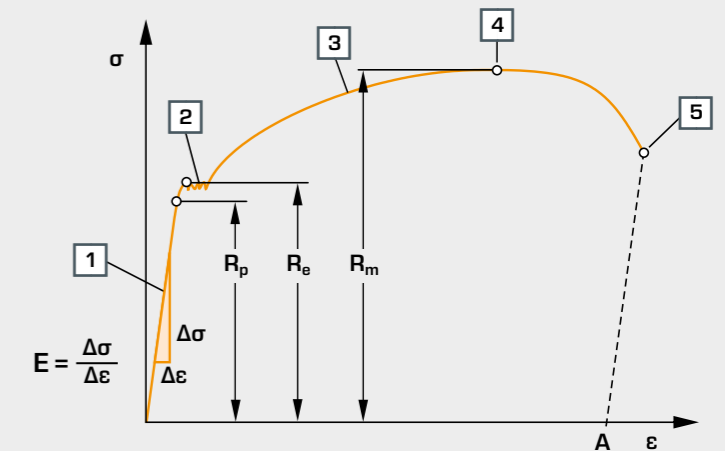

Mechanical testing methods

Compression test to determine flow curves

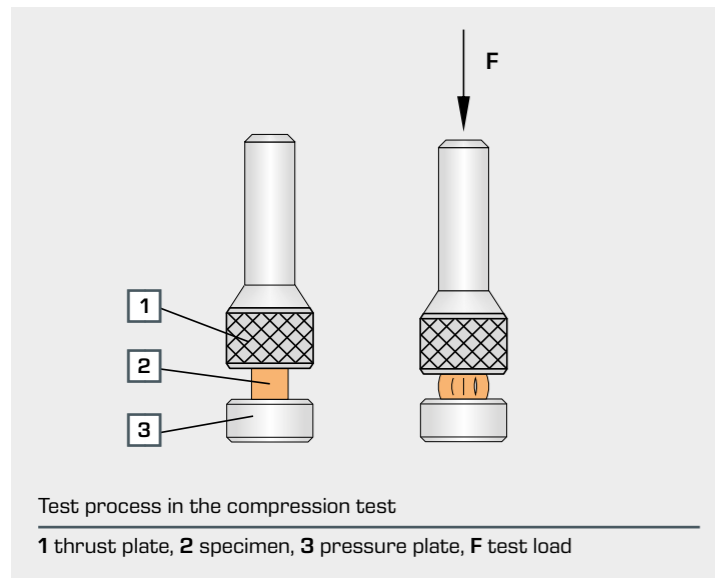

Compression tests are less significant for testing metallic materials compared to tensile tests. However, when studying building materials such as natural stone, brick, concrete, wood etc., the compression test is fundamentally important. A standardised specimen with a known cross section is loaded uniformly with low increasing force in the longitudinal direction. A uniaxial stress state prevails in the specimen. The ratio of stress to compression can be shown from the plotted force-path diagram. The **stress-compression diagram** shows clearly the different behaviour of the various separate materials and provides the characteristic values for compression strength, 0,2% offset yield point and the compression yield stress.

Stress-compression diagram

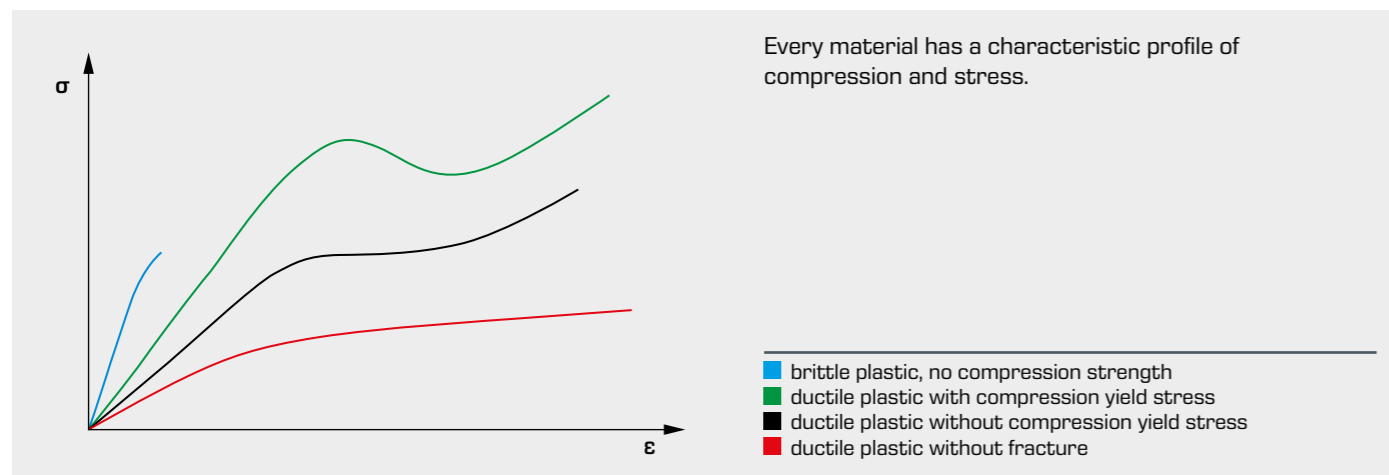
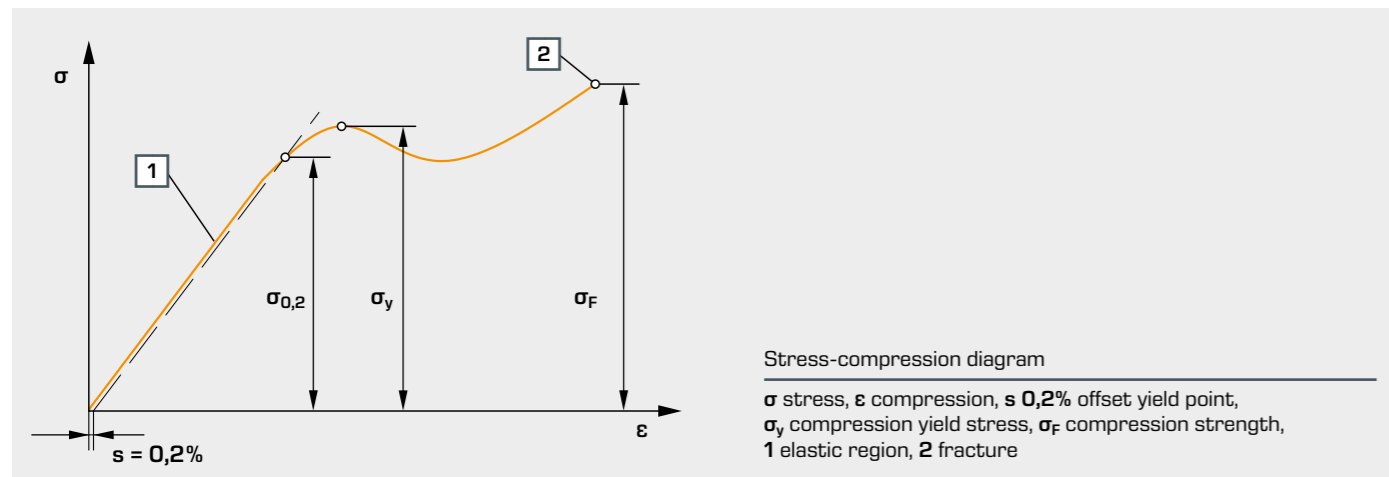

Various methods for determining hardness

Hardness refers to the mechanical resistance with which a body opposes the intrusion of another body.

Principle of the Brinell hardness test

In this test method, a standardised test body – a hard metal sphere – is pressed into the workpiece under defined conditions. The surface of the lasting impression is then measured optically. The impression surface is calculated from the impression diameter and the sphere diameter. A triaxial stress state develops in the specimen, underneath the impressing test body.

The Brinell hardness is calculated from the test load and impression surface of the spherical segment.

$$HB = \frac{0,102 \cdot F}{A_B} \quad 0,102 = \frac{1}{9,81} = \frac{1}{g}$$

to convert N into kgf

HB Brinell hardness value, F test load in N, A_B impression surface in mm², g=9,81 gravitational acceleration

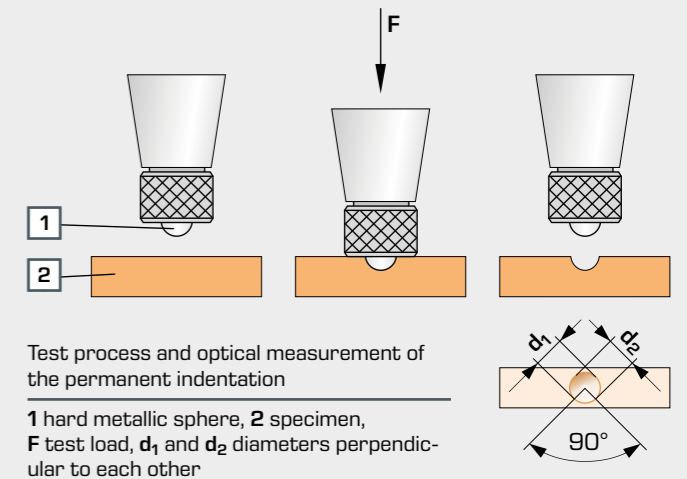

Principle of the Vickers hardness test

The test method is similar to the Brinell hardness test. Unlike the Brinell method, a pyramid-shaped diamond is used as the test body. The impression diagonal is determined by measuring the two diagonals d₁ and d₂ and by taking the average. The Vickers hardness is the quotient of the test load and impression surface.

Test process and optical measurement of the permanent indentation

1 pyramid-shaped diamond, 2 specimen, F test load, d₁ and d₂ diagonals

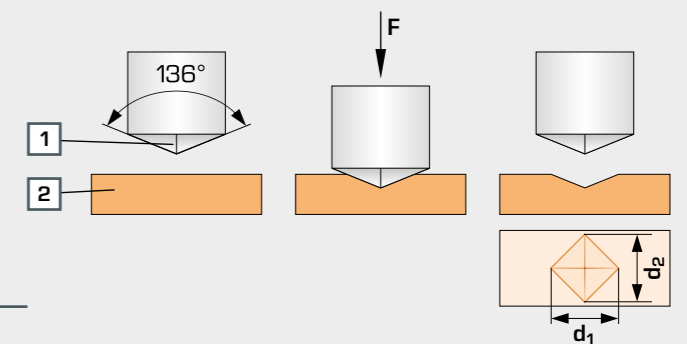

Principle of the Rockwell hardness test

Rockwell's hardness test method allows the hardness to be read directly on a dial gauge as the difference of the depths of penetration.

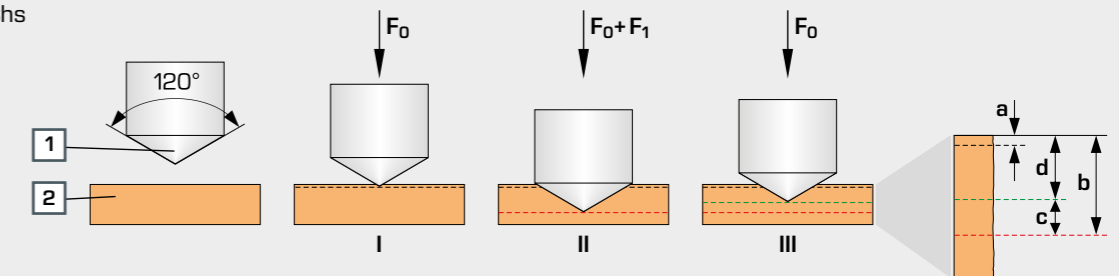

Test process and measurement of the depth of penetration

1 diamond cone, 2 specimen, I test pre-load F₀ is applied to the test body and the dial gauge is set to zero, II additional test load F₁ is applied for a given duration, III additional test load F₁ is removed, a depth of penetration due to test pre-load F₀, b depth of penetration due to additional test load F₁, c elastic recovery after removal of the additional test load F₁, d lasting depth of penetration h

Mechanical testing methods

Bending tests for the study of deformation behaviour

The most frequently studied bending load in materials testing is the three-point bending test. Using this method, a beam mounted on two supports is studied under a single force applied to the centre. The bending test demonstrates the relationship

between the load of a bending beam and its elastic deformation. The effects of modulus of elasticity and second moment of area are shown.

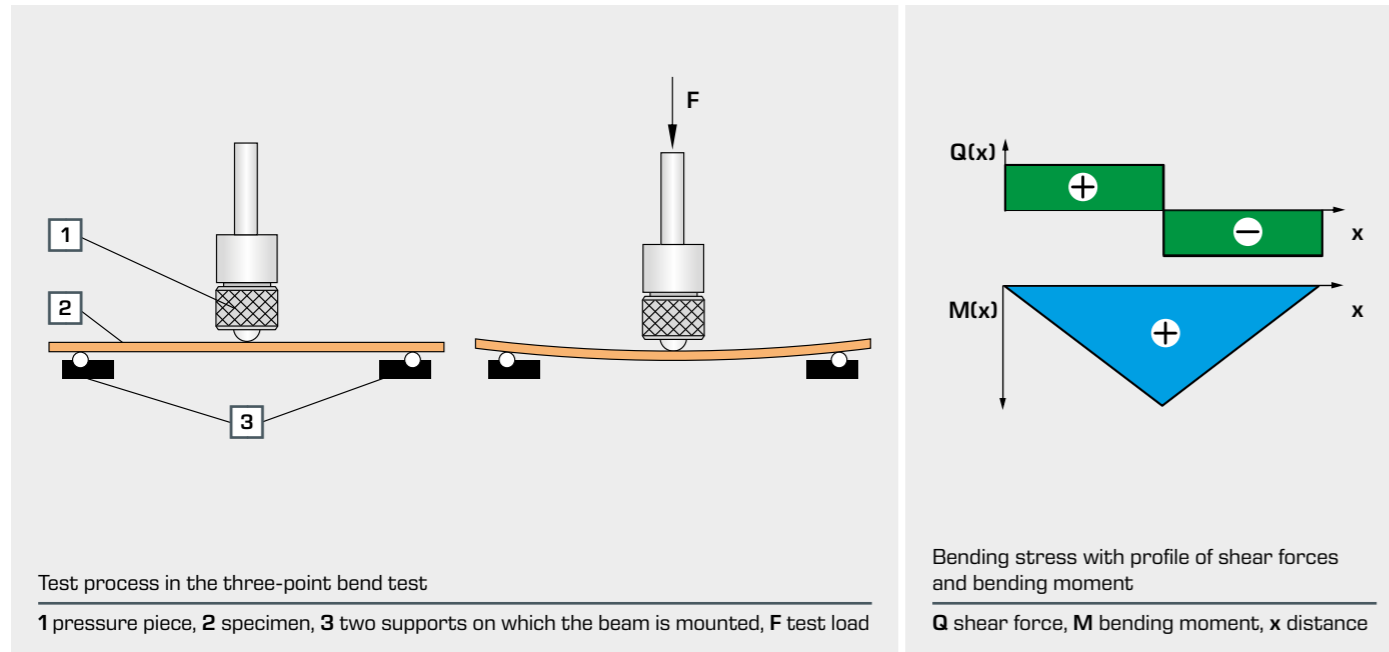

Cupping test to determine the cupping capacity (cold formability) of sheets and strips

Sheets and strips are subject to high demands in terms of their cold formability for deep drawing. No cracks are allowed to occur when working with these thin sheets.

The cupping test checks the cold formability in sheets.

The cupping specimen to be tested is clamped between a blank holder and die and is indented with a hardened spherical stamp (cupped) until the specimen cracks. The depth achieved is considered a standard of comparison for the cold formability. In addition, the type of crack and the surface structure of the sagging area are analysed.

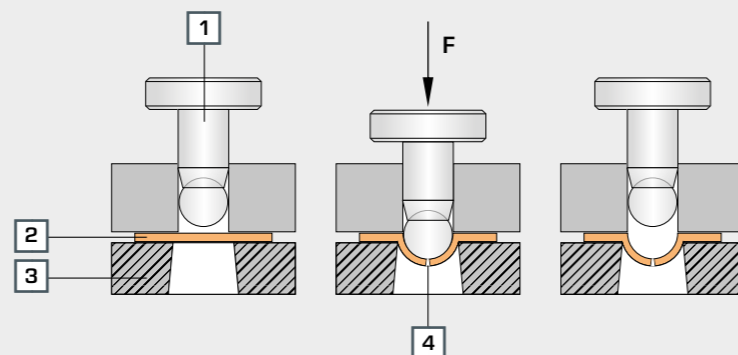

Shear test to study the load capacity against shearing

The shear test is applied when testing screws, rivets, pins and parallel keys in order to determine the shear strength of the material or the behaviour of the material under shear strain. To do this, the shear stresses are produced in the specimen by

means of external shear forces until the specimen shears off. The resistance of a material against the shear stress can be determined by two different methods, the single-shear and the double-shear testing method.

In the double-shear method, the specimen is sheared off at two cross sections. In the single-shear process, the specimen only shears away at one cross section. Calculating the shear strength in the two processes differs in the cross-sectional area to be applied. The shear strength determined in the shear test is important in the design of bolts, rivets and pins, as well as for calculating the force required for shears and presses.

$$\tau = \frac{F}{2 \cdot A}$$

Shear strength in the double-shear method

τ shear strength, F force, A shearing surface

Test process in the double-shear test

1 pull strap, 2 specimen, 3 housing, F test load

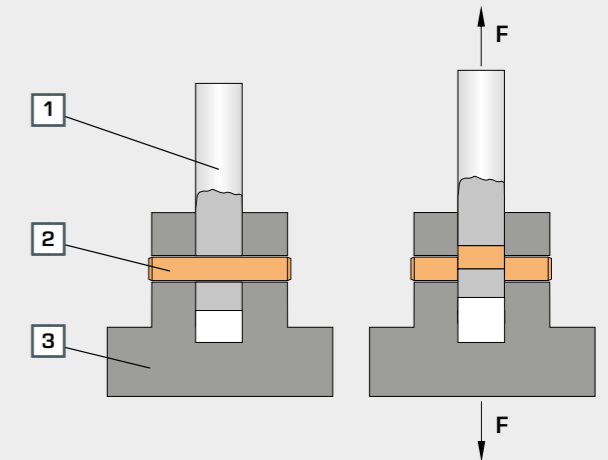

Torsion test to study the plastic behaviour of materials

Components that are subjected to rotary movements are twisted. This twisting is referred to as torsion. The torsional stiffness determined in the torsion test serves as orientation

for the load capacity of the material. This method is applied in shafts, axles, wires and springs and to assess the impact behaviour of tool steels.

In the torsion test, a specimen is clamped at one end and subjected to the load of a steadily increasing moment, known as the twisting moment or torsional moment. The twisting moment causes shear stresses in the cross-section of the specimen and a stress state that leads to deformation and ultimately to fracture.



Test process in the torsion test

1 rigid clamping, 2 specimen, 3 rotating clamping, 4 drive; M_t twisting moment, γ shearing angle, ϕ twisting angle, τ shear stress

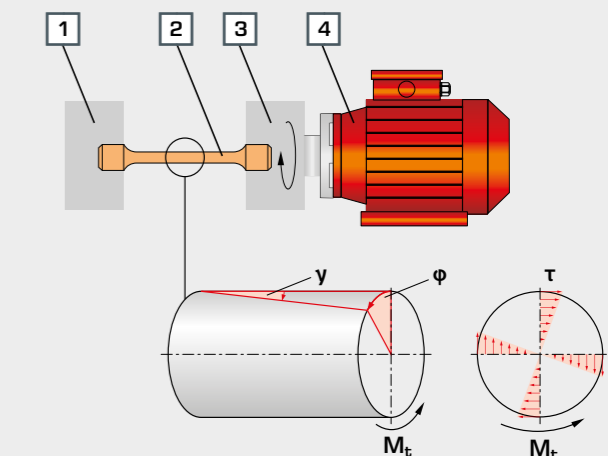

Mechanical testing methods

Impact test to determine the toughness property

The impact test is a method with sudden loading and is suitable primarily for determining the cleavage fracture tendency or toughness property of a material. This test method does not provide any values of material characteristics. The determined values of the impact test, the notched-bar impact strength, do not fit directly into calculations on strength. Rather, they help only with a rough selection of materials for a specific task.

The deformation behaviour is often an important criterion for the selection of materials. It can be used to identify quickly which of the selected materials are brittle or tough. The brittleness of

the material does not depend on the material alone, but also on other external conditions such as temperature or stress state.

Different testing methods are used to determine the notched-bar impact strength. In the Charpy test, the test body is mounted on two sides and a pendulum strikes the centre of the test body at the height of the notch. In the Izod and Dynstat tests, the test body is upright and a pendulum strikes the free end of the test body above the notch.

Principle of the Charpy notched-bar impact test

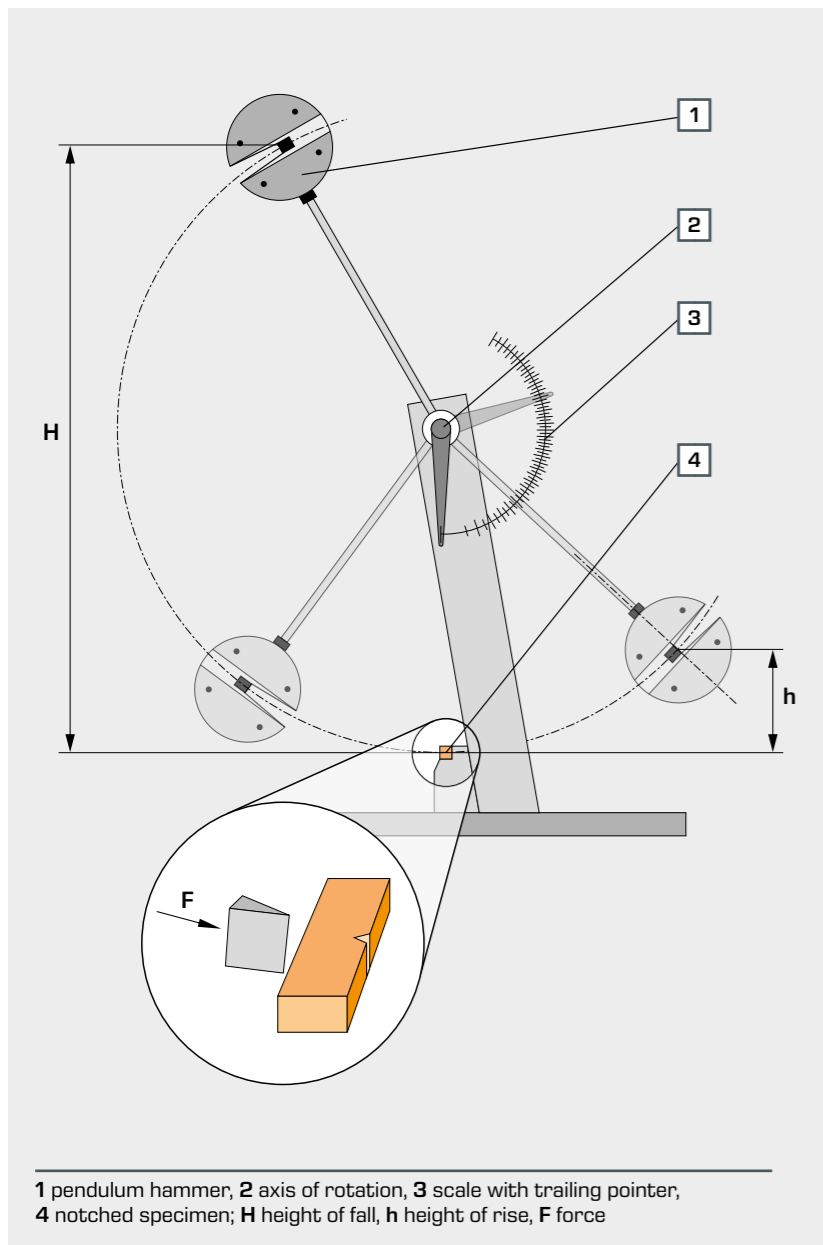

In the notched-bar impact test, a pendulum hammer falls down from a maximum height. At its lowest point, the hammer strikes the rear of a notched specimen according to Charpy's principle. If the abutment penetrates or passes through the specimen, the hammer dissipates its impact energy to the specimen. The residual energy of the hammer is reduced when swinging through the lowest possible point (zero point) and the hammer decelerates. When the hammer swings through the zero point, the trailing pointer is dragged along and the applied work for the notched-bar impact is displayed on a scale.

The shape of the notched-bar specimen is standardised.

The necessary notched-bar impact work is the force needed to penetrate a defined notched specimen. The notched-bar impact strength determined from the notched-bar impact work is a measure of the brittleness of the material.



Notched-bar impact work-temperature diagram

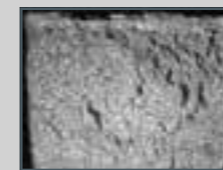
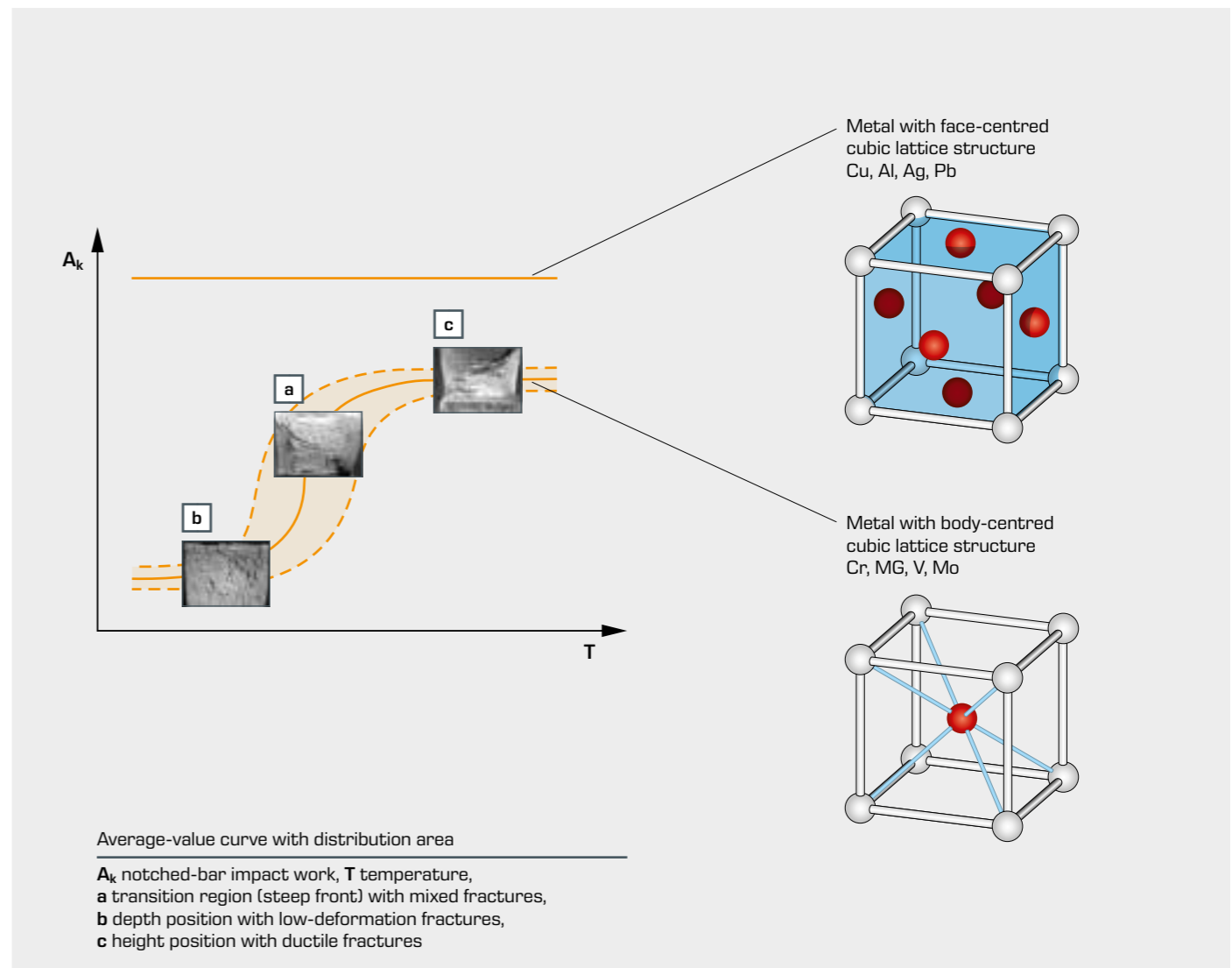

Low-deformation fracture (brittle materials)

- material separation by direct stress over cleavage planes
- trans-crystalline fracture
- glossy, practically deformation-free fracture surface



Mixed fracture

- external ductile fracture (microscopic honeycomb fracture), internal low-deformation fracture (microscopic cleavage fracture)



Ductile fracture (tough materials)

- ductile deformation, fracture due to grains
- matte, heavily deformed fracture surface

Mechanical testing methods

Material fatigue

Fatigue strength test

The fatigue strength defines the load limit up to which a material that is loaded dynamically withstands without breaking. Moving machine parts in particular are subject to dynamic loads, caused by vibrations for example. In this case, a fracture occurs after a

high number of load cycles with stresses that are far below the yield point and far below the fracture stress.

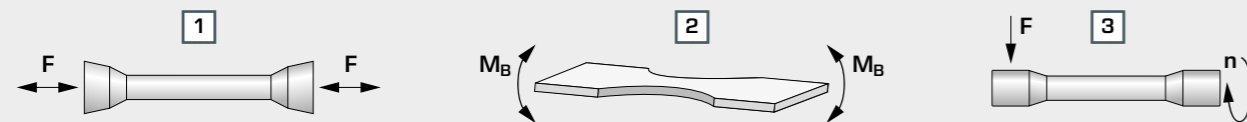

Differently loaded specimens

1 specimen with tensile and compression stress, 2 specimen with stress from alternating bending, 3 specimen with stress from rotary bending; F force, M_B bending moment, n speed

Principle of the fatigue strength test with stress on rotary bending

In the fatigue strength test, a rotating, cantilever-mounted specimen is subjected to a bending moment. In the cylindrical specimen, this creates an alternating stress due to rotary bending. After a certain number of load cycles, the specimen fractures because of material fatigue.

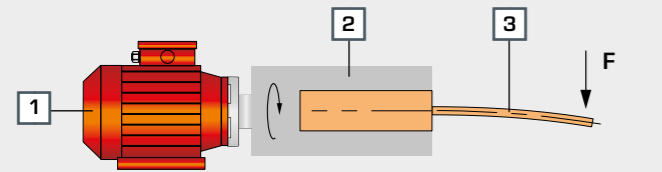

1 drive, 2 rigid clamp, 3 rotating specimen



Analysis of the fracture surface following the fatigue strength test

1 to 3 fatigue fracture, 4 final force fracture

Wöhler diagram for analysis of the experiment

The relationship between load change until fracture and the associated stress load is plotted in a Wöhler diagram.

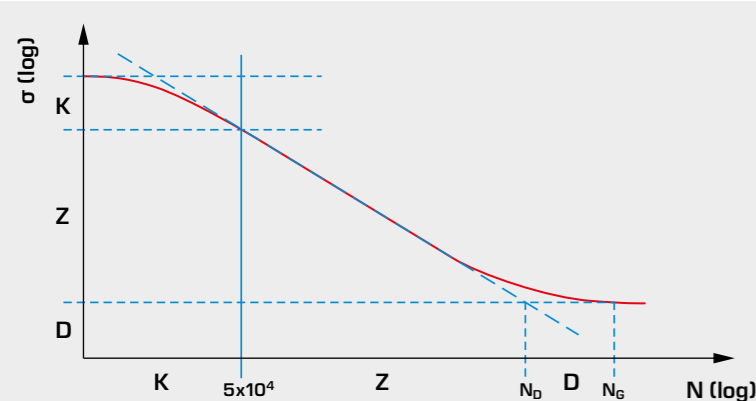

N load cycles, σ stress load, K short-term strength, Z fatigue strength, D endurance strength, N_D number of load cycles from endurance strength is given, N_G limit load cycles

The Wöhler diagram contains three regions:

Short-term strength: exceeds a load limit at which the specimen will be damaged in principle

Fatigue strength: with increasing load, there is a decreasing number of load cycles until fracture of the specimen

Endurance strength: maximum stress that a specimen can endure indefinitely and without perceptible deformation, at least up to the number of load cycles N_G

Service life: Number N of load cycles until fracture at a certain load

Creep rupture test to study creep

Materials behave differently under lasting static loads at increased temperatures than they do under the same load at room temperature. After a certain amount of time, increased temperatures under stresses below the hot yield point and

without an increase in load lead to a slow but steady irreversible plastic deformation, also known as creep. After a sufficiently long, even load time, this leads to fracture of the specimen.

Principle of the creep rupture test

In the creep rupture test, a specimen is subjected to load at constant stress and constant temperature. This experiment is performed multiple times with different stresses, but always at the same temperature. The plastic deformations are measured in continuous intervals. All measured values can then be transferred to a creep diagram. The measured elongation shows

a characteristic curve, which is known as the creep curve. The creep rupture test determines the characteristic values for the creep strength and the various strain values.

Creep curve

If the elongation is plotted over time, we get the creep curve.

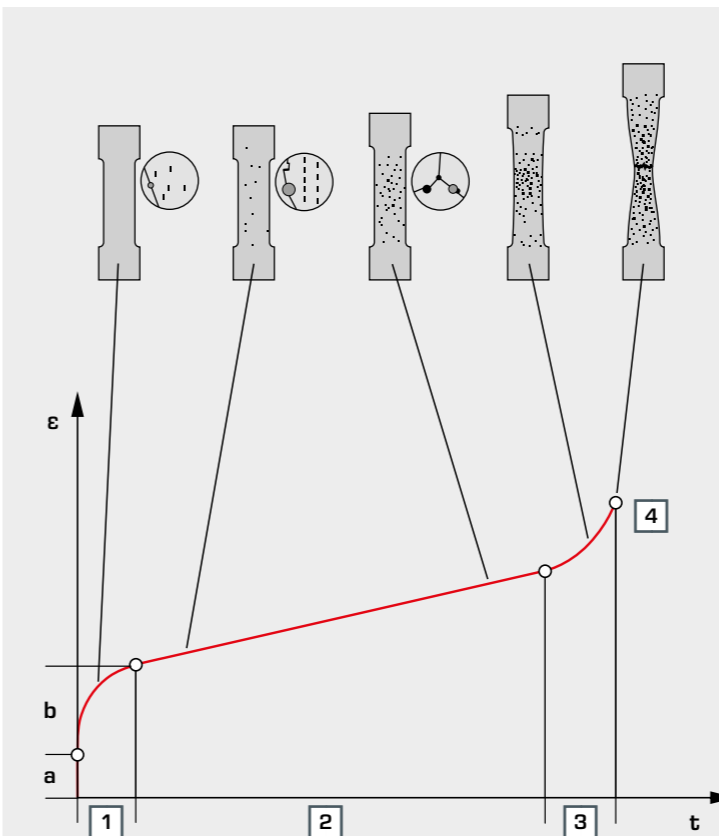

Change in the specimen over time

t time, ϵ elongation, 1 primary creep, 2 secondary creep, 3 tertiary creep, 4 specimen fracture, a elastic deformation, b plastic deformation

Creep strength (creep fracture limit / creep strain limit): mechanical stress, which causes permanent elongation or fracture

Strain values: creep, permanent elongation, plastic initial strain, inelastic recovery

In the creep curve we differentiate between three phases in technical creep regions:

Phase 1, the primary creep with decrease of the initially very high creep rate. Here, the influence of the material strength prevails (rapid creep).

Phase 2, the secondary creep with virtually constant creep rate. The dislocation climb when overcoming flow obstacles is located in a steady-state equilibrium.

Phase 3, the tertiary creep with again increasing creep rate until fracture due to increasing necking and increase in the effective stresses. Phase 3 can be very short in the case of low-deformation fractures.

Course
Fundamentals of materials testing

Series WP

A complete course
in the fundamentals
of materials testing

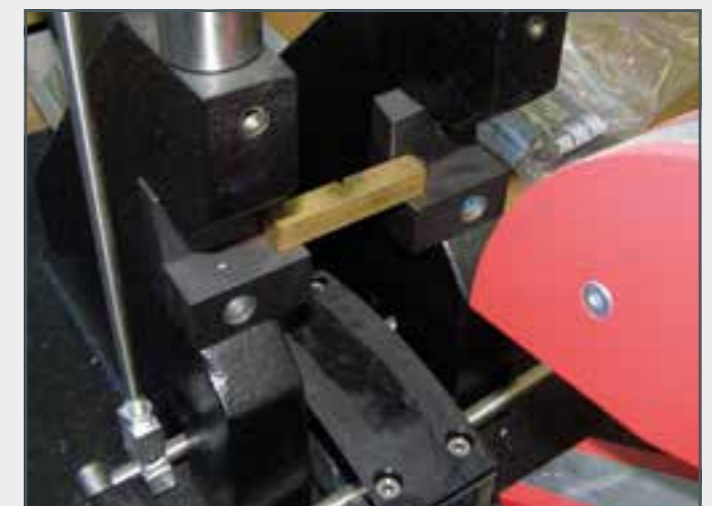
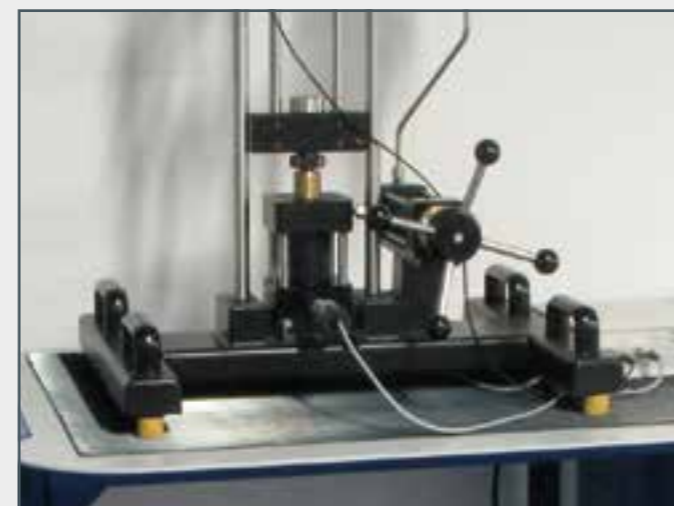
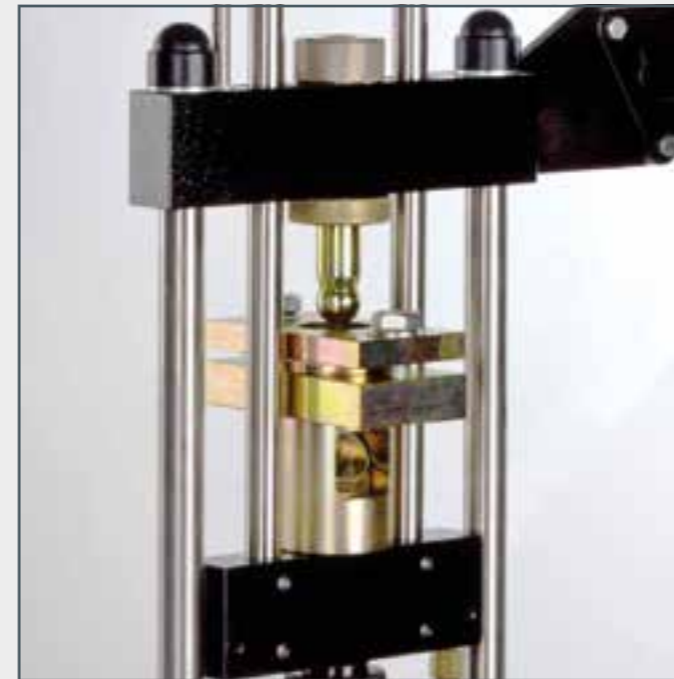

Course

Fundamentals of materials testing

Using experimental units, students learn how to analyse materials by learning about different test methods for determining material properties and for assessing and classifying "unknown" materials.

The complete course includes topics such as:

- elastic and plastic deformation
- tensile strength, stress, strain, force-extension diagram, stress-strain diagram
- elongation at fracture, necking, fracture behaviour
- Brinell hardness test
- compression test, compression strength, compression yield stress, stress-compression diagram
- bending test
- cupping test, cold formability
- shear test, shear strength
- torsion test, torsion, shear stress, torsional stiffness, impact behaviour
- Charpy notched-bar impact test, toughness property, notched-bar-impact work-temperature diagram
- fatigue strength test, Wöhler diagram, analysis of the fracture surface
- creep rupture test, creep, strain-time diagram (creep curve)



The compact WP 300 experimental unit generates a 20kN test load

- classic experiments from destructive materials testing
- observation of the experiment in all details and phases
- clear demonstration of relationships between rising forces and change in various materials
- mobile use thanks to compact and lightweight design
- preparation display and storage of data with the WP 300.20 system for data acquisition



The compact WP 500 experimental unit generates reference moments of 30Nm

- generates the twisting moment by means of a worm gear
- measure the twisting moment with strain-gauge measuring shaft and encoder for measuring the twisting angle
- the scope of delivery includes GUNT software for analysing the measured values



The WP 310 experimental unit generates a 50kN test load

- classic experiments from destructive materials testing with measuring results based on industrial standards
- trainer for experiments based on industrial standards
- acoustic overload signal for test loads
- the scope of delivery includes GUNT software for analysing the experimental data



The WP 510 experimental unit generates reference moments of 200Nm

- torsion test based on industrial standards; experiments conducted with the aid of a motor
- different torsional velocities, clockwise and anticlockwise
- microprocessor-based measuring technology
- the scope of delivery includes GUNT software for analysing the experimental data



The compact WP 400 experimental unit generates a 25Nm work capacity

- Charpy notched-bar impact test for quality control and analysis of the fracture behaviour in metallic materials
- pendulum impact tester based on DIN EN ISO 148-1
- various safety devices for conducting experiments safely and optional protective cover for the WP 400.50 operating area
- preparation display and storage with the WP 400.20 system for data acquisition



The compact WP 140 experimental unit is used to conduct fatigue strength tests

- fatigue strength of bars under reverse bending stress
- digital counter displays load cycles
- automatically shuts down when the test bar fractures
- preparation display and storage with the WP 140.20 system for data acquisition



The WP 410 experimental unit generates a 300Nm work capacity

- Charpy notched-bar impact test with increased work capacity
- pendulum impact tester based on industrial standards / DIN EN ISO 148-1
- safe experiments thanks to two-hand release of the hammer and optional protective cage for pendulum impact tester WP 410.50
- preparation display and storage with the WP 410.20 system for data acquisition



The compact WP 600 experimental unit is used to conduct creep rupture tests

- simple creep rupture tests with lead and plastic specimens
- experiments can be conducted at room temperature
- cooling elements allow experiments to be conducted below room temperature
- experiments last from a few minutes to an hour

Course

Fundamentals of materials testing

Accessories for various materials tests

WP 300, 20 kN test load

Tensile tests

WP 300.02	Set of 4 tensile specimens, Al, Cu, St, CuZn
WP 300.21	Set of 4 tensile specimens, Al
WP 300.22	Set of 4 tensile specimens, Cu
WP 300.23	Set of 4 tensile specimens, St
WP 300.24	Set of 4 tensile specimens, CuZn
WP 300.14	Clamping device for flat tensile specimens
WP 300.25	Set of 4 tensile specimens, flat, Al, Cu, St, CuZn

Compression tests

WP 300.05	Compression plates for compression tests, large
WP 300.70	Set of 4 compression specimens, gypsum
WP 300.71	Set of 4 compression specimens, wood
WP 300.72	Set of 4 compression specimens, plastic

Brinell hardness tests

WP 300.03	Set of 4 hardness specimens, Al, Cu, St, CuZn
WP 300.31	Set of 4 hardness specimens, Al
WP 300.32	Set of 4 hardness specimens, Cu
WP 300.33	Set of 4 hardness specimens, St
WP 300.34	Set of 4 hardness specimens, CuZn
WP 300.12	Measuring magnifier for Brinell hardness test

Bending tests

WP 300.04	Bending test device
------------------	---------------------

Cupping tests

WP 300.11	Device for cupping tests
WP 300.41	Set of 5 cupping specimens, Al
WP 300.42	Set of 5 cupping specimens, Cu
WP 300.43	Set of 5 cupping specimens, St
WP 300.44	Set of 5 cupping specimens, CuZn

Shear tests

WP 300.10	Device for shear tests, double-shear
WP 300.13	Device for shear test, single-shear
WP 300.52	Set of 5 shear specimens, Cu

Spring tests

WP 300.06	Experimental setup for spring test, helical spring, 2 sets
WP 300.07	Experimental setup for spring test, disk spring

WP 310, 50 kN test load

Tensile tests

WP 310.05	Clamping device for tensile specimens, round and flat
WP 310.12	Set of 10 tensile specimens F10x50 DIN 50125, St (S235JRC+C)
WP 310.06	Clamping device for tensile specimens, threaded end
WP 310.11	Set of 10 tensile specimens B10x50 DIN 50125 M16, St (S235JRC+C)
WP 310.07	Clamping device for tensile specimens, dumbbell-shaped
WP 310.13	Set of 10 tensile specimens, dumbbell-shaped, St (S235JRC+C)

Compression tests

WP 310.04	Compression plates for compression tests
WP 310.15	Set of compression specimens, 4x plastic, 1x wood

Brinell hardness tests

WP 310.01	Experimental setup for Brinell hardness test
WP 300.03	Set of 4 hardness specimens, Al, Cu, St, CuZn
WP 300.31	Set of 4 hardness specimens, Al
WP 300.32	Set of 4 hardness specimens, Cu
WP 300.33	Set of 4 hardness specimens, St
WP 300.34	Set of 4 hardness specimens, CuZn
WP 300.12	Measuring magnifier for Brinell hardness test

Bending tests

WP 310.03	Bending test device
WP 310.81	Set of 25 bending specimens, St

Cupping tests

WP 310.10	Device for cupping tests
WP 300.41	Set of 5 cupping specimens, Al
WP 300.42	Set of 5 cupping specimens, Cu
WP 300.43	Set of 5 cupping specimens, St
WP 300.44	Set of 5 cupping specimens, CuZn

Shear tests

WP 310.02	Device for shear tests, double-shear
WP 300.52	Set of 5 shear specimens, Cu

Spring tests

WP 310.08	Experimental setup for spring test, helical spring
WP 310.09	Experimental setup for spring test, disk spring

WP 400, 25 Nm test load

Impact test

WP 400.01	Set of 10 ISO-V specimens 10x5, construction steel (S235JRC+C)
WP 400.02	Set of 10 ISO-V specimens 10x5, CuZn
WP 400.03	Set of 10 ISO-V specimens 10x10, CuZn
WP 400.04	Set of 10 ISO-U specimens 10x5, free cutting steel (9SMn28)
WP 400.05	Set of 10 GUNT-R7 specimens, free cutting steel (9SMn28)
WP 400.06	Set of 10 GUNT-R5 specimens, free cutting steel (9SMn28)
WP 400.07	Set of 10 GUNT-R7 specimens, heat treatable steel (C45k)
WP 400.08	Set of 10 GUNT-R7 specimens, construction steel (S235JRC+C)
WP 400.09	Set of 10 GUNT-V specimens, construction steel (S235JRC+C)
WP 400.50	Safety cage for pendulum impact tester

WP 500, 30 Nm test load

Torsion test

WP 500.01	Set of 6 torsion specimens, St, Al, CuZn
------------------	--

Material fatigue with WP 140

Fatigue strength test

WP 140.01	Set of 3 specimens, various fillet radii, St
------------------	--

WP 410, 300 Nm test load

Impact test

WP 410.01	Set of 10 ISO-V specimens 10x10, St 37k
WP 410.02	Set of 10 ISO-V specimens 10x10, Cu
WP 410.03	Set of 10 ISO-V specimens 10x10, CuZn
WP 410.50	Safety cage for pendulum impact tester

WP 510, 200 Nm test load

Torsion test

WP 510.01	Set of 5 torsion specimens, St
WP 510.02	Set of 5 torsion specimens, CuZn
WP 510.03	Set of 5 torsion specimens, Al

Material fatigue with WP 600

Creep rupture test

WP 600.01	Set of 10 specimens, PE
WP 600.02	Set of 10 specimens, Pb

Accessories

WP 300.09	Laboratory trolley
------------------	--------------------

Systems for data acquisition

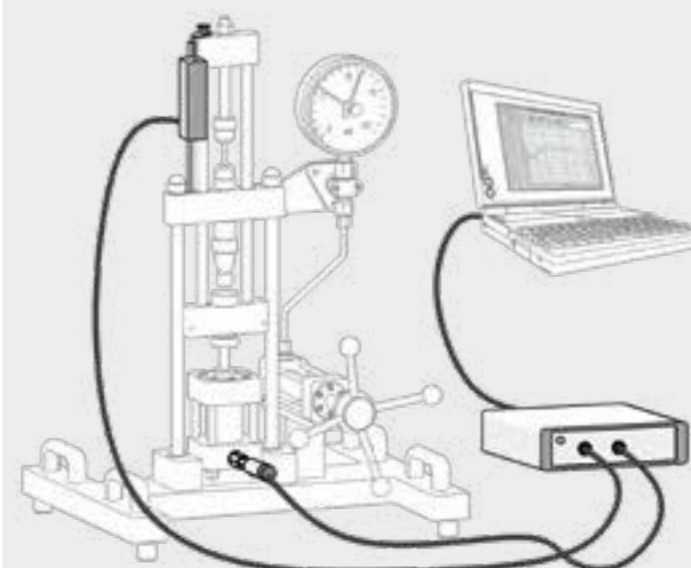

GUNT software

- supports various materials tests
- record typical diagrams, e.g. stress-strain diagram, notched bar impact work-temperature diagram
- complete test record according to DIN (tensile and compression test)
- prepare, display and store data
- in WP 140, WP 300, WP 400, WP 410 optionally available
- in WP 310, WP 500, WP 510 included in scope of delivery

WP 300

Materials testing, 20kN



Learning objectives/experiments

- tensile tests
- plot stress-strain diagrams
- Brinell hardness test
- together with the accessories
 - ▶ compression tests
 - ▶ bending tests
 - ▶ cupping tests
 - ▶ shear tests
 - ▶ testing of plate and coil springs

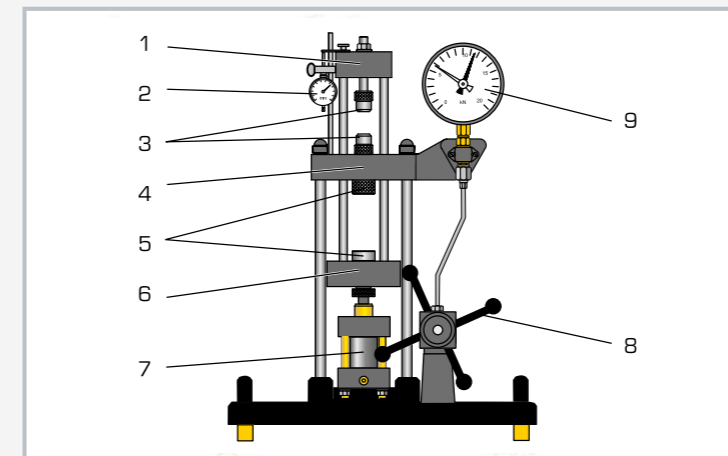

1 upper cross-member, 2 dial gauge for elongation, 3 clamp for tensile specimens, 4 crosshead, 5 compression piece and pressure plate, 6 lower cross-member, 7 hydraulic cylinder, 8 hand wheel, 9 force gauge

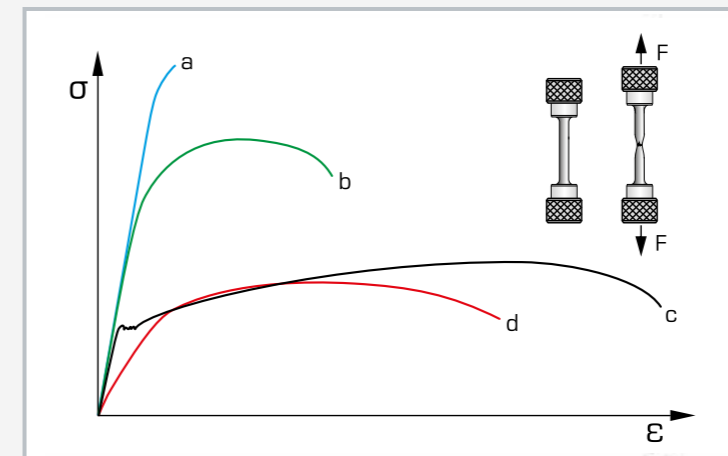

Stress-strain diagram for various materials: a hardened steel, b tempered steel, c annealed steel, d alloyed aluminium

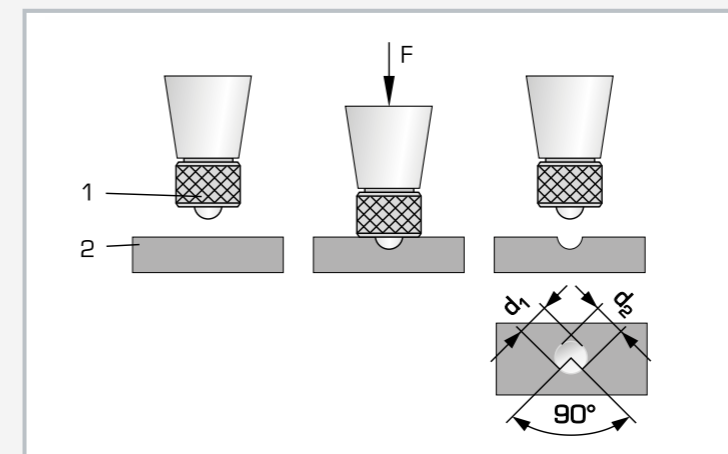

Brinell hardness test: 1 hardened steel ball, 2 specimen; F test load, d_1 and d_2 dimensions of the impression surface

Specification

- [1] classic experiments from destructive materials testing
- [2] tensile tests, Brinell hardness test
- [3] extensive accessories available for further experiments
- [4] generation of tensile and compressive forces
- [5] forces generated by hand-operated hydraulic system; no power supply required
- [6] force gauge, pointer instrument with drag indicator
- [7] dial gauge for determining the elongation
- [8] 16 hardness specimens
- [9] 16 tensile specimens B6x30 according to DIN 50125
- [10] system for data acquisition (WP 3000.20) available as an option

Technical data

Test force: max. 20kN
Stroke: max. 45mm
Free installation space for specimens: 165x65mm

16 tensile specimens
■ material: 4x Al, 4x Cu, 4x St, 4x CuZn

16 hardness specimens
■ LxWxH: 30x30x10mm
■ material: 4x Al, 4x Cu, 4x St, 4x CuZn
Sphere for hardness testing: \varnothing 10mm

Measuring ranges

- force: 0...20kN, graduation: 0,5kN
- travel: 0...20mm, graduation: 0,01mm

LxWxH: 610x500x860mm
Weight: approx. 48kg

Scope of delivery

- 1 experimental unit
- 1 device for hardness test
- 1 force gauge
- 1 elongation dial gauge
- 4 sets of tensile specimens (4 pieces each)
- 4 sets of hardness specimens (4 pieces each)
- 1 set of instructional material

Description

- compact, simple experimental unit for basic destructive tests
- tensile tests, Brinell hardness test

A solid understanding of the properties of materials is essential for technical and scientific professions. This knowledge helps select the suitable material, monitor production and processing and ensure the requirements in terms of a component. The materials test provides the necessary data in a reproducible and precisely quantified manner. The tensile test, bending test and hardness test are all part of classic destructive materials testing.

The range of experiments with WP 300 covers tensile tests and Brinell hardness tests in the base unit.

Compression, bending, shear and cupping tests can be conducted using the accessories. Plate and coil springs can also be tested. The experimental unit has been developed specifically for experiments in small groups and is characterised by a clear design, simple operation and accessories that are easy to exchange.

The tensile specimens are clamped between the upper cross member and the crosshead. The hardness specimens are secured between the crosshead and lower cross member. The test force is generated by means of a hand-operated hydraulic system and displayed on a large force gauge with drag indicator. A dial gauge measures the elongation of the specimens.

The experimental unit can also be equipped with electronic force and displacement measurement. Using the WP 300.20 system for data acquisition, the measured values for force and displacement can be transferred to a PC where they can be analysed with the software.

WP 310

Materials testing, 50kN



The illustration shows WP 310 together with the accessory WP 310.05.

Learning objectives/experiments

- together with the accessories
 - ▶ tensile test
 - ▶ compression test
 - ▶ Brinell hardness test
 - ▶ bending test
 - ▶ shear test
 - ▶ cupping test
 - ▶ spring testing

Description

- hydraulically operated trainer, based on industrial standards
- direct generation of tensile and compressive forces
- extensive accessories for experiments from destructive materials testing

A classic discipline of materials testing is the destructive testing method, in which specimens are mechanically tested to failure. The materials test provides data for hardness, rigidity and strength in a reproducible and precisely quantified manner.

The WP 310 unit, in conjunction with the accessories, offers experiments from destructive materials testing.

The clean layout and simple operation mean the experimental sequence can be observed in all details and phases. The power of the trainer allows tests to be performed on an industrial scale. Material specification data and laws can be verified using self-determined measured values.

The vertical, hydraulically operated trainer with direct force generation can produce both tensile and compressive forces. The height of the lower cross-member can be adjusted for coarse adjustment. Cylindrical receptacles on the cross-members allow for easy exchange of accessories.

The extensive accessories provide tensile and compression tests, Brinell hardness tests, bending, shear and cupping tests. Plate and coil springs can also be tested. The test load and elongation of the specimen are measured by sensors and are displayed.

The measured values are transmitted directly to a PC where they can be analysed using the software included.



1 hydraulic cylinder for generating tensile and compressive forces, 2 operating area with the accessory WP 310.05, 3 force sensor, 4 adjustable height lower cross-member with lock, 5 displays and controls, 6 displacement sensor

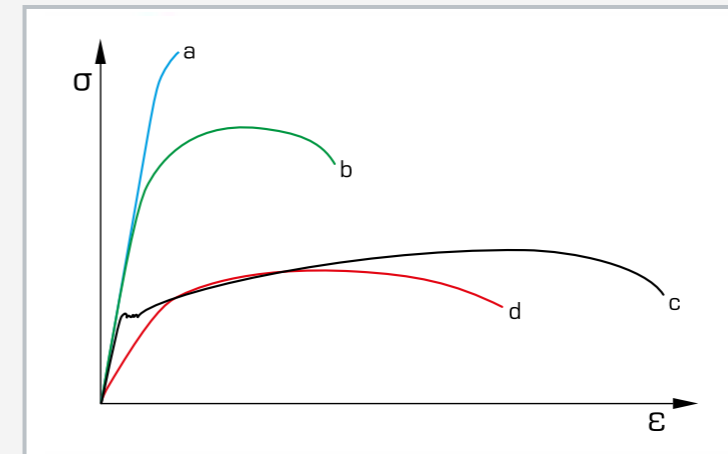

Stress-strain diagram for various materials: a hardened steel, b tempered steel, c annealed steel, d alloyed aluminium



Software screenshot: Brinell hardness test

Specification

- [1] hydraulically operated trainer for materials testing, based on industrial standards
- [2] generation of tensile and compressive forces
- [3] adjustable test load and travel velocity
- [4] generation of test load via gear pump and double-acting hydraulic cylinder
- [5] force measurement via a strain-gauge full bridge with acoustic overload signal, max. overload 150%
- [6] displacement measurement via linear potentiometer
- [7] LED displays for force and displacement with tare and maximum-value storage
- [8] GUNT software for data acquisition via USB under Windows 7, 8.1, 10
- [9] wide range of accessories available

Technical data

- Operating area, WxH: 300x925mm
Hydraulic generation of the test load
- test load: 0...50kN
 - max. system pressure: 175bar
 - max. piston stroke: 150mm
 - traverse velocity: 0...425mm/min
 - gear pump
 - ▶ max. flow rate: 1 cm³/revolution
 - ▶ power consumption: 0,55kW

Measuring ranges

- force: 0...50kN
- displacement: 0...150mm

230V, 50Hz, 1 phase
230V, 60Hz, 1 phase; 120V, 60Hz, 1 phase
UL/CSA optional
LxWxH: 1080x830x2300mm
Weight: approx. 330kg

Required for operation

PC with Windows recommended

Scope of delivery

- 1 trainer
- 1 GUNT software CD + USB cable
- 1 set of instructional material

SE 100

Frame for load testing, 400kN



The illustration shows SE 100 together with various accessories

Description

- load tests on components from steelwork and civil engineering
- specially designed for large components at a 1:1 scale
- wide range of applications thanks to extensive accessories

The demands of modern, technically sophisticated designs require a solid understanding of the strength and deformation of components. Different load states can be simulated in load experiments and the reaction to the load recorded and analysed. This makes it possible to demonstrate the load bearing capacity of the design by means of experiment. The SE 100 frame for load tests has been designed specifically for experiments in the fields of steelwork and civil engineering. Large components at a 1:1 scale are studied.

The frame is delivered in prefabricated parts that must be assembled on site. This makes it possible to transport the separate parts through normal doorways. The frame is set up on four adjustable and vibration-damping feet. The generous operating area is designed as a double frame so that longer components can also be studied.

The design of the frame means experiments can be conducted quickly and without complicated assembly. The unit offers a very wide range of possibilities in conjunction with the accessories and the load application device.

The hydraulically operated load application device, available as accessory SE 100.12, includes a double-action hydraulic cylinder and a hand-operated pump mounted on a table.

The load application device is mounted on rollers and can be positioned at any point on the upper cross-member of the frame. Depending on the experimental setup, it is also possible to use two load application devices (SE 100.02) and therefore generate several forces. The bending is indicated by means of dial gauges, available as accessory SE 100.03.

Large components such as reinforced concrete beams, girders or steel frames can be subjected to loads and investigated experimentally. The SE 100.04 accessory is available for experiments on trusses. The forces on typical bars of the truss are recorded by means of strain gauges.

Learning objectives/experiments

- together with the accessories
 - ▶ bending tests
 - ▶ load tests
 - ▶ compression tests

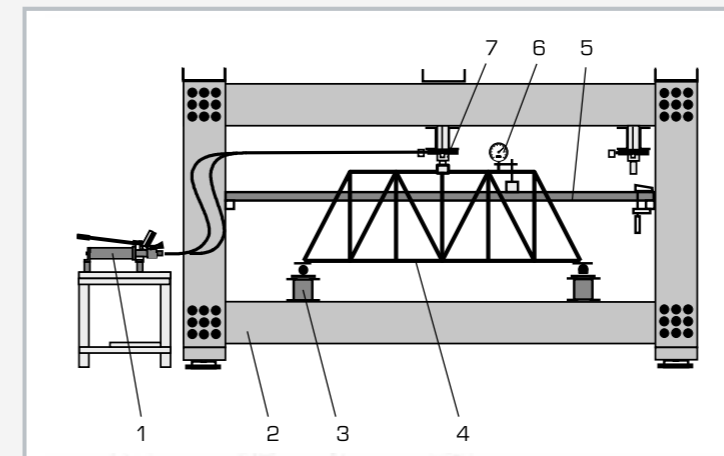

1 pump for load application device, 2 frame, 3 support SE 100.01, 4 plane truss SE 100.04, 5 measuring traverse, 6 dial gauge SE 100.03, 7 load application device SE 100.02

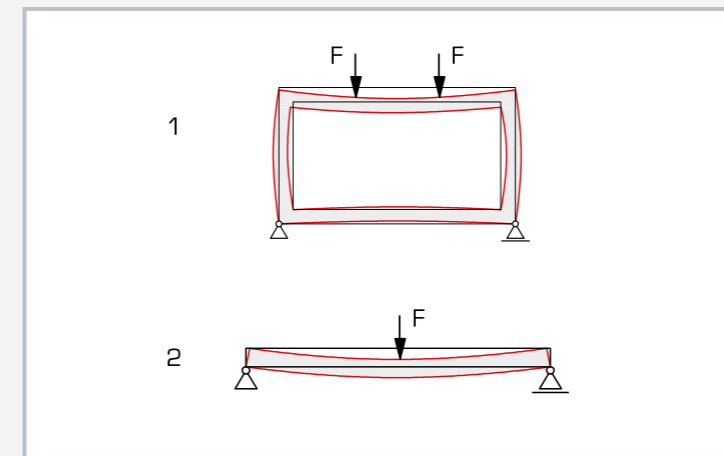

Suggestions for your own tests with various large components, for example 1 load on frame, 2 load on beam or girder

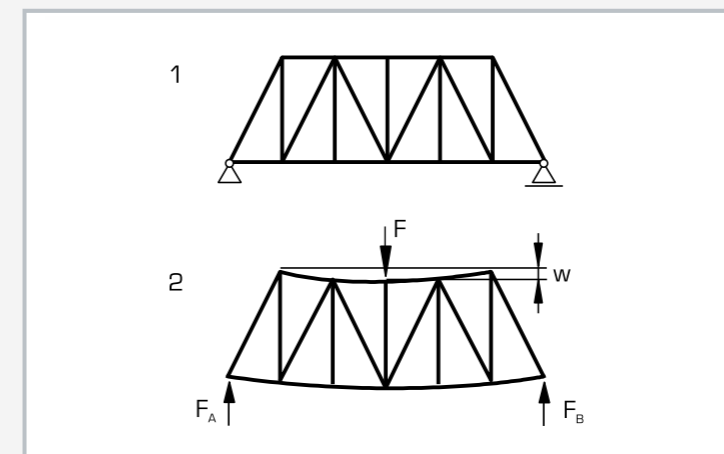

Bend test on a plane truss SE 100.04; 1 unloaded truss, 2 loaded truss, F test load, F_A and F_B support forces, w bending

Specification

- [1] investigation of components at 1:1 scale from steelwork and civil engineering
- [2] frame is delivered in parts, transport through normal doorways possible
- [3] large operating area, designed as a double frame, also suitable for very long components
- [4] mounted on 4 adjustable vibration-damping feet
- [5] hydraulically operated load application device for generating compressive forces available as an accessory
- [6] optionally available load application device mounted on rollers; SE 100.12 contains 1 load application device, SE 100.02 contains 2 load application devices
- [7] load application devices can be positioned at any point on the frame
- [8] experiments with different components such as beams, girders or frames possible
- [9] plane truss with strain gauge for force measurement available as accessory SE 100.04

Technical data

Frame

- steel profiles: U 400, St52
- frame opening WxH: 4100x1700mm
- clear span in the double frame: 635mm

Test loads

- centre position: max. 300kN
- off-centre: max. 2x 200kN

LxWxH: 5000x1350x2820mm

Weight: approx. 2600kg

Scope of delivery

- 1 frame of steel profiles

SE 110.48**Bending test, plastic deformation**

The illustration shows SE 110.48 in a frame similar to SE 112.

Description

- observe and determine the transition from elastic to plastic deformation
- plot load-extension diagrams

Mechanical stress, to which design elements are generally exposed, generates stresses in the affected component or the material. If these stresses are too large, there is plastic deformation of the material in addition to the elastic, reversible deformation. The component does not return fully to its original form after the deformation, resulting in a change of shape.

The beam studied in SE 110.48 is mounted on both sides. A movable and a fixed support are included in the scope of delivery to secure the beam. The beam is loaded with a point load. The load application device can be positioned anywhere on the frame. A dial gauge records the deformation. Beams of different materials and profiles are included in the scope of delivery.

The transition from elastic to plastic deformation is observed and determined in the experiment. The values obtained are used to create a load-extension diagram, in which the nonlinear behaviour of the deformation is demonstrated.

The parts of the experiment are laid out clearly and housed securely in a storage system. The entire experimental setup is constructed in the SE 112 mounting frame.

Learning objectives/experiments

- load on a beam with a point load
- plot a load-extension diagram and determine the nonlinear behaviour
- compare the load and relief curves
- demonstrate the invalidity of the superposition principle in the plastic region

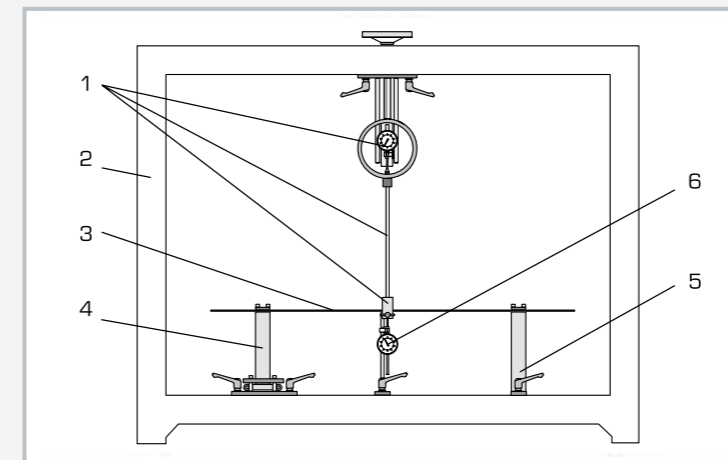

1 load application device, 2 SE 112 frame, 3 beam, 4 movable support, 5 fixed support, 6 dial gauge

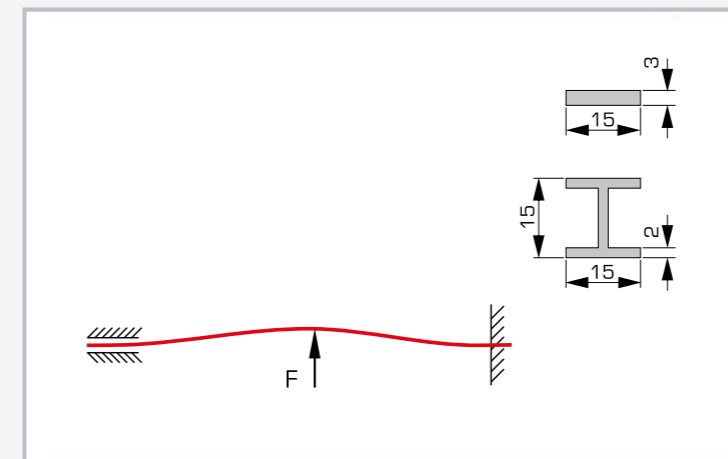

Plastic deformation of a beam, both beam profiles included in the scope of delivery

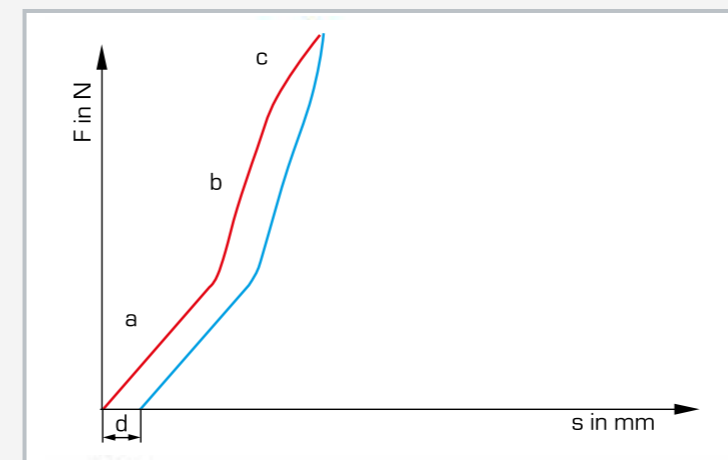

Load-extension diagram for red: load curve and blue: relief curve; a elastic region, b region of non-linear deformation, c plastic range, d permanent deformation; F force, s elongation

Specification

- [1] study a beam until plastic deformation
- [2] load on the beam from point load
- [3] fixed and movable support for supporting the beam
- [4] beams of different materials and profiles
- [5] dial gauge for recording the deformation
- [6] storage system for parts
- [7] experimental setup in the SE 112 mounting frame

Technical data**Beams**

- 1x 1000x15x3mm, steel
- 1x 1000x15x3mm, aluminium
- 1x H-profile, 1000x15x15x2mm, aluminium

Load application device

- max. load: $\pm 5000\text{N}$
- max. travel: 100mm

Measuring ranges

- travel: 0...50mm

LxWxH: 1170x480x178mm

Weight: approx. 30kg

Scope of delivery

- 1 set of beams (3 pieces)
- 1 load application device
- 2 supports
- 1 dial gauge
- 1 tension device
- 1 storage system with foam inlay
- 1 set of instructional material

WP 400

Impact test, 25Nm



Learning objectives/experiments

- determine the notched-bar impact work
- determine the notched-bar impact strength
- analyse the fracture surface characteristics
- plot a notched-bar impact work-temperature diagram
- influence of notch shape, material and specimen temperature on the notched-bar impact work

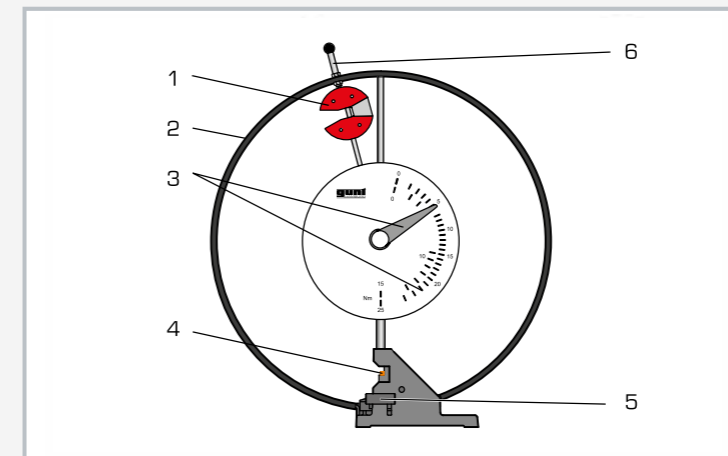

1 hammer with removable additional weights, 2 protective ring, 3 scale with drag pointer, 4 notched bar impact specimen, 5 two-hand trigger and brake, 6 hammer fixing

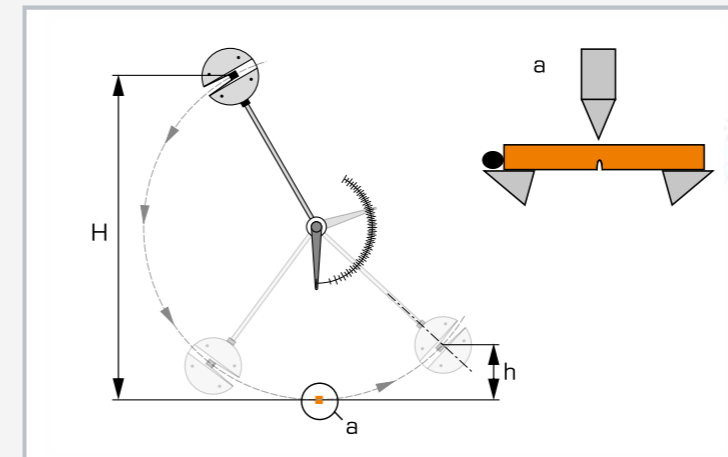

Principle of operation of the Charpy notched bar impact test: H height of fall, h height of rise, a hammer and specimen, plan view

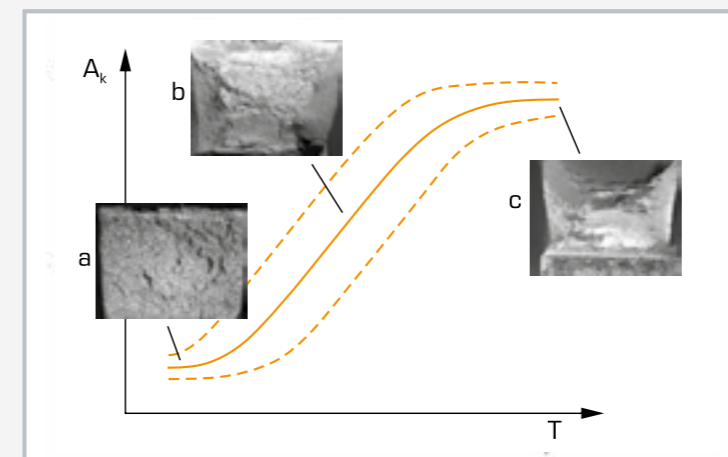

Notched bar impact work-temperature diagram with typical fracture surfaces: average-value curve with distribution area, A_k notched bar impact work, T temperature; a depth position with low-deformation fractures, b transition region [steep front] with mixed fractures, c height position with ductile fractures

Specification

- [1] classic Charpy notched-bar impact test
- [2] pendulum impact tester based on DIN EN ISO 148-1
- [3] hammer mass can be varied by adding or removing weights
- [4] brake to reduce the residual energy
- [5] safe operation thanks to two-hand release of the hammer and protective ring for the operating area
- [6] protective cover WP 400.50 available as an accessory
- [7] scale for displaying the notched-bar impact work
- [8] notched-bar impact specimens according to ISO (U/V notch) and GUNT specimens: automotive steel, tempering steel, structural steel, brass
- [9] system for data acquisition (WP 400.20) available as an option

Technical data

Pendulum impact tester

- work capacity
 - ▶ 15Nm
 - ▶ 25Nm (with extra weights)
- hammer
 - ▶ weight: 2,05kg and 3,42kg (with extra weights)
 - ▶ extra weights: 4x 0,342kg
 - ▶ impact velocity: 3,8m/s
 - ▶ head: 745mm

Supports for specimens

- gap: 40mm

Notched bar impact specimens

- LxW: 10x5mm, 10x10mm
- cross-section at the notch root: 10x8 and 10x5mm

Specimen materials

- automotive steel 9SMn28K
- tempering steel C45k
- structural steel S235JRC+C
- brass CuZn40Pb2

LxWxH: 1000x300x1000mm

Weight: approx. 55kg

Scope of delivery

- 1 experimental unit
- 1 set of weights
- 1 set of specimens (90 pieces)
- 1 set of instructional material

Description

- Charpy notched-bar impact test
- classic method from destructive materials testing for quality control and analysis of the fracture behaviour of metallic materials
- pendulum impact tester based on DIN EN ISO 148-1

In the field of industrial quality control, the impact test is a widely used test method with which to quickly and easily determine characteristics for a material or component analysis.

The WP 400 experimental unit is a solid-pendulum impact tester based on DIN EN ISO 148-1, designed for the Charpy notched-bar impact test. The clean layout and simple operation mean the experimental sequence can be observed in all details and phases.

In the experiment, the hammer attached to a pendulum arm describes an arc. At the lowest point of the hammer path, the hammer transfers part of its kinetic energy to the notched specimen. The specimen is either destroyed or bent by the impact and pushed between the supports.

The notched-bar impact work required to deform the specimen is read directly off a large scale. By using the WP 400.20 system for data acquisition, the measured values can be transferred to a PC where they can be analysed with the software.

In order to vary the output energy, the mass of the hammer can be changed by adding or removing weights.

A brake reduces the residual energy of the hammer on each swing until it reaches zero.

A protective ring ensures the experiments can be conducted safely while also fixing the hammer in place. The hammer is triggered with two hands for safer operation. A protective cover for the WP 400.50 operating area is available as an accessory.

The experimental results allow quality control and an analysis of the fracture behaviour of different metallic materials. Non-metallic specimens can also be used. Specimens with different notch geometries, in different materials and specimen dimensions are included in the scope of delivery.

WP 410

Impact test, 300Nm



Learning objectives/experiments

- determine the notched-bar impact work
- determine the notched-bar impact strength
- analyse the fracture surface characteristics
- plot a notched-bar impact work-temperature diagram
- influence of notch shape, material and specimen temperature on the notched-bar impact work

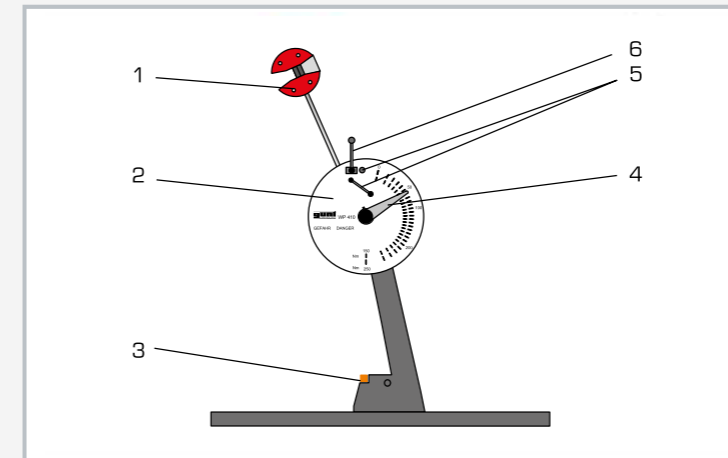

1 hammer with removable extra weights, 2 scale, 3 notched bar impact specimen, 4 drag pointer, 5 two-hand release, 6 brake

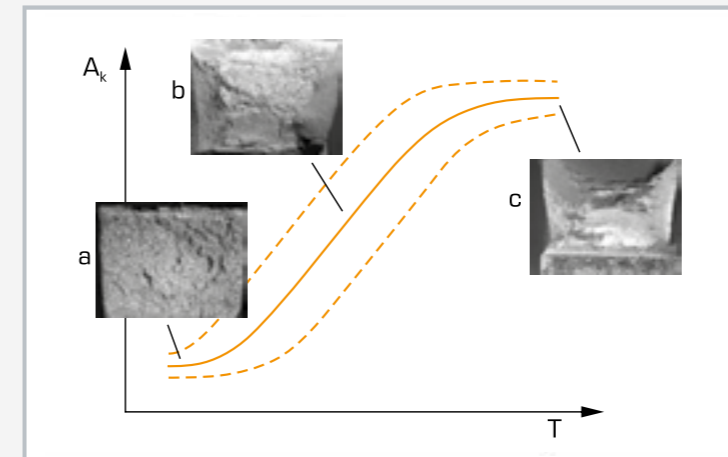

Notched bar impact work-temperature diagram with typical fracture surfaces: average-value curve with distribution area, A_k notched bar impact work, T temperature; a depth position with low-deformation fractures, b transition region (steep front) with mixed fractures, c height position with ductile fractures



Protective cover for pendulum impact tester WP 410.50 available as an accessory

Specification

- [1] Charpy notched-bar impact test with increased work capacity
- [2] pendulum impact tester based on industrial standards / DIN EN ISO 148-1
- [3] hammer mass can be varied by adding or removing weights
- [4] brake to reduce the residual energy
- [5] safe operation thanks to two-handed release of the hammer
- [6] protective cover for pendulum impact tester WP 410.50 available as an accessory
- [7] scale for displaying the notched-bar impact work
- [8] ISO-V notched specimens made of stainless steel, specimens of copper, brass and steel available as accessories
- [9] system for data acquisition (WP 410.20) available as an option

Technical data

Pendulum impact tester

- work capacity
 - ▶ 150Nm
 - ▶ 300Nm (with extra weights)
- hammer
 - ▶ weight: 9,9kg and 19,8kg (with extra weights)
 - ▶ extra weights: 4x 2,475kg
 - ▶ impact velocity: 5,5m/s
 - ▶ pendulum length: 840mm
 - ▶ angle of fall: 150°

Supports for specimens

- gap: 40mm

Notched bar impact specimens (ISO V and ISO U)

- LxW: 10x10mm

Specimen material

- stainless steel 1.4301

230V, 50Hz, 1 phase
230V, 60Hz, 1 phase; 120V, 60Hz, 1 phase
UL/CSA optional
LxWxH: 800x600x1460mm
Weight: approx. 360kg

Scope of delivery

- 1 trainer
- 1 set of weights
- 1 set of specimens (10 pieces)
- 1 set of instructional material

Description

- **Charpy notched-bar impact test with increased work capacity up to 300Nm**
- **pendulum impact tester based on industrial standards / DIN EN ISO 148-1**
- **safe experiments thanks to two-handed release of the hammer and optional protective cage WP 410.50**

In the field of industrial quality control, the impact test is a widely used test method with which to quickly and easily determine characteristics for a material or component analysis.

The WP 410 trainer is a solid-pendulum impact tester based on DIN EN ISO 148-1, designed for the Charpy notched-bar impact test.

The clean layout and simple operation mean the experimental sequence can be observed in all details and phases. The power of the trainer allows tests to be performed on an industrial scale.

In the experiment, the hammer attached to a pendulum arm describes an arc. At the lowest point of the hammer path, the hammer transfers part of its kinetic energy to the notched specimen. The specimen is either destroyed or bent by the impact and pushed between the supports.

The notched-bar impact work required to deform the specimen is read directly off a large scale. By using the WP 410.20 system for data acquisition, the measured values can be transferred to a PC where they can be analysed with the software.

In order to vary the output energy, the mass of the hammer can be changed by adding or removing weights. A brake reduces the residual energy of the hammer.

A protective cover for the operating area allows the experiments to be conducted safely and is available as accessory WP 410.50. The hammer is triggered with two hands for safer operation.

The experimental results allow quality control and an analysis of the fracture behaviour of different metallic materials. Non-metallic specimens can also be used. The scope of delivery includes stainless steel ISO-V notched-bar impact specimens. Specimens made of other materials are available as accessories.

WP 500

Torsion test, 30Nm



Description

- generate the twisting moment by means of a worm gear
- measure the twisting moment by means of a strain-gauge measuring shaft
- incremental encoder for measuring the twisting angle

The torsion test is a destructive testing method that studies the plastic behaviour of materials. In practice, components that are twisted in their application (e.g. screws, shafts, axles, wires and springs) are studied with this test method.

The WP 500 experimental unit allows torsion tests in which specimens are subjected to load until they fracture. The clean layout and simple operation mean the experimental sequence can be observed in all details and phases.

In the experiment, metallic specimens are twisted until they are destroyed by a typical shear fracture.

The twisting moment is applied manually by means of a handwheel and a worm gear. The base plate is torsionally reinforced. A transparent protective cover protects against flying fragments.

The effective twisting moment is measured by means of a moment-measuring shaft fitted with strain gauges and can be read directly on a display. The twisting angle is recorded by an incremental encoder and can also be read. The measured values are transmitted directly to a PC where they can be analysed using the software.

Specimens of different materials and different lengths are included in the scope of delivery. The measuring device can be moved on the rigid frame to adapt to different specimen lengths.

Learning objectives/experiments

- torsion tests with different materials and load until specimen fracture
- determine the twisting strength
- plot the diagram of twisting moment over twisting angle
- influence of
 - ▶ specimen material
 - ▶ specimen cross-section
 - ▶ specimen length

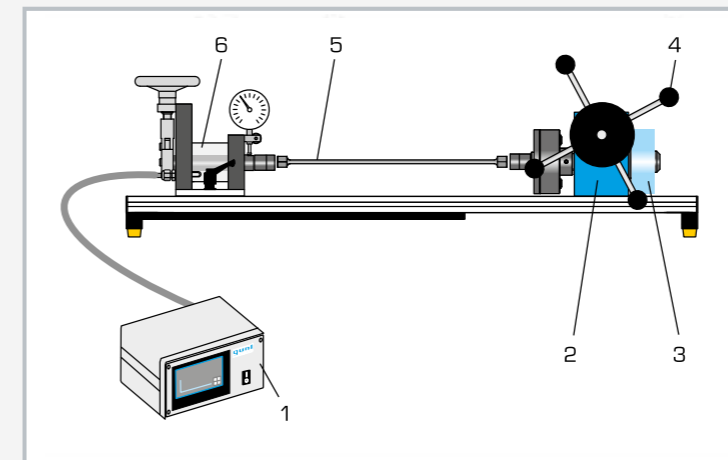

1 measuring amplifier with display, 2 worm gear, 3 incremental encoder, 4 handwheel for twisting moment, 5 specimen, 6 movable measuring device with strain gauge measuring shaft and compensation unit

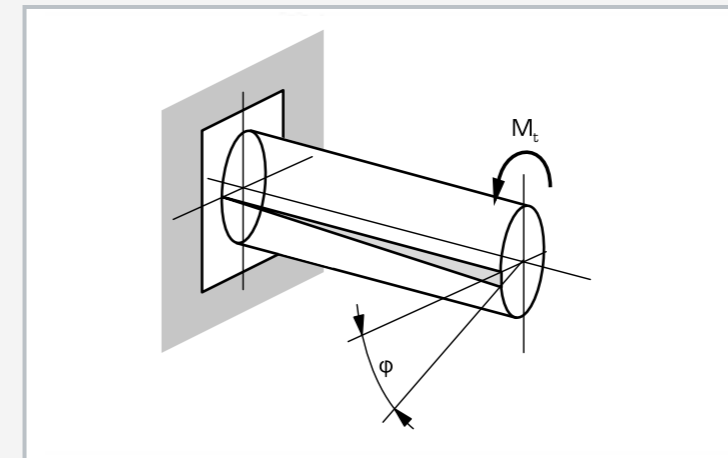

Principle of operation of torsion test: M_t twisting moment, ϕ twisting angle

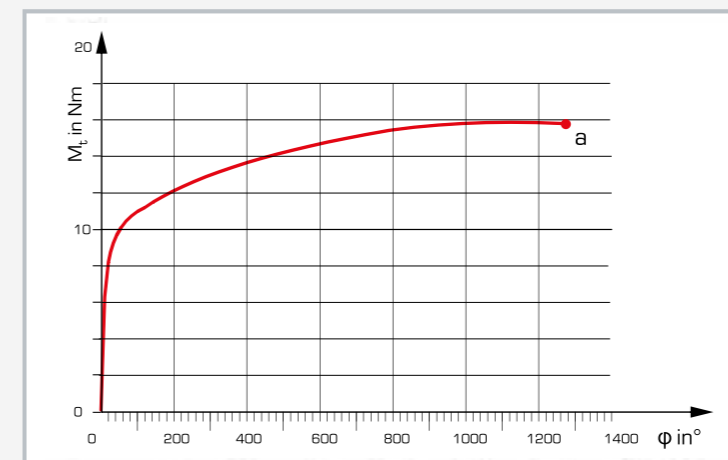

Torsion test of metallic materials to fracture: M_t twisting moment, ϕ twisting angle, a specimen fracture

Specification

- [1] torsion tests with different metallic specimens to fracture
- [2] manual generation of the twisting moment by means of handwheel and worm gear
- [3] specify the input angle via handwheel
- [4] long and short specimens of steel, aluminium, brass
- [5] movable measuring device for different specimen lengths
- [6] measure the test moment by means of strain-gauge measuring shaft and measuring amplifier
- [7] strain-gauge measuring shaft with compensation for inherent deformation
- [8] twisting angle measured by incremental encoder
- [9] electronic measuring amplifier with touch panel to display twisting moment and twisting angle
- [10] GUNT software for data acquisition via USB under Windows 7, 8.1, 10

Technical data

Max. twisting moment: 30Nm

Loading device, worm gear

■ transmission ratio: 1:63

Specimen mount: 2x 17mm, hexagonal

Specimens

- diameter: 6mm
- 4x 75mm, steel
- 4x 75mm, aluminium
- 4x 75mm, brass
- 2x 175mm, steel
- 2x 350mm, steel
- 2x 700mm, steel

Measuring ranges

■ twisting moment: 0...30,0Nm

■ angle of twist: 0...±3200°, resolution: 0,1°

230V, 50Hz, 1 phase

230V, 60Hz, 1 phase; 120V, 60Hz, 1 phase

UL/CSA optional

LxWxH: 1400x700x500mm (experimental unit)

LxWxH: 230x210x120mm (measuring amplifier)

Weight: approx. 43kg (total)

Required for operation

PC with Windows recommended

Scope of delivery

- 1 experimental unit
- 1 measuring amplifier
- 1 set of specimens (18 pieces)
- 1 GUNT software CD + USB cable
- 1 set of instructional material

WP 510

Torsion test 200Nm, motor drive



Description

- measure the test moment by means of strain gauge
- incremental encoder for measuring the twisting angle
- four different deformation rates can be configured
- experiments based on industrial standards

The torsion test is a destructive testing method that studies the plastic behaviour of materials. In practice, components that are twisted in their application (e.g. screws, shafts, axles, wires and springs) are studied with this test method.

The WP 510 experimental unit allows torsion tests in which specimens are subjected to load until they fracture. The clean layout and simple operation mean the experimental sequence can be observed in all details and phases. The power of the experimental unit allows tests to be performed on an industrial scale.

In the experiment, metallic specimens are twisted until they are destroyed by typical shear fracture. The twisting moment is applied from a high-ratio reduction gear motor.

A frequency converter offers four different drive velocities in forward and reverse rotation. The base plate is torsionally reinforced. A transparent protective cover protects against flying fragments.

Specimens of different materials and different lengths are included in the scope of delivery. The measuring device can be moved on the rigid frame to adapt to different specimen lengths.

The effective twisting moment (test moment) is measured by means of a moment-measuring shaft fitted with strain gauges and can be read directly on a display. The twisting angle is recorded by an incremental encoder and can also be read. The microprocessor-based instrumentation is well protected in the housing.

The GUNT software, together with the microprocessor, provides all the advantages of using software to help conduct and analyse the experiments. The unit is connected to the PC via USB.

Learning objectives/experiments

- torsion tests with different materials and load until specimen fracture
- determine the twisting strength
- plot the diagram of twisting moment over twisting angle
- determine the elastic region
- influence of
 - ▶ specimen material
 - ▶ specimen cross-section
 - ▶ specimen length

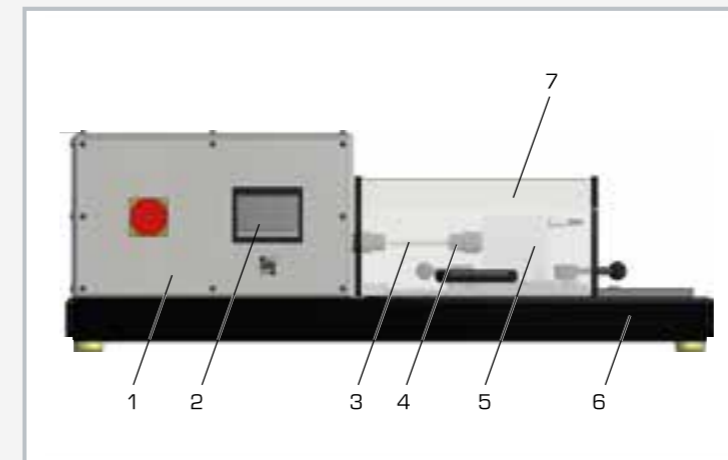

1 drive unit with gear motor, 2 touch panel for operation and displaying measurements, 3 specimen, 4 specimen holder (commercial 19mm socket), 5 quick-release abutment on guide rails with moment measuring device, 6 rigid base plate, 7 transparent protection

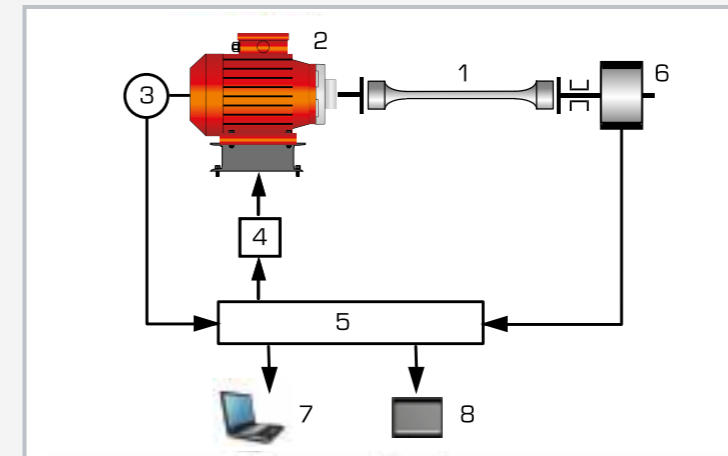

1 specimen, 2 gear motor, 3 incremental encoder, 4 frequency converter, 5 microprocessor, 6 strain gauge measuring shaft, 7 PC, 8 touch panel

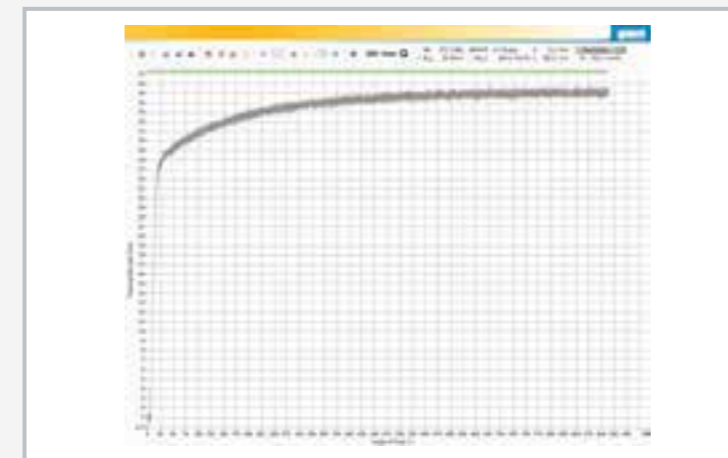

Software screenshot: twisting moment over twisting angle

Specification

- [1] motor-supported torsion tests with different metallic specimens to fracture
- [2] generate the twisting moment by means of worm gear motor; adjustable torsion rates, forward and reverse
- [3] worm gear motor, speed controlled by frequency converter
- [4] specimens: steel, aluminium, brass
- [5] measure the test moment by means of strain-gauge measuring shaft
- [6] twisting angle measured by incremental encoder
- [7] measured values displayed and controlled via touch panel
- [8] microprocessor-based measuring technology
- [9] GUNT software for data acquisition via USB under Windows 7, 8.1, 10

Technical data

Worm gear motor

- max. twisting moment: 200Nm
- torsional velocities: 50, 100, 200, 500°/min
- frequency converter with 4 fixed speeds
- motor output: 0,12kW, forward and reverse

Specimens

- diameter: 9mm, length: 100mm
- 3x steel
- 3x aluminium
- 3x brass
- specimen holder: 2x19mm, hexagonal
- possible specimen lengths: max. 300mm

Measuring ranges

- twisting moment: 0...199,9Nm
- angle of twist: 0...±3200°, resolution: 0,1°

230V, 50Hz, 1 phase
230V, 60Hz, 1 phase; 120V, 60Hz, 1 phase
UL/CSA optional
LxWxH: 1120x550x380mm
Weight: approx. 95kg

Required for operation

PC with Windows

Scope of delivery

- 1 experimental unit
- 3 set of specimens (9 pieces)
- 1 GUNT software CD + USB cable
- 1 set of instructional material

WP 140

Fatigue strength test



Description

- different specimens show the influence of notching and surface quality
- continuous adjustment of the load amplitude
- automatically shuts down when the specimen fractures

Moving components and machine parts are often exposed to periodically fluctuating loads. Even if the dynamic load is far below the static load capacity, this load can lead to fracture of the component after a long time because of material fatigue. The fatigue strength and design strength of components are determined in fatigue strength tests or endurance tests.

The WP 140 trainer demonstrates the basic principles of fatigue strength testing and the creation of a Wöhler diagram. The clean layout and simple operation mean the experimental sequence can be observed in all details and phases. In the experiment, a cantilever-mounted and rotating cylindrical specimen is subjected to a single force. The load on the specimen corresponds to a cantilever bending beam. The specimen is subjected to a pure reverse bending stress and breaks after a certain number of load cycles because of material fatigue.

The necessary force is generated in the load application device by means of a spring balance and a movable support. The load amplitude can be adjusted continuously using the preload of the spring balance by means of a threaded spindle. An electronic counter registers the number of load cycles and displays it digitally. The impulse for the counter is provided by an inductive proximity switch on the motor coupling. The counter can also be used to measure the speed.

When the specimen breaks, the stop switch stops the electric motor automatically. A protective cover protects against flying fragments.

Specimens with various fillet radii are included in the scope of delivery to demonstrate the notching effect and the influence of the surfaces.

By using the WP 140.20 system for data acquisition, the measured values can be transferred to a PC where they can be analysed with the software.

Learning objectives/experiments

- fatigue strength of bars under reverse bending stress
- influence of different fillet radii and surface qualities on the fatigue strength
- Wöhler diagram



1 protective cover, 2 electric motor, 3 switch box, 4 tool, 5 specimens, 6 bearing, 7 clamped specimen, 8 load application device with spring balance and hand wheel

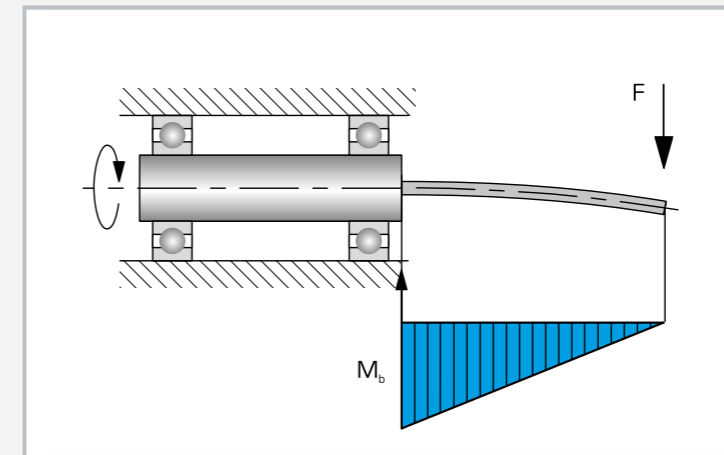

Functional principle of a fatigue strength test: cantilever mounted rotating specimen, loaded with a single force; F force, M_b bending moment

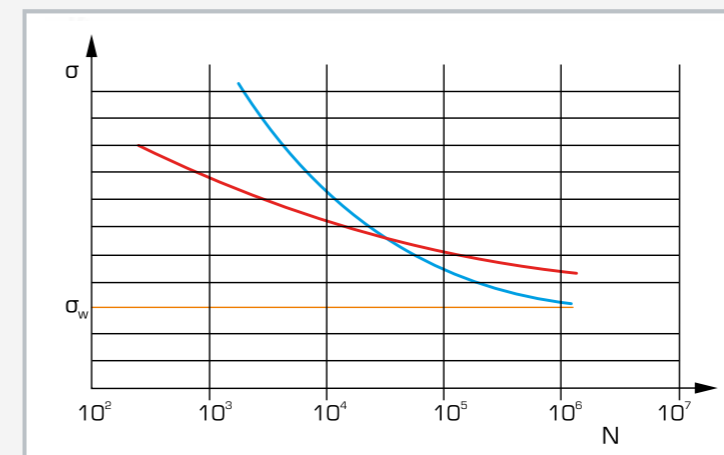

Wöhler diagram for two different materials N: number of load cycles, σ : stress load on the specimen
With increasing number of cycles, the permissible load of a material asymptotically approaches the fatigue strength σ_w .

Specification

- [1] basic principles of fatigue strength testing
- [2] driven by electric motor
- [3] automatically shuts down when the specimen fractures
- [4] load application device with sliding movable support, threaded spindle with hand wheel, spring balance
- [5] steel cylindrical specimens, various fillet radii
- [6] speed measured by contactless inductive speed sensor or electronic counter for load cycles
- [7] digital counter display
- [8] protective cover for safe operation
- [9] system for data acquisition (WP 140.20) available as an option

Technical data

Electric motor
 ■ speed: 2800 min^{-1}
 ■ power: $0,37 \text{ kW}$

Load force
 ■ $0 \dots 300 \text{ N}$

Electronic load counter
 ■ 8-digit
 ■ switchable to indicate speed

Specimens
 ■ material: steel Ck35
 ■ 3 different fillet radii

230V, 50Hz, 1 phase
 230V, 60Hz, 1 phase; 120V, 60Hz, 1 phase
 UL/CSA optional
 LxWxH: $840 \times 410 \times 600 \text{ mm}$
 Weight: approx. 31 kg

Scope of delivery

- 1 experimental unit
- 1 set of specimens (9 pieces)
- 1 set of instructional material

WP 600

Creep rupture test

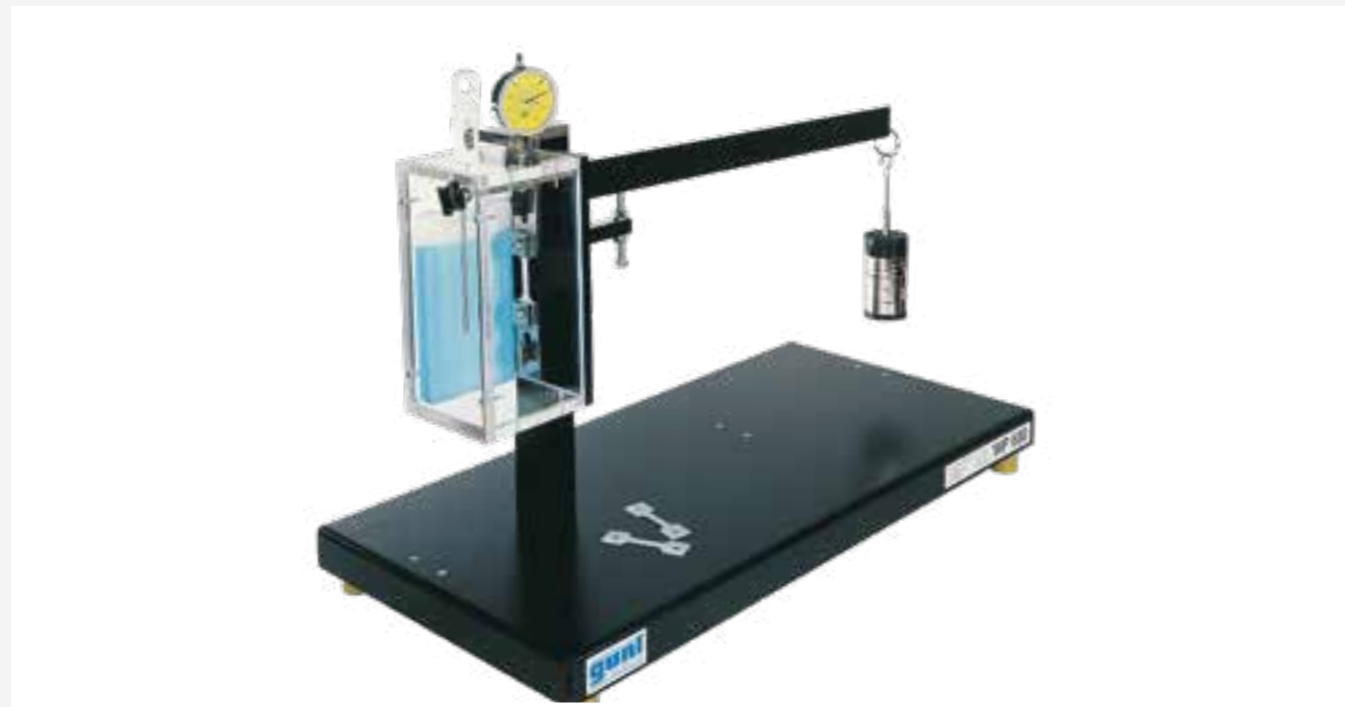

Description

- typical phenomena of creep processes
- experiments at or below room temperature are possible

Components that are subjected to long-term constant loads deform plastically. This material behaviour is called creep. The creep rupture test is a destructive test method for determining the material behaviour (creep) at constant test temperature (room temperature and below) and after prolonged exposure to a constant load.

The WP 600 experimental unit demonstrates typical phenomena such as phases of different creep rates or temperature-dependent creep behaviour. The clean layout and simple operation mean the experimental sequence can be observed in all details and phases. Lead and plastic specimens are used in order to achieve acceptable creep rates at room temperature.

Experiments can also be conducted below room temperature by means of a transparent temperature-controlled box with storage elements.

In the experiment, the specimen is subjected to a constant tensile load at a given, constant temperature. The tensile load is generated by a lever and stepped weights. The specimen holders are equipped with knife-edge bearings to avoid bending stresses on the specimen. An adjustable stop protects the dial gauge at fracture of the specimen and prevents the loads impacting the experimental unit.

The elongation of the specimen over time is recorded by a dial gauge and a stopwatch and represented in a strain-time diagram as the so-called creep curve.

Learning objectives/experiments

- creep in specimens of various materials
- record a strain-time diagram (creep curve)
- influence of temperature and load on the creep
- load and recovery in plastics

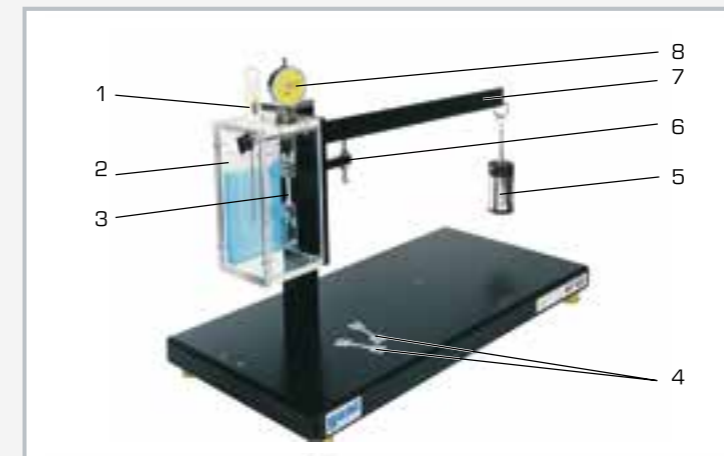

1 thermometer for temperature-controlled box, 2 storage element for cooling the specimen, 3 clamped specimen, 4 specimens, 5 weight, 6 adjustable stop for the lever, 7 lever, 8 dial gauge

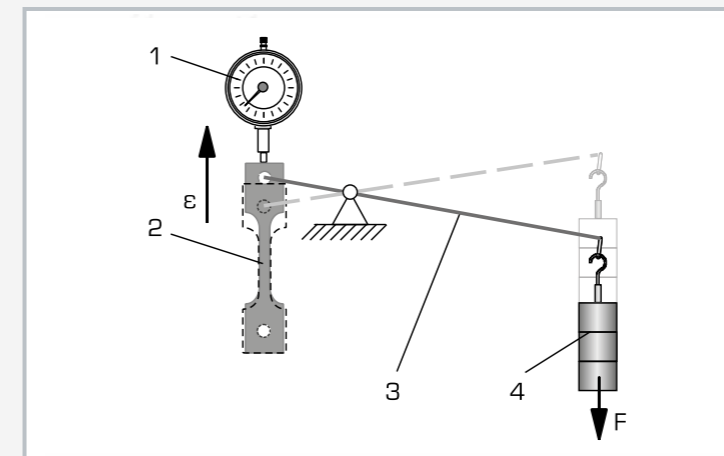

Principle of operation of the creep rupture test: 1 dial gauge, 2 specimen, 3 lever for load transfer, 4 weight; F force, ε strain

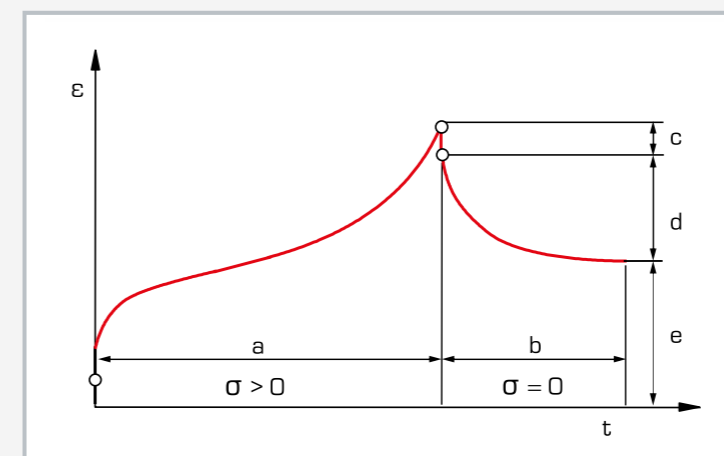

Strain-time diagram (creep curve) of plastic: a load, b recovery, c elastic recovery, d plastic recovery, e permanent deformation, ε strain, σ stress, t time

Specification

- [1] investigation of creep behaviour of different materials in creep rupture test
- [2] constant load on the specimen via lever arm and stepped weights
- [3] flat lead and plastic (PE) specimens
- [4] experiments at or below room temperature are possible
- [5] transparent temperature-controlled box with storage elements for cooling the specimen
- [6] dial gauge for determining the elongation
- [7] stopwatch to record time

Technical data

Specimens

- LxW: 25x5mm, thickness 2mm
- 10x lead
- 10x plastic (PE)

Weights

- 1x 1N (hanger)
- 2x 5N
- 3x 2N
- 3x 1N
- 2x 0,5N

Measuring ranges

- tension: 5...25N/mm²
- travel: 0...10mm, graduation: 0,01mm
- temperature: -50...300°C

LxWxH: 700x350x510mm

Weight: approx. 23kg

Scope of delivery

- 1 experimental unit
- 1 set of specimens (20 pieces)
- 1 set of weights
- 1 stopwatch
- 1 temperature-controlled box with 2 storage elements and 1 thermometer
- 1 set of instructional material

Tribology and corrosion

Tribology

Tribology is the science and technology of interacting surfaces in relative motion. The application of tribology in engineering is used to study friction, wear and lubrication. These studies extend to all areas of development, engineering design, production and maintenance of mechanical motion systems. Wear processes are analysed by means of a so-called tribological system and are described by "systemic" loss variables. A tribological system

contains all elements such as components and substances that are involved in a tribological load, as well as their properties. Material components such as body, counter body, intermediate substance and ambient medium form the system structure. The input variables and disturbance variables are summarised as collective stresses.

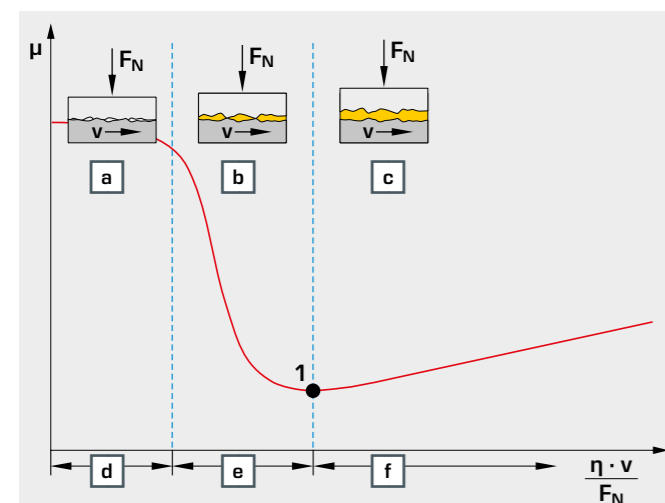
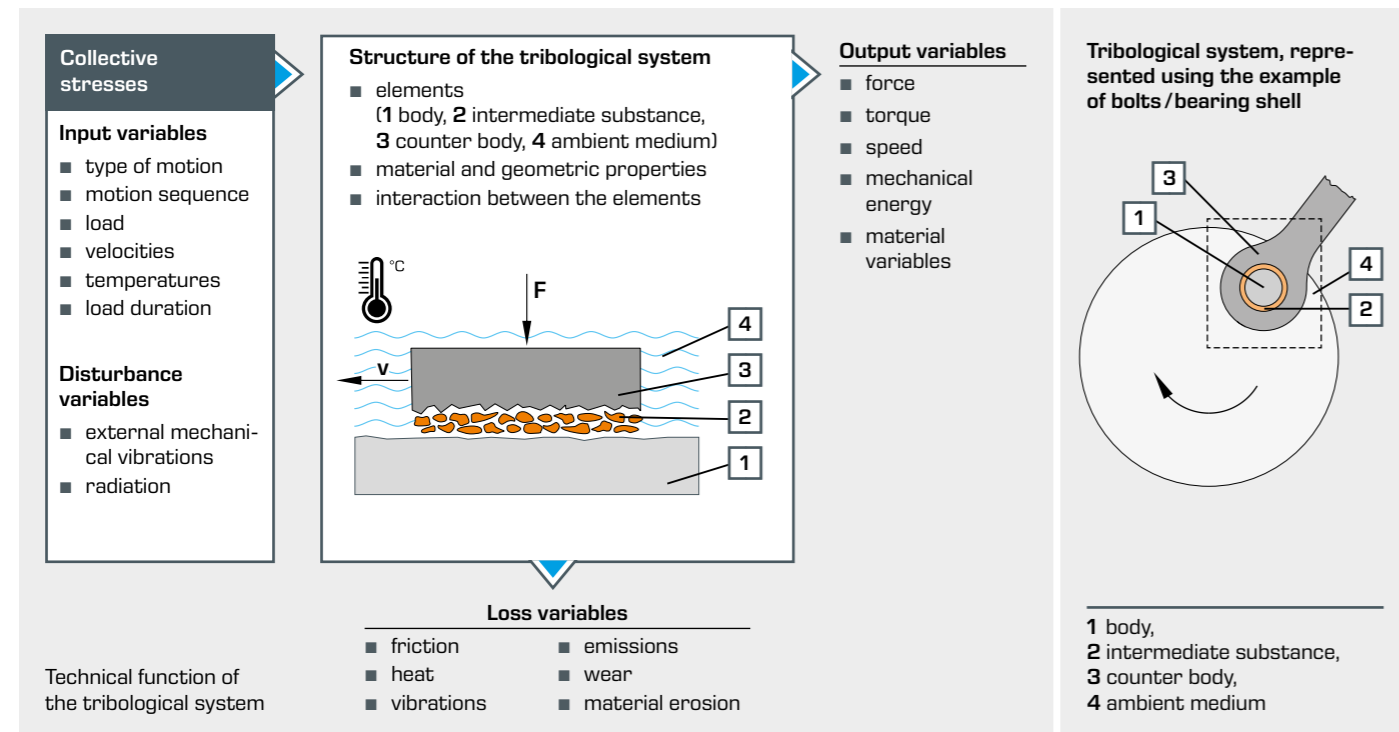

Stribeck curve for hydrodynamic friction

μ coefficient of friction, n speed, F_N load, v velocity, η viscosity, **a** dry friction, **b** mixed friction, **c** fluid friction, **d** boundary lubrication, **e** thin-film lubrication, **f** fluid lubrication, **1** release point

In the analysis of tribological systems, loss variables such as coefficient of friction, frictional forces and frictional vibrations are determined by suitable measuring methods. The change of an input variable or disturbance variable can change the friction and wear behaviour significantly. Experiments are required in order to investigate dependencies of loss variables.

The Stribeck curve gives a good overview of occurring friction states, such as in slide bearings. The relationships between coefficient of friction, friction pressure and bearing force are shown clearly. With increasing velocity, the lubricant film thickness increases and the regions of dry friction, mixed friction and fluid friction, in which the surfaces are completely separated by the lubricating film, are passed through in sequence.

The transition from mixed friction to fluid friction is known as the release point. The lowest wear occurs in the region of fluid friction.

Corrosion

Corrosion refers to the reaction of a metallic material to its environment, which causes a measurable change in the material. This can lead to impairment of the function of a metal component or a whole system.

The form of the material changes due to corrosion

Surface erosion, uniform erosion of the workpiece surface

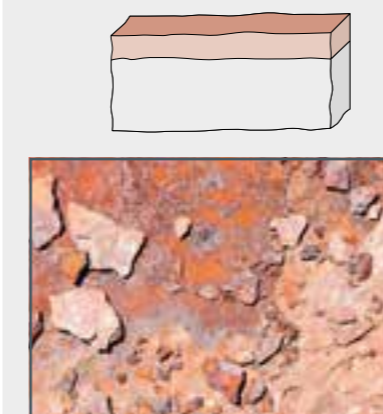

Pitting corrosion, crater-shaped or pinhole-like depressions that undermine the surface

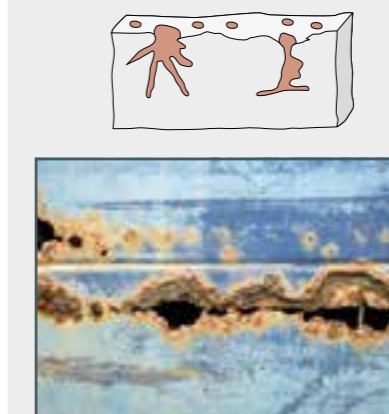
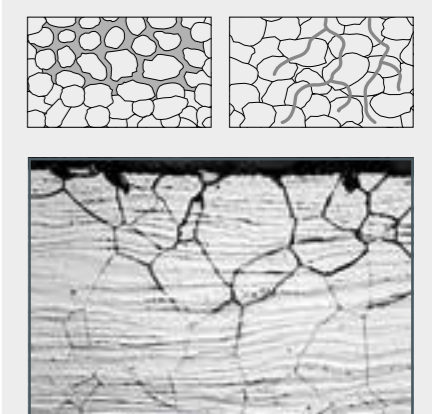

Figure left and below: intergranular corrosion along the grain boundaries.

Figure right: transgranular corrosion, transverse through the grains



Processes during corrosion

The environmental conditions of the material are significant for corrosion. Essentially, these are gases from the surrounding atmosphere and liquids. Solutions can be electrolytes

(ion-conducting liquids). In metals, corrosion is caused primarily by electrochemical or chemical processes.

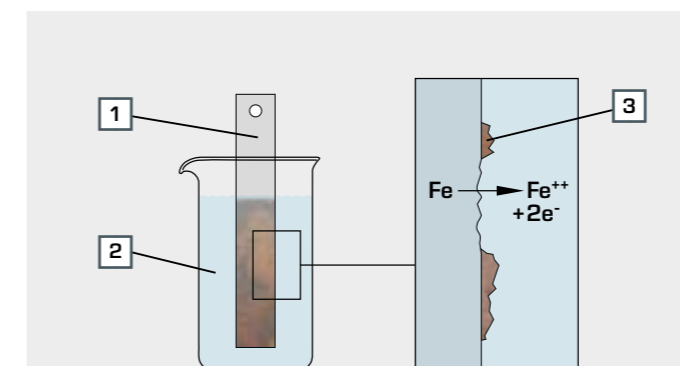

Oxygen corrosion: a direct electron exchange takes place between iron and oxygen-enriched water. The iron bonds with the oxygen to form iron oxide.

1 electrode (iron Fe), 2 electrolyte enriched with oxygen (water), 3 iron oxide, Fe^{++} iron ion, e^- free electron

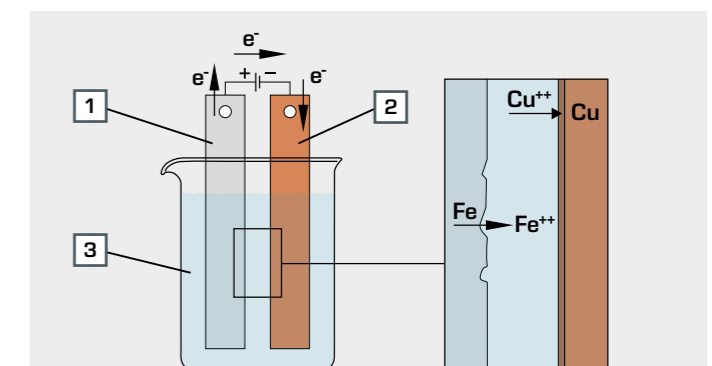

Electrochemical corrosion occurs through the formation of galvanic elements. If two different metals come into contact, an electrical current flows in the presence of an electrolyte. This dissolves base metal. More or less current flows depending on the metals present, and destruction takes place.

1 anode (iron Fe), 2 cathode (copper Cu), 3 electrolyte (copper sulphate $CuSO_4$), Cu^{++} copper ions, e^- electron, Fe^{++} iron ion

TM 260

Drive unit for tribological investigations



Description

- base module for studying various cases of sliding and rolling friction
- contact force by means of weights and lever
- electronic measurement of the frictional force between friction partners

Tribology studies friction, wear and lubrication. Friction occurs when two solids are in contact with each other and their movement is impeded. If material is lost progressively during this process, it is referred to as wear. Lubricants are used to minimise friction and wear.

The TM 260 drive unit, together with the experimental units TM 260.01 to TM 260.06, offer a complete course with a series of experiments to study tribological phenomena. Various rolling and sliding cases can be demonstrated in the classroom or studied in the laboratory. The parameters of a tribological system are recorded and analysed. A comprehensive range of friction pairings makes it possible, among other things, to represent how the frictional force is independent of the contact area.

The TM 260 units comprise a frame on which the drive unit is mounted together with an experimental unit and a display and control unit. Quick-action chucks make it quick and easy to assemble. The drive unit has a pivotable motor block bearing. This allows the drive shaft to be installed horizontally or vertically. The speed of the DC motor is continuously adjustable and is detected by means of an incremental encoder. The frictional forces are measured by a force sensor in each experimental unit.

The display and control unit shows frictional force and speed, the latter of which can be adjusted continuously.

The following experiments can be conducted: Rolling friction in friction wheels (TM 260.01), Elasto-hydrodynamic behaviour (TM 260.02), Dynamic friction in a pin on a disk (TM 260.03), Frictional vibrations (TM 260.04), Dynamic friction in a cylindrical pin on a roller (TM 260.05), Pressure distribution in journal bearings (TM 260.06).

Learning objectives/experiments

- together with the experimental units TM 260.01 to TM 260.06
 - ▶ rolling friction of two disks with slip
 - ▶ elasto-hydrodynamic behaviour (EHD theory) in rolling friction of a sphere against a flat surface
 - ▶ wear test: pin against disk
 - ▶ wear test: friction wheel experiment
 - ▶ frictional vibrations and slip-stick phenomenon
 - ▶ pressure distribution in the journal bearing

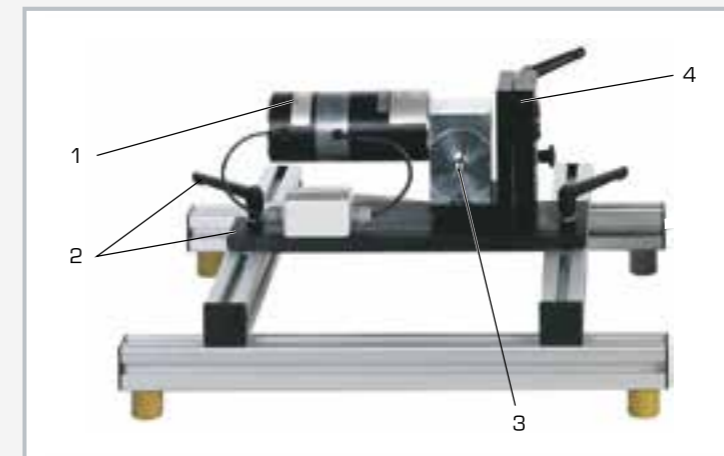

1 motor and gear, 2 quick-action chuck, 3 drive shaft, 4 pivotable drive



1 TM 260.03 experimental unit studies a tribological system, consisting of a pin and disk, which slide against each other, 2 TM 260 drive unit

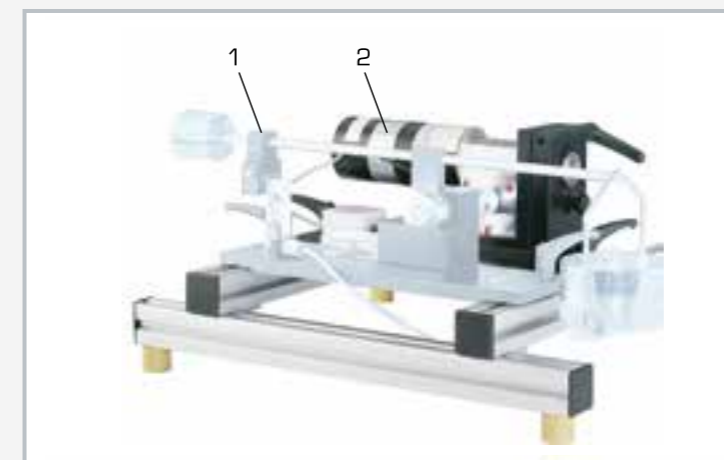

1 TM 260.05 experimental unit studies a tribological system, consisting of a cylindrical pin and a roller, which slide against each other (point contact), 2 TM 260 drive unit

Specification

- [1] base module with drive unit and display and control unit for studying tribological phenomena
- [2] horizontal or vertical position of the drive shaft by means of pivotable motor block
- [3] various experimental units available as accessories
- [4] drive unit and experimental units secured by quick-action chucks
- [5] drive unit comprising DC motor with worm gear
- [6] speed of the DC motor is continuously adjustable
- [7] speed measured by incremental encoder
- [8] frictional force measured by force sensor
- [9] force and speed displayed on display and control unit

Technical data

DC motor

- rated speed: 3000min⁻¹
- torque: 18,5Nm

Worm gear: ratio 15:1

- operating speed: 0...200min⁻¹, electronically controlled

Measuring ranges

- force: 0...50N
- speed: 0...200min⁻¹

230V, 50Hz, 1 phase

230V, 60Hz, 1 phase; 120V, 60Hz, 1 phase

UL/CSA optional

LxWxH: 500x450x280mm (base module)

Weight: approx. 10kg

LxWxH: 360x330x170mm (display and control unit)

Weight: approx. 6kg

Scope of delivery

- 1 base module
- 1 display and control unit
- 1 set of cables
- 1 set of instructional material

TM 260.01

Rolling friction in friction wheels



The illustration shows TM 260.01 on the TM 260 frame.

Description

- frictional forces between two rolling friction wheels
- how slip affects the frictional force
- use of different lubricants possible

In bearing and drive technology, dynamic friction occurs at the sliding and rolling points, which leads to power losses in the technical systems. Dynamic friction is differentiated into sliding, rolling and spinning friction. In dynamic friction, there is relative translation between the two bodies. Rolling friction occurs when two bodies roll on each other without sliding. In rolling friction, the rolling motion is superposed with a smaller sliding friction, known as slip. Rolling friction is therefore a combination of rolling and dynamic friction.

The tribological system in TM 260.01 allows a clear representation of the rolling friction and an analysis of the frictional forces. The experimental unit comprises two friction wheels, pairing the materials aluminium and rubber at the contact points.

The slip between the friction wheels is kept constant at 4% by a gear unit. The contact force can be adjusted gradually up to a maximum of 80 N by means of a lever. The experimental unit includes a tank that supplies lubricant. Different lubrication conditions can be studied, such as dry friction, water or oil lubrication.

The TM 260 drive unit is required in order to conduct experiments. The experimental unit is mounted quickly and easily on the frame of the drive unit with quick-action chucks. The driving wheel is driven by a clampable coupling between drive unit and gear unit. The display and control unit of the drive unit shows frictional force and speed and allows the continuous adjustment of the speed.

The frictional force and the coefficient of friction can be determined in experiments. The frictional forces are measured by a force sensor.

Learning objectives/experiments

- together with the drive unit
 - ▶ determine the frictional forces as a function of load, lubrication and operating speed
 - ▶ how slip affects the frictional force
 - ▶ determine the coefficients of friction

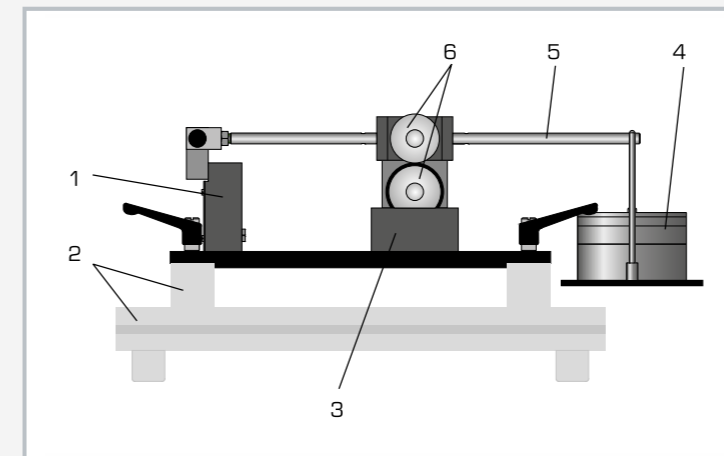

1 force sensor, 2 frame of TM 260, 3 tank for lubricant, 4 weight, 5 load application device lever, 6 friction wheels

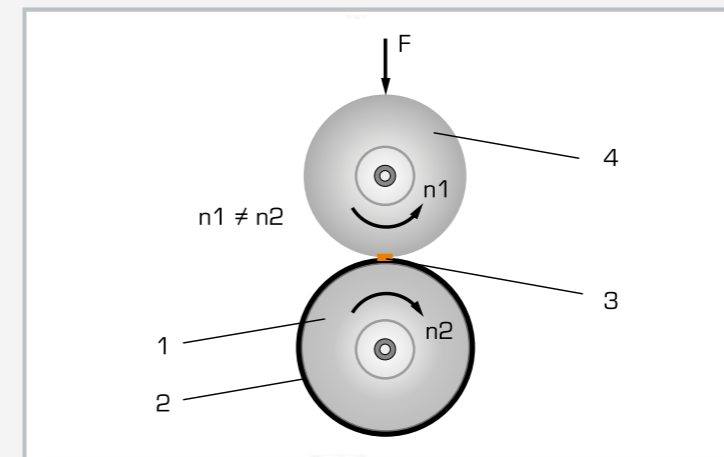

Tribological system using the example of friction wheels pairing aluminium and rubber: 1 driving friction wheel as main body, 2 rubber ring, 3 lubricant as intermediate substance, 4 driven wheel as counter body, F force, n speed

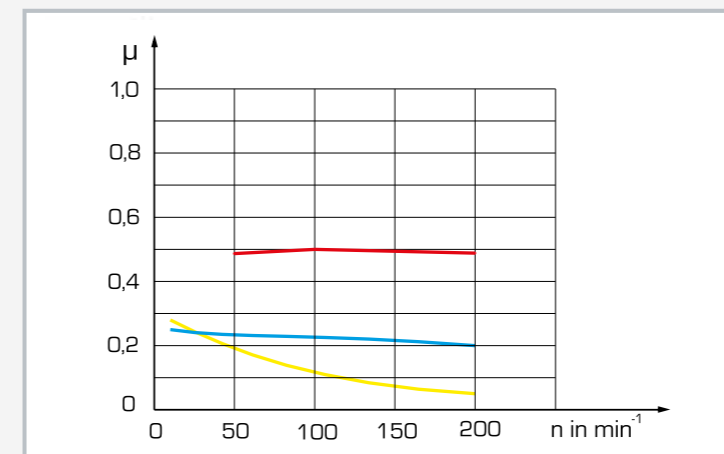

Coefficients of friction for different lubrication at constant load; μ coefficient of friction, n speed, red: dry friction, blue: water lubrication, yellow: oil lubrication

Specification

- [1] frictional forces in two rolling friction wheels
- [2] quick and easy assembly of the experimental unit on the frame of the drive unit
- [3] driving wheel is driven by a clampable coupling between drive unit and gear unit
- [4] slip between friction wheels kept constant at 4% by means of gear unit
- [5] load on the friction wheels via lever arm and stepped weights
- [6] friction wheels materials pair: aluminium/rubber
- [7] use of different lubricants
- [8] frictional force measured by force sensor
- [9] displays of force and speed and speed adjustment on the drive unit

Technical data

Load application device

- max. load: 80N
- lever arm ratio: 2:1

Friction wheels

- $\varnothing=49\text{mm}$
- $\varnothing=45\text{mm}$, incl. rubber ring

Gear ratio

- i: 0,96, slip approx. 23%

Force sensor for frictional force

- 0...50N

Weights

- 1x 5N (hanger)
- 1x 5N
- 1x 10N
- 1x 20N

LxWxH: 480x250x150mm

Weight: approx. 7kg

Scope of delivery

- 1 experimental unit
- 2 friction wheels
- 1 set of weights
- 1 set of instructional material

TM 260.02

Elasto-hydrodynamic behaviour



Learning objectives/experiments

- together with the drive unit
 - ▶ determine the thickness of the lubricating film at the contact point of a sphere with a plane surface – compare with theoretical value
 - ▶ study the effect of load and speed on the thickness of the lubricating film

Description

- elasto-hydrodynamic behaviour between the sphere and rotating-glass-plate friction pair
- investigation of the thickness and shape of the lubricating film

Elasto-hydrodynamic lubrication occurs in roller bearings, gear wheels and cam followers, whose contact surfaces are subjected to high loads. These surfaces are elastically deformed because of high contact pressures. The theory of elasto-hydrodynamics (EHD theory) takes into consideration the elastic deformation of the bodies in contact with each other and provides a basis for calculating the influence of lubrication on damage to gears and roller bearings.

The tribological system in TM 260.02 allows a clear representation of the elasto-hydrodynamic behaviour of lubricating film layers.

To do this, the lubricating film between a sphere and a glass plate is determined and studied using a reflected-light microscope. The experimental unit contains a rotating glass plate and a steel sphere as the friction pair. The steel sphere is pressed against the glass plate from underneath. The contact force between the friction partners can be adjusted continuously by means of a lever. A lubricating film is located between the sphere and glass plate at the contact point. The glass plate is plane-parallel and dielectric coated. The surface of the hardened steel ball is polished. The reflected-light microscope stands on an adjustable xy cross table and has a focus drive.

The TM 260 drive unit is required in order to conduct experiments. The experimental unit is mounted quickly and easily on the frame of the drive unit with quick-action chucks.

The glass plate is driven by a clampable coupling between drive unit and gear unit. The display and control unit of the drive unit shows contact force and speed and allows the continuous adjustment of the speed.

In the experiment, light waves from the reflected-light microscope pass through the glass plate and the lubricating film and are reflected by the surface of the steel sphere. The light waves are refracted in the lubricating film, making colour interference fringes visible. The wavelength of light increases or decreases with the variable thickness of the lubricating film. The thickness of the lubricating film is determined visually by means of the colour of the interference fringes created. The contact force is measured by a force sensor.

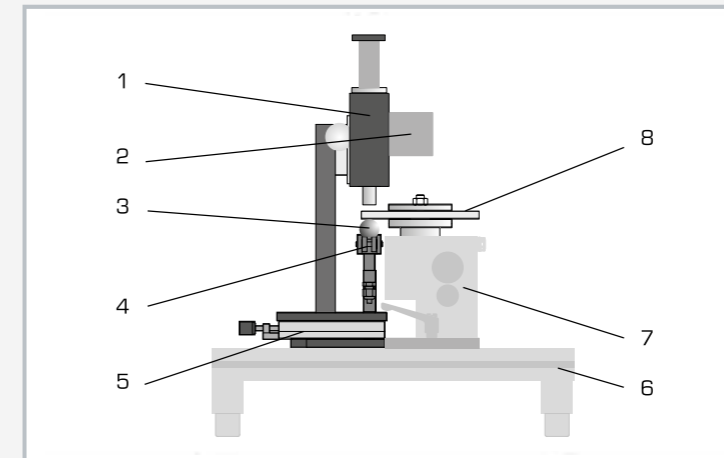

1 reflected light microscope, 2 halogen lamp, 3 steel sphere, 4 load application device, 5 cross table, 6 frame of TM 260, 7 drive unit from TM 260, 8 glass plate

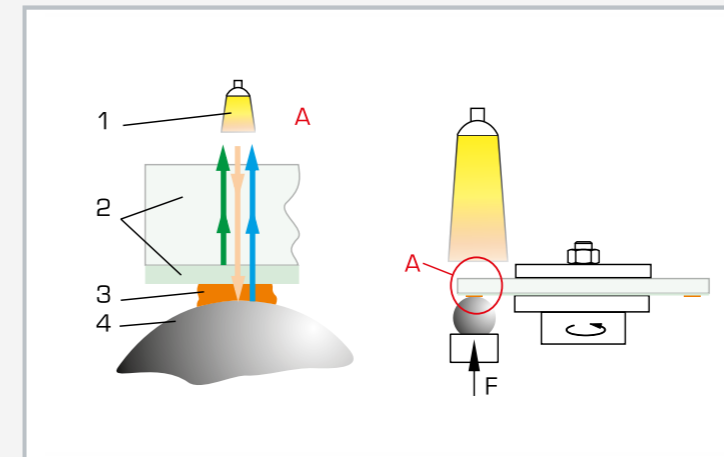

Determine the thickness of the lubricating film by optical interference: 1 halogen lamp, 2 glass plate with dielectric coating, 3 lubricating film, 4 steel sphere; arrows orange: incident light, green: dielectric coating reflects 30% of the light, blue: steel sphere reflects the remaining light

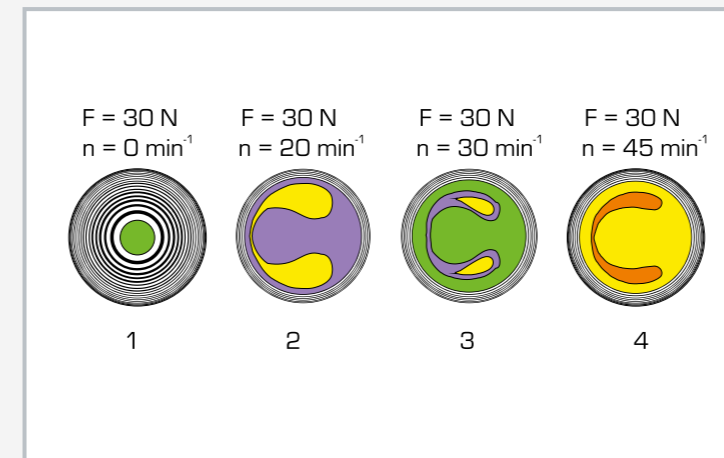

Effect of lubricating film thickness on speed: 1 static case, 2 to 4 increase in lubricating film width (lubricating oil ISO VG 100)

Specification

- [1] elasto-hydrodynamic behaviour of a lubricating film layer between sphere and rotating glass plate
- [2] quick and easy assembly of the experimental unit on the frame of the drive unit
- [3] determine the thickness of the lubricating film by optical interference
- [4] glass plate is driven by a clampable coupling between drive unit and gear unit
- [5] hardened steel sphere, polished
- [6] rotating plane-parallel glass plate with dielectric coating
- [7] continuous load on the sphere via lever arm
- [8] load measured by force sensor
- [9] displays of force and speed and speed adjustment on the drive unit

Technical data

Load application device

- max. load: 150N
- lever arm ratio: 3:1

Sphere

- diameter: 25,4mm
- hardened steel, polished

Glass plate

- diameter: 150mm, plane-parallel
- coating: BK 7, dielectric, R=30%

Microscope

- magnification: x50
- halogen lamp: 10W

Force sensor: 0..50N

LxWxH: 350x250x550mm

Weight: approx. 8kg

Scope of delivery

- 1 experimental unit
- 1 sphere
- 1 glass plate
- 1 set of instructional material

TM 260.03

Dynamic friction in pin - disk

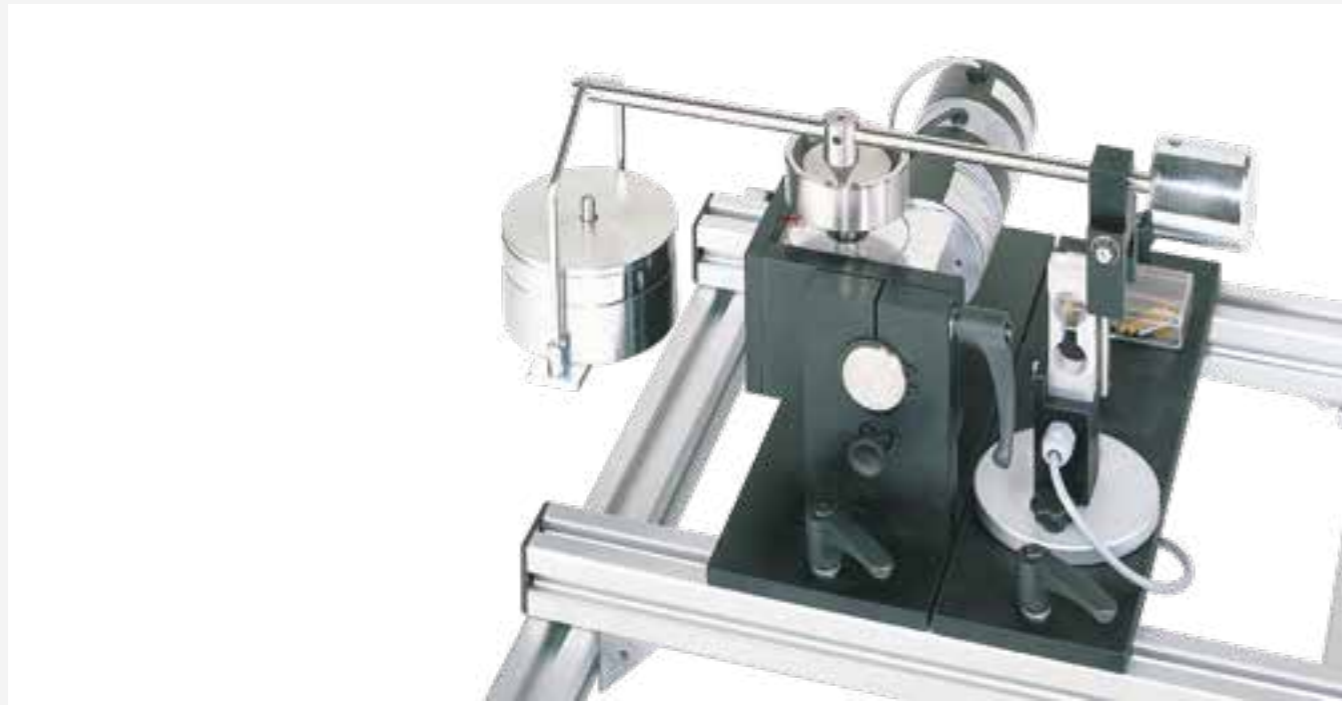

Description

- frictional forces between two sliding friction pairs
- investigation of wear
- use of different lubricants possible

In bearing and drive technology, dynamic friction occurs at the sliding and rolling points, which leads to power losses in the technical systems. Dynamic friction is differentiated into sliding, rolling and spinning friction. In dynamic friction, there is relative translation between the two bodies.

The tribological system in TM 260.03 allows a clear representation of the dynamic friction and an analysis of the frictional forces. The experimental unit contains a fixed pin that is pressed axially against a rotating disk as the friction pair. The contact force between the friction partners can be adjusted gradually up to a maximum of 80 N by means of a lever. The rotating disk is enclosed by an open cup that can be filled with different lubricants for the experiments.

Different lubrication conditions can be studied, such as dry friction, water or oil lubrication. Pins made of different materials are included in the scope of delivery to study different friction pairings.

The TM 260 drive unit is required in order to conduct experiments. The experimental unit is mounted quickly and easily on the frame of the drive unit with quick-action chucks. The disk is driven by a clampable coupling between drive unit and gear unit. The display and control unit of the drive unit shows frictional force and speed and allows the continuous adjustment of the speed.

The frictional force and the coefficient of friction can be determined in experiments. The frictional forces are measured by a force sensor. The wear can be determined precisely by measuring the change (reduction) in length of the pin.

Learning objectives/experiments

- together with the drive unit
 - ▶ frictional forces in different friction pairs and loads
 - ▶ frictional forces with different lubrication
 - ▶ frictional forces at different relative speeds of the friction partners
 - ▶ wear under different friction parameters and lubrication conditions

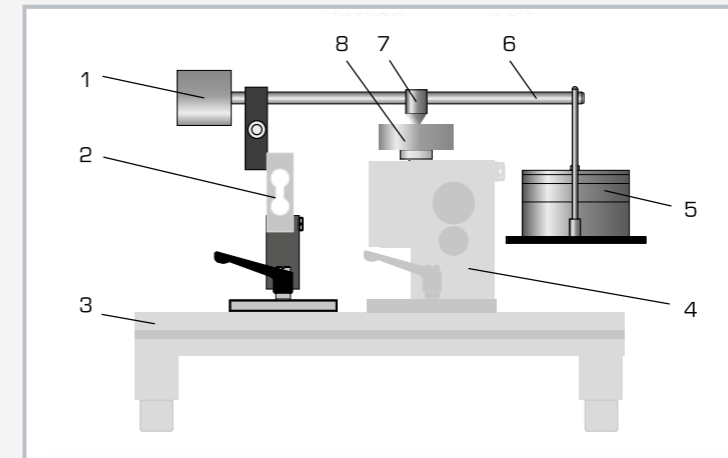

1 counterweight, 2 force sensor, 3 frame of TM 260, 4 drive unit from TM 260, 5 weight, 6 load application device lever, 7 pin, 8 disk

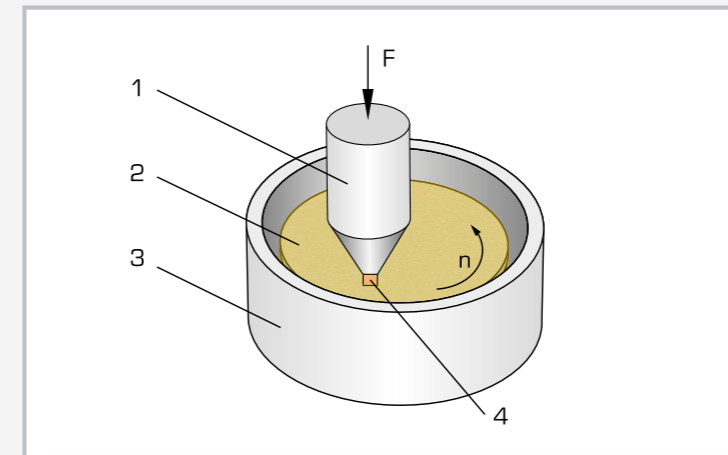

Tribological system pin and disk: 1 pin as counter body, 2 rotating disk as main body, 3 cup with lubricant as intermediate substance, 4 contact area; F force, n speed

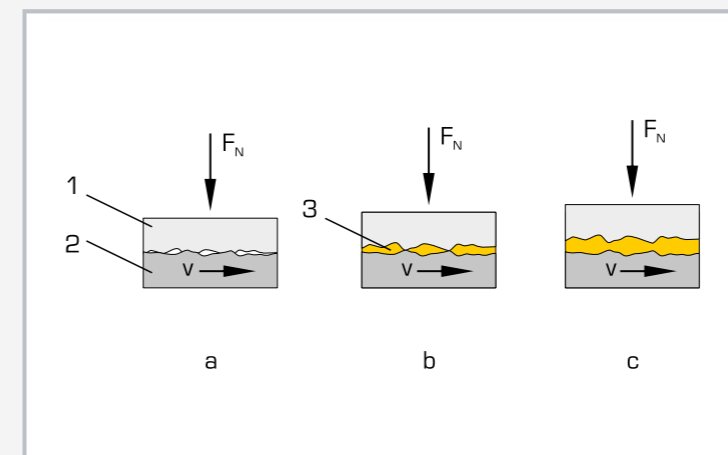

Effect of the lubricating film on friction: 1 pin, 2 disk, 3 lubricant; a dry friction, b mixed friction, c fluid friction; F_N force, v velocity

Specification

- [1] frictional forces in pin and disk, which slide against each other, disk subjected to axial load
- [2] quick and easy assembly of the experimental unit on the frame of the drive unit
- [3] disk is driven by a clampable coupling between drive unit and gear unit
- [4] fixed pin made of different materials: aluminium, brass or steel
- [5] rotating disk made of hardened and ground stainless steel
- [6] load on the pin via lever arm and stepped weights
- [7] use of different lubricants, e.g. water or oil
- [8] frictional force measured by force sensor
- [9] displays of force and speed and speed adjustment on the drive unit

Technical data

Load application device

- max. load: 80N
- lever arm ratio: 2:1

Disk

- $\varnothing=50\text{mm}$
- hardened stainless steel, ground

Pin, $\varnothing \times H$: 4x25mm

- 3x aluminium
- 6x brass
- 6x steel

Force sensor for frictional force

- 0...50N

Weights

- 1x 5N (hanger)
- 1x 20N
- 1x 10N
- 1x 5N

LxWxH: 350x430x230mm

Weight: approx. 8kg

Scope of delivery

- 1 experimental unit
- 1 disk
- 1 set of pins
- 1 set of weights
- 1 set of instructional material

TM 260.04

Frictional vibrations



Description

- slip-stick phenomenon at the transition from static to dynamic friction
- friction rings of different materials for the study of different friction pairings

Friction is the resistance of a body against movement on a base. Static friction means that a body remains at rest under the action of a force. If a limit value is exceeded, the body begins to move on the base, resulting in dynamic friction. Self-excited friction oscillations, also known as slip-stick phenomenon, occur if the static friction is significantly higher than the dynamic friction.

The tribological system in TM 260.04 allows a clear demonstration of the transition from static to dynamic friction and the occurrence of friction oscillations. The experimental unit contains a rotating stainless-steel disk and a loosely fitting friction ring as the friction pair. The contact force between the friction partners can be adjusted gradually up to a maximum of 40 N by means of weights.

A tension spring prevents the friction ring from rotating. The necessary holding force is measured by a force sensor.

The TM 260 drive unit is required in order to conduct experiments. The experimental unit is mounted quickly and easily on the frame of the drive unit with quick-action chucks. The disk is driven by a clampable coupling between drive unit and gear unit. The display and control unit of the drive unit shows frictional force and speed and allows the continuous adjustment of the speed.

The frictional force and the coefficient of friction can be determined in experiments. The frictional forces are measured by a force sensor. Friction rings made of different materials are included in the scope of delivery to study different friction pairings.

Learning objectives/experiments

- together with the drive unit
 - ▶ observation of the transition from static to dynamic friction
 - ▶ influence of lubrication on slip-stick phenomenon
 - ▶ influence of the force between the friction partners on the slip-stick phenomenon
 - ▶ influence of the relative velocity of the friction partners on the slip-stick phenomenon

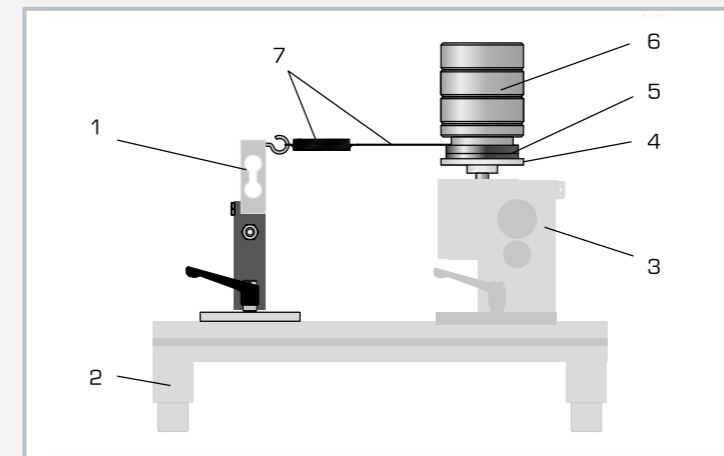

1 force sensor, 2 frame of TM 260, 3 drive unit from TM 260, 4 rotating disk, 5 friction ring, 6 weight, 7 spring and cable

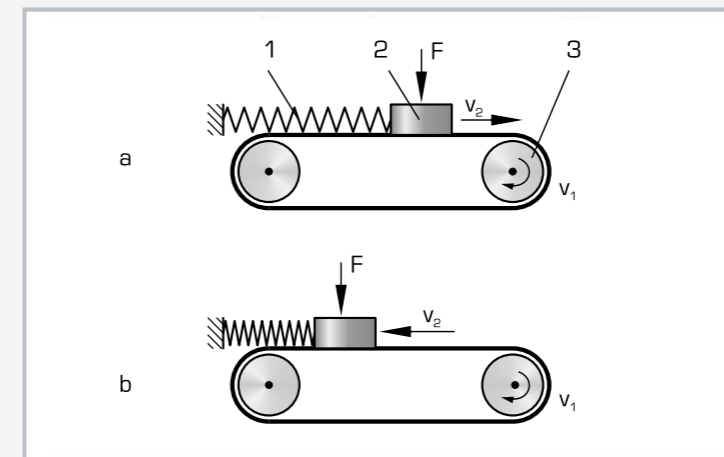

Friction oscillations (Slip-stick phenomenon): 1 spring, 2 body, 3 drive; F force, v velocity, a static, b dynamic

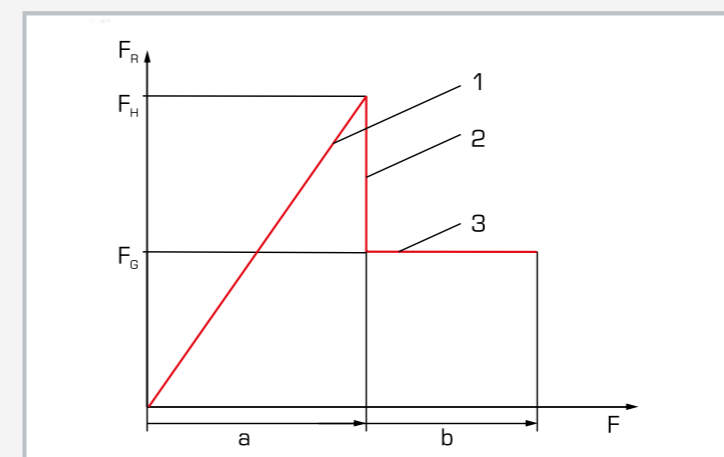

Frictional force at static and dynamic friction: 1 static friction, 2 slide limit, 3 dynamic friction, F_R frictional force, F traction, F_H static frictional force, F_G dynamic frictional force, a rest state, b motion

Specification

- [1] friction oscillations at static and dynamic friction
- [2] quick and easy assembly of the experimental unit on the frame of the drive unit
- [3] rotating stainless steel disk
- [4] disk is driven by a clampable coupling between drive unit and gear unit
- [5] friction ring of different materials: stainless steel, brass or plastic (PA)
- [6] friction pair subject to load by stepped weights
- [7] frictional force measured by force sensor
- [8] displays of force and speed and speed adjustment on the drive unit

Technical data

Disk

- Ø: 60mm
- stainless steel

Friction ring

- outer diameter: 80mm
- inner diameter: 50mm
- 1x stainless steel
- 1x brass
- 1x plastic (PA)

Force sensor for frictional force

- 0...50N

Weights

- 1x 5N
- 3x 10N

Weight: approx. 7kg

Scope of delivery

- 1 experimental unit
- 1 disk
- 1 friction ring
- 1 spring
- 1 set of weights
- 1 set of instructional material

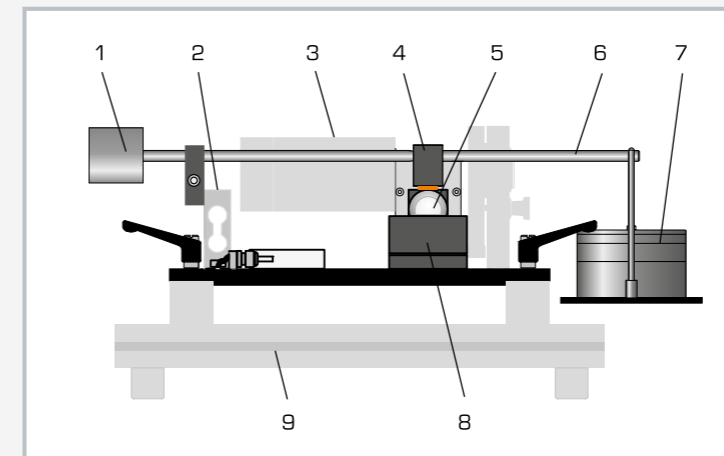
TM 260.05**Dynamic friction in cylindrical pin - roller**

1 counterweight, 2 force sensor, 3 drive unit from TM 260, 4 sliding holder with cylindrical pin, 5 roller, 6 load application device lever, 7 weight, 8 tank for lubricant, 9 frame from base module TM 260

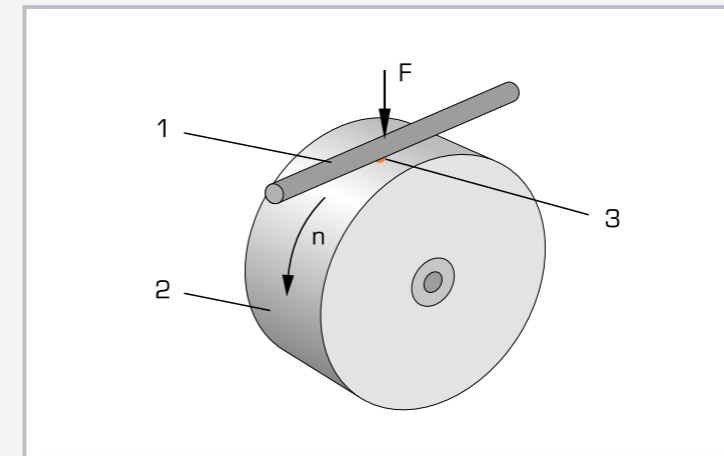

Tribological system of cylindrical pin and roller (point contact): 1 fixed cylindrical pin as counter body, 2 rotating roller as main body, 3 lubricant as intermediate substance; F force, n speed

Specification

- [1] frictional forces in cylindrical pin and roller that slide on each other (point contact)
- [2] quick and easy assembly of the experimental unit on the frame of the drive unit
- [3] rotating roller made of hardened and ground stainless steel
- [4] roller is driven by a clampable coupling between drive unit and gear unit
- [5] fixed cylindrical pin made of different materials: aluminium, brass or steel
- [6] load on the cylindrical pin via lever arm and stepped weights
- [7] use of different lubricants, e.g. oil or water
- [8] frictional force measured by force sensor
- [9] displays of force and speed and speed adjustment on the drive unit

Technical data**Load application device**

- max. load: 80N
- lever arm ratio: 2:1

Roller

- $\varnothing=40\text{mm}$
- hardened stainless steel, ground

Cylindrical pin, $\varnothing \times H$: 10x20mm

- 3x aluminium
- 6x brass
- 6x steel

Force sensor for frictional force

- 0...50N

Weights

- 1x 5N (hanger)
- 1x 20N
- 1x 10N
- 1x 5N

LxWxH: 570x100x120mm

Weight: approx. 8kg

Scope of delivery

- 1 experimental unit
- 1 roller
- 1 set of cylindrical pins
- 1 set of weights
- 1 set of instructional material

Description

- frictional forces between two sliding friction pairs
- investigation of wear
- use of different lubricants possible

In bearing and drive technology, dynamic friction occurs at the sliding and rolling points, which leads to power losses in the technical systems. Dynamic friction is differentiated into sliding, rolling and spinning friction. In dynamic friction, there is relative translation between the two bodies.

The tribological system in TM 260.05 allows a clear representation of the dynamic friction and an analysis of the frictional forces. The experimental unit contains a fixed cylindrical pin that is pressed radially against a rotating roller as the friction pair. There is point contact between the friction partners. The contact force between the friction partners can be adjusted gradually up to a maximum of 80 N by means of a lever. The experimental unit includes a tank that supplies lubricant.

Different lubrication conditions can be studied, such as dry friction, water or oil lubrication. Cylindrical pins made of different materials are included in the scope of delivery to study different friction pairings.

The TM 260 drive unit is required in order to conduct experiments. The experimental unit is mounted quickly and easily on the frame of the drive unit with quick-action chucks. The roller is driven by a clampable coupling between drive unit and gear unit. The display and control unit of the drive unit shows frictional force and speed and allows the continuous adjustment of the speed.

The frictional force and the coefficient of friction can be determined in experiments. The frictional forces are measured by a force sensor.

Learning objectives/experiments

- together with the drive unit
 - ▶ frictional forces in different friction pairs and loads
 - ▶ frictional forces with different lubrication
 - ▶ frictional forces at different relative speeds of the friction partners
 - ▶ wear under different friction parameters

TM 260.06**Pressure distribution in journal bearings****Learning objectives/experiments**

- together with the drive unit
 - ▶ pressure distribution in the journal bearing depending on speed
 - ▶ pressure distribution in the journal bearing depending on load or bearing gap width
 - ▶ stability limit as a function of the gap width

Description

- depiction of radial pressure distribution in a journal bearing at different bearing gap widths
- bearing housing made of transparent plastic

The field of tribology covers all forms of friction. Dry, mixed and fluid friction all occur in journal bearings. Under operating conditions there is completely distinct fluid friction, so that the shaft and bearing shell are separated by a supporting lubricating film. The supporting function of the lubricating film can be described by the pressure distribution in the bearing gap.

The experimental unit TM 260.06 is used to visualise the radial pressure profile in the journal bearing with hydrodynamic lubrication.

To this end, the experimental unit contains an open bearing shell which only encloses a shaft half way and which simulates the journal bearing. The bearing shell is secured to two spring plates in such a way that it can be moved. Unlike real hydrodynamic journal bearings, the gap width can be adjusted via the radially moveable bearing housing by means of the spring plates and a micrometer screw.

The TM 260 drive unit is required in order to conduct experiments. The experimental unit is quickly and easily mounted on the frame of the drive unit with quick-action chucks. The shaft is driven by a clampable coupling between drive unit and gear unit. The display and control unit of the drive unit shows frictional force and speed and allows the continuous adjustment of the speed.

There are 13 measuring points around the circumference of the bearing shell to measure the pressure. The pressures are read off from a 13 tube manometers using the height of each column of liquid. The lubricant is supplied via an oil pan. The bearing shell is transparent, allowing close observation of the experiment.

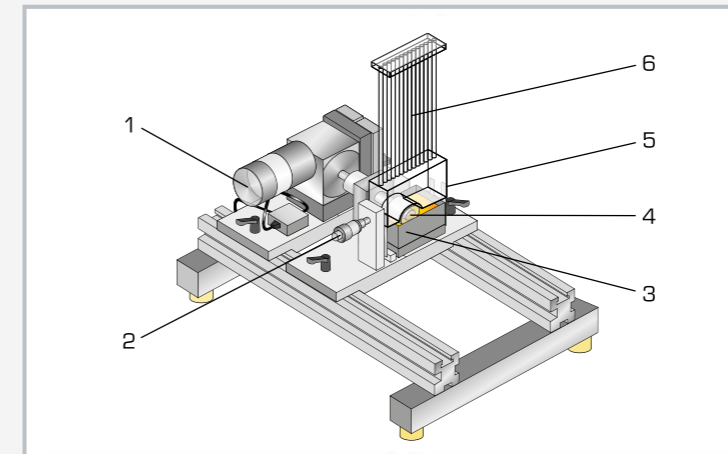

1 TM 260 base module, 2 bearing gap width adjustment, 3 oil pan, 4 shaft, 5 bearing housing with bearing shell, 6 tube manometers

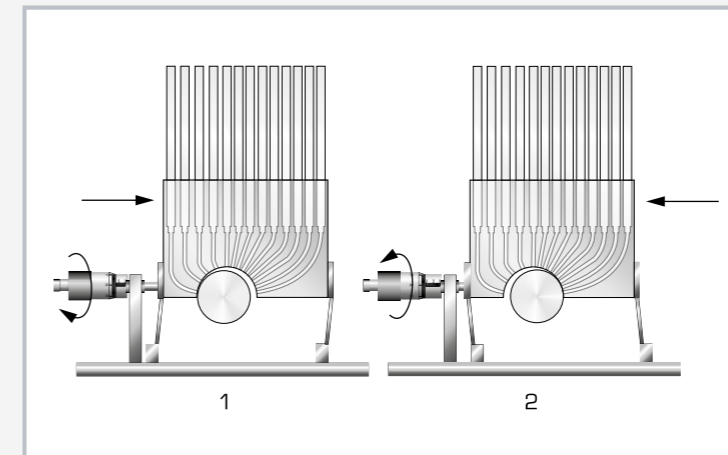

How adjustment of the bearing shell (bearing gap width) works: 1 bearing shell in right-hand position, 2 bearing shell in left-hand position

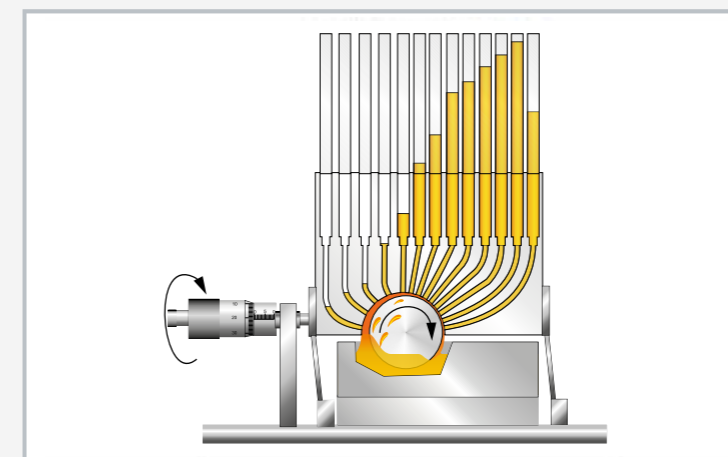

Pressure distribution over the bearing shell; pressure increases as the bearing gap decreases

Specification

- [1] demonstration and visualisation of the pressure distribution in a journal bearing with hydrodynamic lubrication
- [2] quick and easy assembly of the experimental unit on the frame of the drive unit
- [3] roller is driven by a clampable coupling between drive unit and gear unit
- [4] bearing housing is completely transparent
- [5] moveable bearing housing, adjustable bearing gap
- [6] 13 radial pressure measuring points on the bearing shell
- [7] radial pressure distribution indicated with 13 tube manometers
- [8] TM 260 base module required for operation

Technical data**Shaft**

- diameter: 50mm
- length: 50mm
- material: stainless steel

Bearing shell

- diameter: 52,5mm
- bearing gap adjustable from: 0...2,5mm

Adjustment mechanism for bearing shell

- graduation: 0,01mm

Oil

- ISO viscosity grade: VG 32

Measuring ranges

- pressure: 360mm oil column
- speed: 0...200min⁻¹

LxWxH: 350x150x450mm

Weight: approx. 4kg

Scope of delivery

- 1 experimental unit
- 1 oil (0,5L)
- 1 set of instructional material

TM 232

Bearing friction



Learning objectives/experiments

- determine the frictional moment in slide bearings with various friction pairs
- determine the frictional moment of a rolling bearing
- comparison of slide and rolling bearings
- basic experiments on rotational dynamics

Description

- **friction in slide bearings and roller bearings**
- **interchangeable bearing shells for slide bearings of different materials**

Bearings can be classified as slide bearings or roller bearings depending on the nature of their motion. In slide bearings, there is a sliding motion between the bearing and the supported component. In roller bearings, there is both sliding motion and rolling motion between rolling bodies and the supported component. Sliding motion is undesirable in roller bearings, e.g. between rolling body and cage. The bearing force is transferred in the roller bearing by means of rolling.

In both types of bearings—the slide bearing and the roller bearing—frictional forces occur during operation, which oppose resistance to the movement.

The TM 232 experimental unit allows investigations of friction on slide bearings with different bearing shells and on roller bearings. A shaft with a cable drum and flywheel is mounted on a base plate. The weight of the heavy flywheel generates bearing forces. A moment is applied by means of weights, which is equal to the friction moment at the start of the rotation. Replaceable bearing shells are used as slide bearings.

The coefficients of friction are determined in experiments. Bearing shells made of different materials are included in the scope of delivery in order to study different friction pairings. The bearing friction is very low when using the roller bearing. In this case, the flywheel can be used for basic experiments on rotational dynamics.

The experimental unit is designed to be fixed to a wall. The parts of the experiment are clearly laid out and securely housed in a storage system.

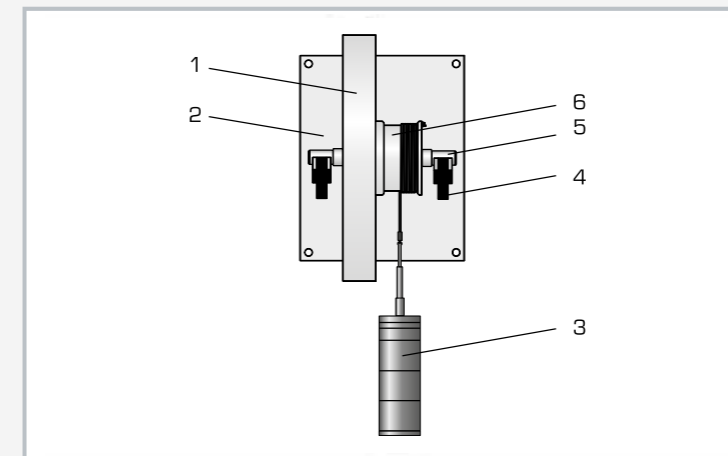

1 flywheel, 2 base plate, 3 weight, 4 bearing seat, 5 shaft, 6 cable drum

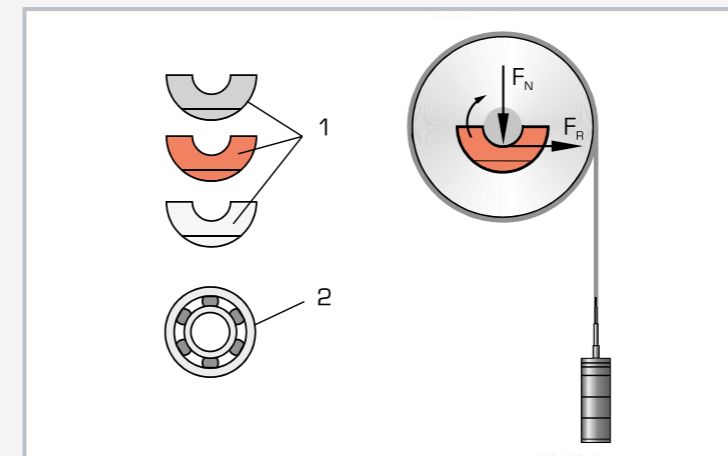

1 interchangeable bearing shells of cast iron, red bronze and plastic (PTFE), 2 roller bearing; F_N normal force, F_R frictional force

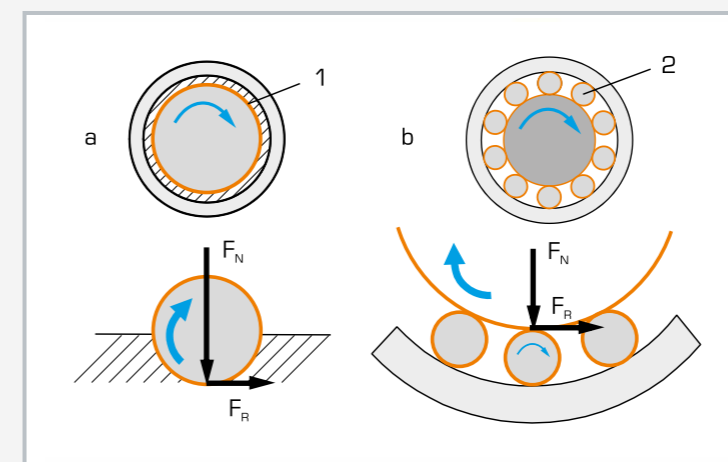

a dynamic friction in the slide bearing, 1 sliding surface
b dynamic friction and rolling friction in the rolling bearing, 2 roller bearing; F_N normal force, F_R frictional force

Specification

- [1] comparison of dynamic friction and rolling friction
- [2] experiments on rotational dynamics are possible
- [3] bearing shells of different materials as slide bearings
- [4] steel flywheel, galvanised
- [5] drive via cable drum and weights
- [6] storage system for parts
- [7] bracket for wall mounting

Technical data

Bearing shells as slide bearing, half-shells

- GG-25
- red bronze
- PTFE (Teflon)

Deep-groove ball bearing

- type 6203

Shaft bearing journal

- $\varnothing=17\text{mm}$

Flywheel

- $\varnothing=300\text{mm}$
- weight: 22,2kg

Weights

- 1x 1N (hanger)
- 5x 1N
- 1x 2N
- 3x 5N

Base plate

- LxW: 250x200mm

LxWxH: 200x330x300mm

Weight: approx. 30kg

LxWxH: 290x140x130mm (storage system)

Scope of delivery

- 1 experimental unit
- 6 bearing shells
- 2 roller bearings
- 1 set of weights
- 1 storage system
- 1 set of instructional material

TM 282

Friction in journal bearings



Description

- fundamentals of hydrodynamic lubrication
- friction states under different operating conditions
- electronic speed control and digital display of speed and lubricant temperature

There are many factors that influence the friction states in a hydrodynamic journal bearing. Speed, load and viscosity of the lubricant used are focused on in particular.

TM 282 allows the study of various factors that influence friction. The journal bearing comprises an electrically driven shaft journal that rotates in a freely movable bearing housing. The movement of the oil in the bearing can be observed.

The applied load is transmitted to the bearing housing through a load application device and can be varied by means of weights. The frictional moment is determined by means of a movable weight that balances the moment on a balance beam. The journal is driven by an electric motor at a speed that can be adjusted by a frequency converter. The temperature (and therefore the viscosity) of the lubricant is recorded by a temperature sensor in the bearing shell and shown on a screen on the display and control unit. The lubricant is supplied via a wick oiler that applies the oil via two grooves in the bearing bush. The accumulated leakage oil is collected in a collecting tank.

Learning objectives/experiments

- develop an understanding of technological relationships of hydrodynamic lubrication by experimentation
- frictional moment in a journal bearing as a function of
 - ▶ speed
 - ▶ bearing load
 - ▶ lubricant and lubricant temperature

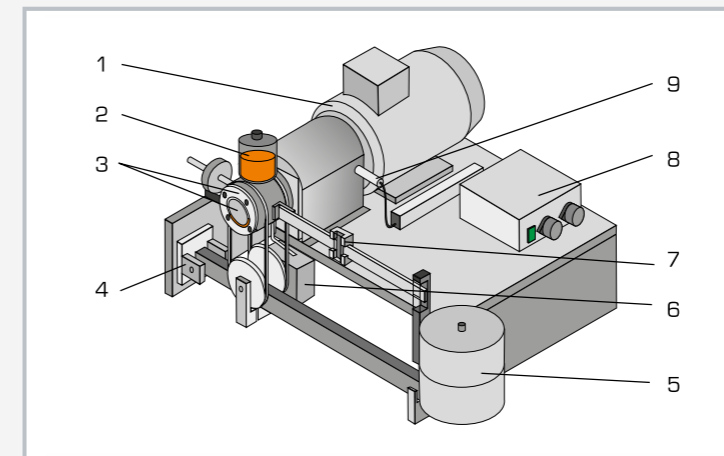

1 motor, 2 drip oiler, 3 journal bearing housing with shaft journal, 4 fixed support for loading lever, 5 weights, 6 tank for leak oil, 7 sliding weight to measure frictional moment, 8 switch box, 9 speed sensor

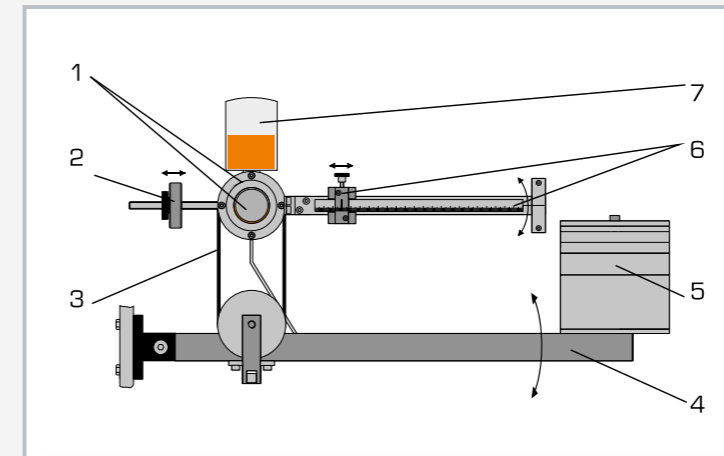

1 journal bearing housing with shaft journal, 2 tare weight, 3 belt to transfer force to the bearing housing, 4 loading lever, 5 weights, 6 measuring lever with scale and sliding weight, 7 drip oiler

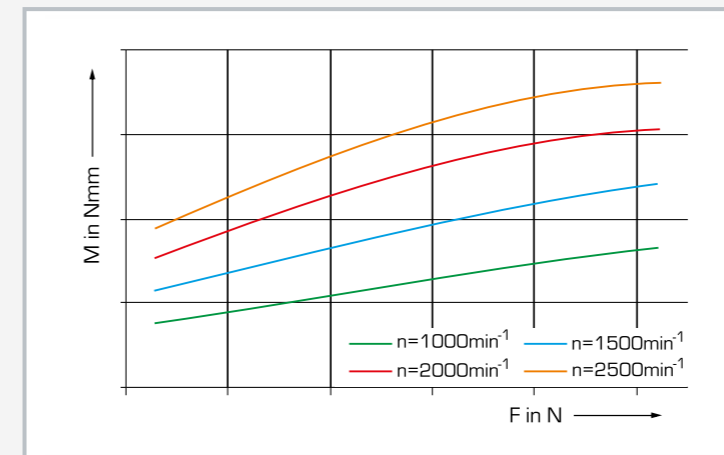

Influence of the loading force F and the speed n on the frictional moment M

Specification

- [1] investigation and visualisation of hydrodynamic bearing
- [2] radial journal bearing with stainless steel journal and freely movable bronze bearing shell
- [3] drip lubrication for continuous supply of lubricant (drip oiler)
- [4] journal bearing subjected to load by means of mechanical lever
- [5] variable speed via frequency converter
- [6] frictional moment measured by level with sliding weight
- [7] inductive speed measurement
- [8] thermocouple in the bearing housing to measure the oil temperature
- [9] display and control unit with digital displays for oil temperature and speed

Technical data

Journal bearing
 ■ shaft diameter: $\varnothing=30\text{mm}$
 ■ bearing width: 45mm
 ■ friction pair: steel/bronze

Motor: 0,37kW
 Oil viscosity grade: ISO VG 32

Weights
 ■ 1x 50N, 1x 20N, 2x 10N, 2x 5N, 2x 5N
 ■ lever transmission ratio: 5:1

Measuring ranges
 ■ temperature: $-50\dots 200^\circ\text{C}$
 ■ speed: $100\dots 3000\text{min}^{-1}$
 ■ bearing load: max. 525N
 ■ friction moment: max. 295Nmm

230V, 50Hz, 1 phase
 230V, 60Hz, 1 phase; 120V, 60Hz, 1 phase
 UL/CSA optional
 LxWxH: 610x440x360mm (experimental unit)
 LxWxH: 360x340x160mm (display and control unit)
 Weight: approx. 40kg

Scope of delivery

- 1 experimental unit
- 1 display and control unit
- 1 set of weights
- 1 oil (0,5L)
- 1 set of instructional material

TM 280

Pressure distribution in journal bearings



Learning objectives/experiments

- visualisation and investigation of instability in journal bearings
- displacement of the shaft journal as a function of the speed
- pressure distribution in the bearing under constant load and different speeds
- critical speed as a function of the load
- critical speed as a function of the oil temperature

Description

- ideal observation of the function thanks to transparent bearing housing
- clear representation of the pressure distribution in the journal bearing
- investigation and visualisation of instability in journal bearings

In hydrodynamic journal bearings, the shaft and the bearing shell are separated from each other by a lubricating film during operation. The supporting function of the lubricating film in a journal bearing can be described by the pressure distribution in the bearing gap.

The TM 280 unit is used to visualise the pressure curve in the journal bearing with hydrodynamic lubrication. To do this, there are twelve measuring points around the circumference of the bearing shell and four measuring points in the longitudinal direction. The respective pressures can be read via a 16 tube manometers with reference to the height of the liquid columns.

The journal bearing comprises an electrically driven shaft journal that rotates in a freely movable bearing housing. Oil is used as the lubricant.

The displacement of the shaft journal depends on the speed and direction of rotation as well as the characteristic behaviour during start-up, and can be observed through the transparent bearing housing. Speed and direction can be adjusted. The load on the journal bearing can be adjusted by varying the weights. The temperature in the bearing gap is measured in order to determine the viscosity of the lubricant.

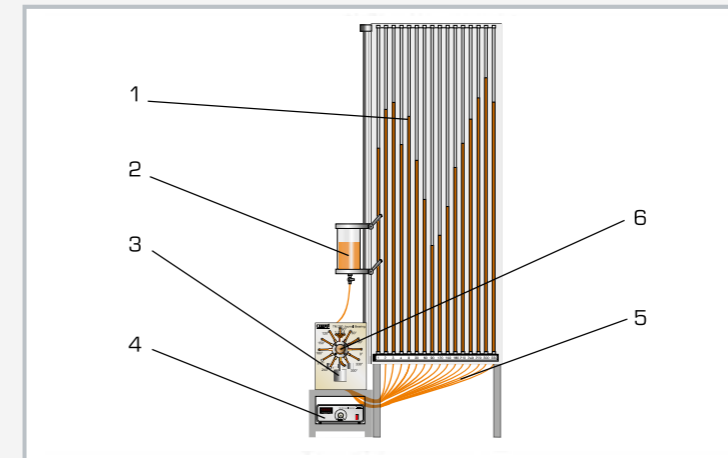

1 tube manometers, 2 tank for oil, 3 weight, 4 display and control unit for speed control, 5 measuring hoses, 6 journal bearing with drive

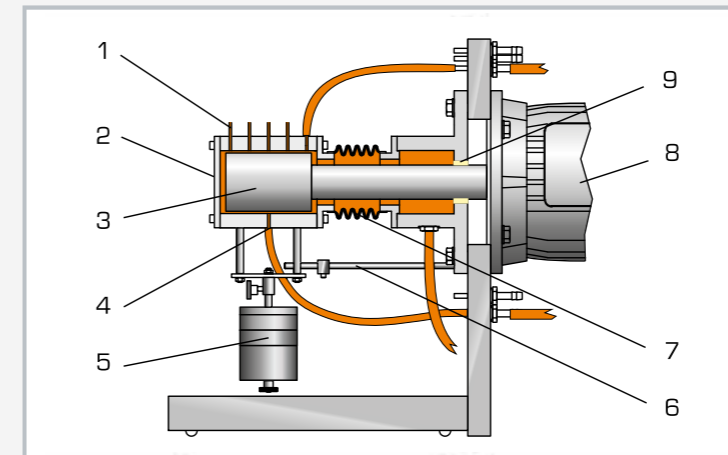

1 measuring points, 2 transparent bearing housing, 3 journal, 4 measuring point, 5 weight, 6 anti-twist device, 7 bellows, 8 drive motor, 9 radial sealing ring

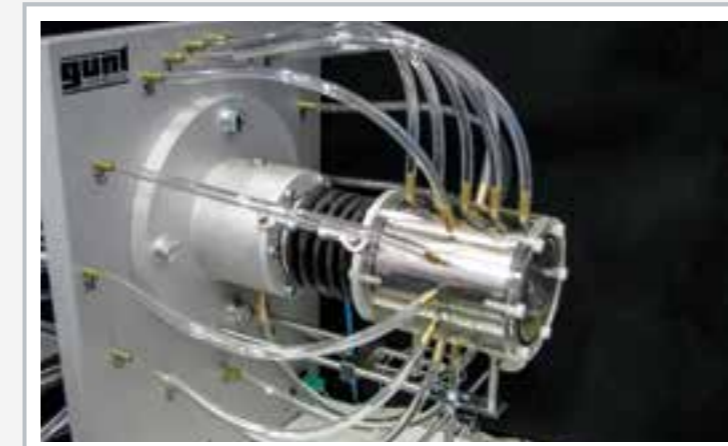

Detailed view of the TM 280 journal bearing unit

Specification

- [1] visualisation and investigation of pressure distribution in journal bearings
- [2] bearing housing is completely transparent
- [3] continuously adjustable speed, electronically controlled
- [4] bearing subjected to load by means of weights
- [5] temperature measurement in the bearing housing
- [6] 12 measuring points on the periphery, 4 measuring points in the longitudinal direction
- [7] pressure distribution indicated with 16 tube manometers
- [8] digital display of speed on the display and control unit

Technical data

Bearing

- nominal bearing diameter: 51mm
- bearing gap width: 4mm
- bearing width: 75mm
- bearing load: 6,7...16,7N

Motor

- power: 0,37kW
- max. speed: 3000min⁻¹

Oil ISO viscosity grade: VG 32

Tank for oil: 2,5L

Weights

- 1x 1N (hanger)
- 2x 2N
- 1x 5N

Measuring ranges

- pressure: 1770mm oil column, 16x
- temperature: -10...50°C
- speed: 0...3000min⁻¹

230V, 50Hz, 1 phase

230V, 60Hz, 1 phase; 120V, 60Hz, 1 phase

UL/CSA optional

LxWxH: 1100x750x2650mm

Weight: approx. 110kg

Scope of delivery

- 1 trainer
- 1 display and control unit
- 1 set of tools
- 1 set of weights
- 1 hydraulic oil [5L]
- 1 handheld temperature measuring unit
- 1 set of instructional material

TM 290

Journal bearing with hydrodynamic lubrication



Learning objectives/experiments

- determine the coefficients of friction at various loads and speeds, compare with Stribeck curves
- influence of speed, bearing clearance and bearing load on the displacement of the shaft
- influence of speed, bearing clearance, bearing load and lubricant on the frictional moment
- locus of the shaft

Description

- frictional moment under different bearing clearances and loads
- pressure distribution in the journal bearing
- locus of the shaft under different loads and speeds

In hydrodynamic bearings, the shaft and the bearing shell are separated from each other during operation by a supporting lubricating film. The pressure in the lubricating film in hydrodynamic journal bearings is generated by the relative motion between bearing shell and shaft. The position of the shaft in relation to the speed and the load is important for an analysis of the tribological process in the bearing shell of a journal bearing.

The TM 290 trainer allows the study of a hydrodynamically lubricated radial journal bearing. Five shafts with different diameters allow the operating behaviour to be analysed as a function of the bearing clearance.

The radial load on the journal bearing is applied by means of a handwheel and measured electronically. Similarly, the frictional moment is measured using a force sensor. The shaft is driven by a three-phase motor. The speed is continuously adjustable via a frequency converter and is displayed digitally. The oil temperature is adjusted using a controller.

Inductive sensors detect the relative motion of the shaft in the bearing. This measurement makes it possible to plot a locus of the shaft as a function of load and speed. The position is measured, averaged and displayed at four points on the shaft in each of the X and Y directions.

Oil temperature, oil pressure and oil peak pressure in the bearing are measured and displayed by additional sensors. The measured values are read from digital displays and can be transmitted simultaneously via USB directly to a PC where they can be analysed using the software included.



1 handwheel for load, 2 force sensor for frictional moment, 3 inductive displacement sensors, 4 shaft, 5 bearing housing, 6 displays and controls

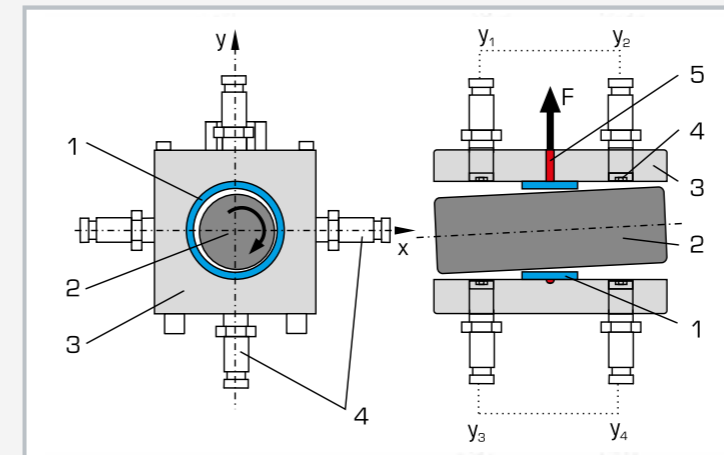

Sectional views of the journal bearing: 1 bearing shell, 2 shaft, 3 bearing housing, 4 displacement sensors (4 in X direction, 4 in Y direction), 5 oil supply, F load

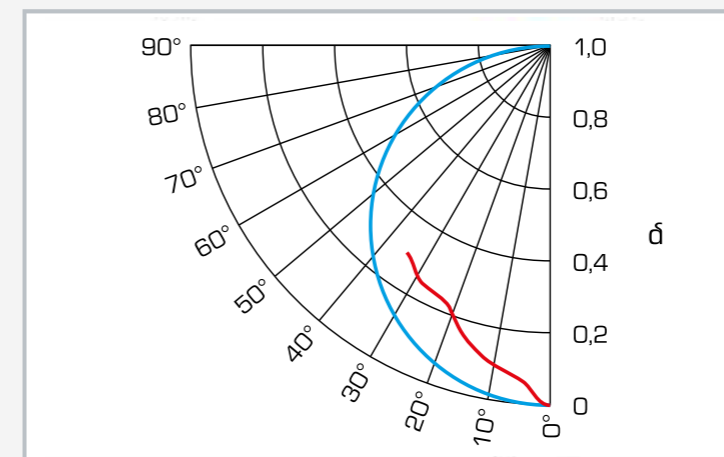

Movement of the shaft centre point during operation or startup behaviour, blue: theoretical semicircle curve, red: measuring results of TM 290, d relative lubricating film thickness

Specification

- [1] friction states in hydrodynamically lubricated journal bearing
- [2] 5 shafts with different diameters for experiments with different bearing clearances
- [3] shaft driven by three-phase motor with frequency converter for continuous adjustment of the speed controller to adjust the oil temperature
- [4] radial load of the bearing by means of compression spring and threaded spindle with handwheel and measured via force sensor
- [5] determine the frictional moment by means of lever arm with force sensor
- [6] 8 inductive displacement sensors for measuring the displacement of the shaft
- [7] digital displays for radial load, frictional moment, position of the shaft (X and Y direction), oil pressure, peak oil pressure, oil temperature and speed
- [8] GUNT software for data acquisition via USB under Windows 7, 8.1, 10

Technical data

Journal bearing

- rated diameter of the shaft: 50mm
- radial load: 0...1000N
- bearing clearance: 0,12mm; 0,14mm; 0,16mm; 0,18mm; 0,28mm

Drive motor with frequency converter

- power: 0,55kW
 - speed: 0...1600min⁻¹
- Hydraulic unit to adjust the oil temperature
- flow rate: 1,4L/min, pressure: 2bar
 - tank capacity: 10L

Measuring ranges

- frictional moment: 0...1Nm
- radial load: 0...1000N
- displacement in X direction: $\pm 1,000$ mm
- displacement in Y direction: $\pm 1,000$ mm
- oil pressure supply: 1x 0...10bar
- oil pressure journal bearing: 1x 0...16bar
- oil temperature: 0...100°C
- speed: 0...1600min⁻¹

230V, 50Hz, 1 phase
230V, 60Hz, 1 phase; 120V, 60Hz, 1 phase
UL/CSA optional
LxWxH: 1200x800x1450mm
Weight: approx. 225kg

Required for operation

PC with Windows recommended

Scope of delivery

- 1 trainer
- 1 set of tools
- 1 oil (5L)
- 1 GUNT software CD + USB cable
- 1 set of instructional material

CE 105

Corrosion of metals



Description

- principles of corrosion and corrosion protection on metallic materials
- oxygen corrosion
- electrochemical corrosion (local elements)
- corrosion protection with external voltage and sacrificial anodes

Corrosion damage to metallic components causes considerable economic and technical damages. The issue of corrosion and corrosion protection therefore plays an important role in technical training.

The CE 105 allows a variety of factors that influence corrosion processes to be investigated in parallel. Eight glass vessels are available to do this. They allow different materials to be compared under different conditions. The required electrolyte solution is added to the vessels. Up to six specimens can be attached to the cover of each vessel and these are immersed in the solution.

It is possible to connect specimens to an electrical conductor to investigate local elements and the principle of sacrificial anodes. An adjustable power pack allows an external voltage to be connected. This counters the current flow between precious and base metals in local elements. As a result the corrosion rate of the more base metal is reduced.

A diaphragm pump conveys ambient air into the electrolyte solution as required. Flow control valves can be used to individually adjust the gas flow rate for each vessel. It is also possible to feed other gases provided by the laboratory into the electrolyte solution. A pH meter is included to allow the influence of the electrolyte solution on corrosion processes to be investigated and compared.

Learning objectives/experiments

- corrosion behaviour of different metallic materials (rust / passivation)
- formation of local elements
- influence of pH value of the electrolyte solution
- influence of salt concentration in the electrolyte solution
- oxygen corrosion
- corrosion protection
 - ▶ external voltage
 - ▶ sacrificial anodes
 - ▶ protective layers

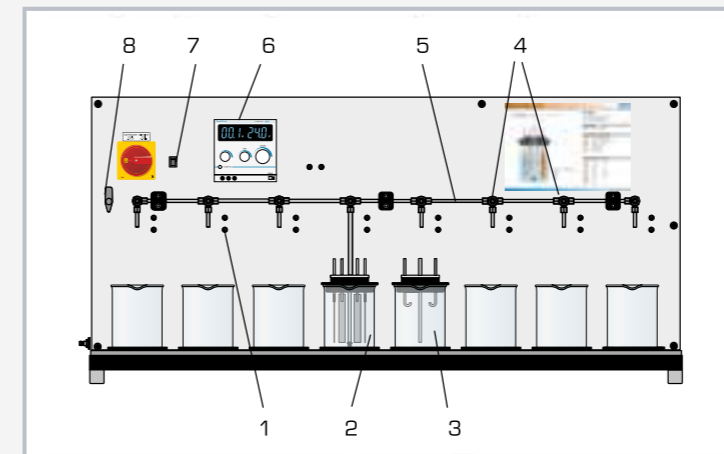

1 electrical connecting sockets, 2 electrolyte vessel with specimens and specimen holders (clamps), 3 electrolyte vessel with specimen holders (hooks), 4 flow control valves, 5 gas supply, 6 power pack, 7 diaphragm pump switch, 8 air / external gas supply reversing valve

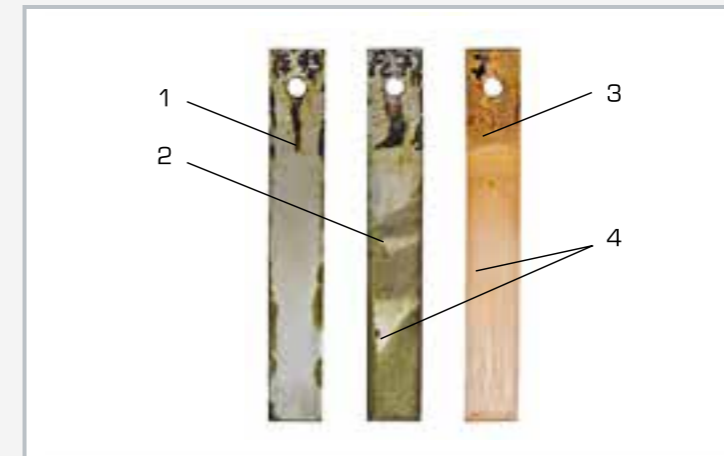

Experimental result: a steel specimen (2) and a copper specimen (3) were electrically connected (4) and supplied with an external voltage. A steel specimen (1) with no electrical connection was used as a reference.

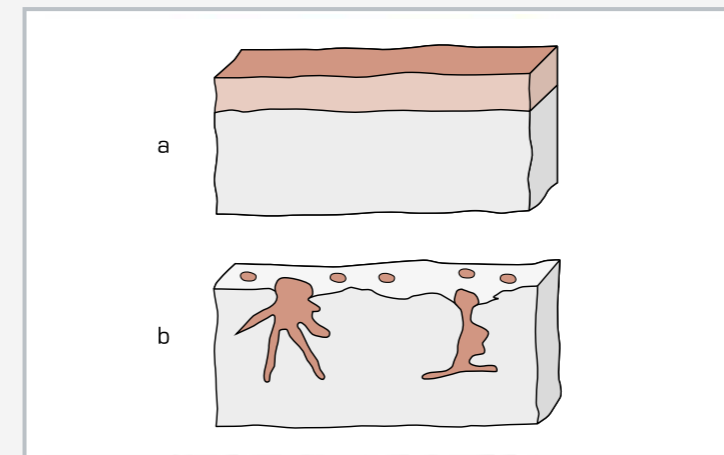

Two corrosion types: a surface corrosion, b pitting

Specification

- [1] investigation of corrosion and corrosion protection measures
- [2] 8 electrolyte vessels with covers and 6 specimen holders each
- [3] adjustable power pack for application of external voltage
- [4] air supply via diaphragm pump
- [5] reversing valve for air or external gas supply
- [6] adjustment of gas flow rate for each vessel using flow control valves
- [7] recording of pH value of electrolyte solutions using manual unit
- [8] pressure range for external gas supply: 0,2...1,0bar

Technical data

Electrolyte vessels
 ■ capacity: 1000mL
 ■ material: glass

Power pack
 ■ voltage: 0...30VDC
 ■ current: 0...5A

Diaphragm pump: approx. 260L/h

Specimens
 ■ 6x stainless steel, steel, copper, brass, aluminium
 ■ 3x glass
 ■ dimensions: 100x15x1mm

Measuring ranges
 ■ pH value: 0...14
 ▶ resolution: 0,01

230V, 50Hz, 1 phase
 230V, 60Hz, 1 phase; 120V, 60Hz, 1 phase
 UL/CSA optional
 LxWxH: 1280x460x630mm (experimental unit)
 Weight: approx. 55kg
 LxWxH: 730x480x240mm (storage system)
 Weight: approx. 15kg

Scope of delivery

- 1 experimental unit
- 1 pH meter
- 1 set of specimens
- 1 set of cables
- 1 coupling to connect an external gas supply
- 1 storage system
- 1 set of instructional material

The complete GUNT programme – equipment for engineering education



1

Engineering mechanics and engineering design

- statics
- strength of materials
- dynamics
- machine dynamics
- engineering design
- materials testing



2

Mechatronics

- engineering drawing
- cutaway models
- dimensional metrology
- fasteners and machine parts
- manufacturing engineering
- assembly projects
- maintenance
- machinery diagnosis
- automation and process control engineering



3

Thermal engineering

- fundamentals of thermodynamics
- thermodynamic applications in HVAC
- renewable energies
- thermal fluid energy machines
- refrigeration and air conditioning technology



4

Fluid mechanics

- steady flow
- transient flow
- flow around bodies
- fluid machinery
- components in piping systems and plant design
- hydraulic engineering



5

Process engineering

- mechanical process engineering
- thermal process engineering
- chemical process engineering
- biological process engineering
- water treatment



6

2E Energy & environment

- Energy**
- solar energy
 - hydropower and ocean energy
 - wind power
 - biomass
 - geothermal energy
 - energy systems
 - energy efficiency in building service engineering
- Environment**
- water
 - air
 - soil
 - waste

Planning and consulting · Technical service
Commissioning and training

Index

Keyword	Code (page)
A	
absorber effect	TM 150 (178) TM 182 (210)
abutment line	SE 110.17 (50)
Ackermann steering principle	KI 160 (151)
alignment	MT 172 (308) PT 500 (224)
alignment error	PT 500 (224) PT 500.10 (232) PT 500.13 (238)
alternating torque	PT 500.16 (244)
amplitude response	TM 155 (188)
apparent force	TM 605 (166)
arch	SE 110.16 (52)
articulated beam	SE 110.12 (48)
assembly process	MT 110.02 (306) MT 152 (304) MT 170 (300) MT 171 (302) MT 190 (310) TZ 200.11 (266) TZ 200.71 (268) TZ 300 (264)
asymmetric arch	SE 110.17 (50)
axial run-out	PT 500.13 (238)
axial second moment of area	FL 160 (114)
axial stress	FL 130 (132) FL 140 (134)
B	
backlash	PT 500.15 (242) PT 500.16 (244)
balancing	PT 500 (224) PT 502 (204) TM 170 (202)
bar-type oscillator	TM 150 (178)
beam theory	FL 160 (114) SE 110.14 (82) SE 110.47 (86) WP 100 (90) WP 950 (84)
beam, curved	FL 170 (94)
bearing clearance	MT 170 (300) PT 500.16 (244) TM 290 (374)
bearing condition	PT 501 (220)
bearing damage	PT 500.12 (236) PT 500.15 (242) PT 501 (220)
bearing elements, machine elements	MG 911 (279) MT 170 (300) MT 171 (302)
bearing friction	TM 232 (368) TM 282 (370)
bearing vibrations	PT 500 (224)
bearing, hydrodynamic	TM 282 (370) MT 171 (302)
belt drive	GL 100 (280) GL 410 (288) GL 420 (290) GL 430 (292) TM 220 (74/286) PT 500.14 (240)
belt friction	TM 220 (74/286)
belt tension	PT 500.14 (240)
bend test	FL 100 (122) SE 100 (336) SE 110.14 (82) SE 110.47 (86) SE 110.48 (338) WP 100 (90) WP 300 (332) WP 310 (334)
bending and torsion	FL 160 (114) WP 100 (90) WP 130 (116)
bending beam	FL 160 (114) SE 110.58 (181)
bending deformation of a beam with L-profile cross-section	FL 160 (114)
bending deformation of a beam with U-profile cross-section	FL 160 (114)
bending deformation of a curved beam	FL 170 (94)
bending deformation of a straight beam	FL 100 (122) FL 102 (124) SE 110.47 (86) WP 100 (90) WP 950 (84)
bending moment diagram	WP 960 (30) WP 962 (33)
bending vibration	SE 110.58 (181) PT 500.10 (232) TM 620 (196)
Bernoulli hypothesis	FL 160 (114)
bevel gear	GL 300.02 (269) GL 410 (288) GL 420 (290)
biaxial bending	FL 160 (114)
biaxial stress state	FL 130 (132)
blade oscillation	PT 500.18 (248)
blade pass frequency	PT 500.18 (248)

Keyword	Code (page)
breakaway torque of screws	TM 320 (277)
bridge connection (strain gauge)	FL 100 (122)
Brinell hardness test	MT 190 (310) WP 300 (332) WP 310 (334)
buckling	SE 110.19 (104) SE 110.57 (106) WP 120 (110) WP 121 (108)
buckling force	SE 110.19 (104) WP 120 (110) WP 121 (108)
buckling stress	SE 110.19 (104) WP 120 (110) WP 121 (108)
C	
cable friction	TM 220 (74/286)
cable under constant line load	SE 110.18 (46)
cable under dead weight	SE 110.50 (34)
cable under point load	SE 110.50 (34)
cable winch	TM 125 (284)
cam box	GL 430 (292)
cam mechanism	GL 110 (281) GL 112 (208)
cantilever beam	SE 110.14 (82) SE 110.47 (86) WP 100 (90) WP 950 (84)
cardan error	KI 150 (150)
Castigliano	SE 110.44 (96)
catenary	SE 110.18 (46) SE 110.50 (34)
cavitation in pumps	PT 500.17 (246)
centre distance (gears)	PT 500.15 (242)
centre of gravity	TM 161 (172)
centre of inertia	TM 161 (172)
centrifugal force	TM 600 (162) TM 632 (168)
centrifugal governor	TM 632 (168)
chain gear	GL 410 (288) GL 420 (290)
change gear train	GL 430 (292)
Charpy notched bar impact test	WP 400 (340) WP 410 (342)
circular beam	FL 170 (94)
coefficient of friction	TM 110.01 (18) TM 200 (72) TM 210 (70) TM 225 (73) TM 232 (368) TM 260.01 (356) TM 260.03 (360) TM 260.04 (362) TM 260.05 (364) TM 290 (374) TM 310 (278)
combined load	FL 160 (114)
commutative theories	SE 110.14 (82) WP 950 (84)
composite stress	FL 160 (114) WP 130 (116)
composition of forces	TM 110 (16) TM 115 (21)
compression struts with various support methods	SE 110.19 (104) WP 120 (110) WP 121 (108)
compression test	SE 100 (336) WP 300 (332) WP 310 (334)
connecting elements, machine elements	MG 901 (274) MG 903 (275) MG 905 (276) TM 320 (277) TM 310 (278)
contact area	TM 262 (98)
contact force	TM 262 (98)
control gear	GL 430 (292)
Coriolis force	TM 605 (166)
correlation between damage and running noise	PT 500.12 (236)
corrosion	CE 105 (376)
coupling vibration	PT 500.13 (238)
crack identification	PT 500.11 (234)
crack in the shaft	PT 500.11 (234)
crane boom	TM 115 (21)
crank mechanism	KI 110 (146) KI 120 (147) KI 140 (149) PT 500.16 (244) TM 180 (206)
crank offset	TM 180 (206)
crank slider	KI 120 (147) KI 140 (149)
crank-rocker mechanism	KI 130 (148)
creep rupture test	WP 600 (350)

Keyword	Code (page)
Cremona diagram	SE 130 (42) SE 130.01 (44)
critical speed	PT 500.10 (232) PT 500.14 (240) TM 620 (196) TM 625 (198)
cupping test	WP 300 (332) WP 310 (334)
curved beam	FL 170 (94)
cylindrical workpieces	TZ 100 (258)
D	
damage analysis	PT 500 (224)
damage to gears	PT 500.15 (242)
damage to rolling bearings	PT 500.12 (236) PT 501 (220)
damped vibration	TM 150 (178) TM 155 (188)
deflection of a spring, elastic	TM 110.01 (18)
deflections of beams	SE 110.47 (86) WP 100 (90) WP 950 (84) WP 960 (30) WP 961 (32) WP 962 (33)
deformation energy	SE 110.44 (96)
deformation in tension	FL 100 (122)
deformation in torsion	SE 110.29 (88) WP 100 (90)
deformation of a bar	WP 100 (90)
deformation of a beam	WP 100 (90)
deformation of a beam with a curved axis	FL 170 (94)
deformation of a frame	SE 110.20 (92)
deformation of a parabolic arch	SE 110.16 (52)
deformation of a straight beam	FL 100 (122) FL 102 (124) SE 110.47 (86) WP 950 (84)
deformation of a truss	SE 110.44 (96)
descriptive geometry	TZ 100 (258)
determine modulus of elasticity	FL 100 (122) WP 100 (90) WP 120 (110)
determining bar forces	FL 111 (22) SE 110.21 (38) SE 110.22 (40) SE 110.44 (96) SE 130 (42) TM 115 (21)
diffraction angle (universal joint)	KI 150 (150)
dimensioning	MT 110.02 (306) MT 152 (304) TZ 200.02 (262) TZ 200.08 (263) TZ 200.11 (266) TZ 200.61 (260) TZ 200.71 (268) TZ 300 (264)
direct stress	FL 140 (134) WP 130 (116)
direction of principal stress	FL 120 (130) FL 130 (132) FL 140 (134)
disk cam	GL 110 (281)
double crank	KI 130 (148)
double rocker mechanism	KI 130 (148)
drive belt	TM 170 (202) TM 220 (74/286)
drive systems	GL 410 (288) GL 420 (290) GL 430 (292)
dual belt	PT 500.14 (240)
dynamic friction	TM 110.01 (18) TM 200 (72) TM 210 (70) TM 225 (73) TM 232 (368) TM 260.01 (356) TM 260.03 (360) TM 260.04 (362) TM 260.05 (364)
dynamic fundamental law of rotational movement	TM 612 (156)
dynamic imbalance	PT 500 (224)

Keyword	Code (page)
E	
eccentrically loaded compression struts	WP 120 (110)
efficiency of gears	AT 200 (296) GL 210 (158) GL 212 (160) TM 123 (282)
elastic line	FL 160 (114) SE 110.14 (82) SE 110.20 (92) SE 110.44 (96) SE 110.47 (86) WP 100 (90) WP 950 (84) WP 962 (33)
elastic shaft	PT 500.10 (232)
elastohydrodynamics (EHD theory)	TM 260.02 (358)
electromechanical vibrations	PT 500.19 (250)
elevation curve of cam mechanisms	GL 110 (281) GL 112 (208)
energy methods	SE 110.44 (96)
engineering drawing	TZ 100 (258) TZ 200.02 (262) TZ 200.08 (263) TZ 200.11 (266) TZ 200.61 (260) TZ 200.71 (268) TZ 300 (264)
envelope analysis	PT 500.12 (236) PT 500.16 (244) PT 501 (220)
equilibrium conditions of statics	SE 110.53 (24)
equilibrium of a rigid body	SE 110.53 (24)
equilibrium of forces	TM 110 (16) TM 110.01 (18) TM 225 (73)
equilibrium of moments	EM 049 (23) TM 110 (16) TM 121 (26) TM 122 (27)
Euler's buckling formula	SE 110.57 (106) WP 120 (110) WP 121 (108)
Eytelwein's belt friction formula	TM 220 (74/286)
F	
fatigue fracture	PT 500.11 (234)
fatigue strength test	WP 140 (348)
FFT analysis	PT 500.04 (228)
field balancing	PT 500 (224) PT 500.10 (232) PT 502 (204)
first-order elasticity theory (trusses)	SE 110.20 (92)
flat belt	TM 220 (74/286)
flexibility method	FL 170 (94) WP 950 (84)
flywheel	TM 232 (368) TM 612 (156)
force transmission	TM 110.02 (19) TM 122 (27) TM 125 (284)
forced vibration	TM 140 (192) TM 150 (178) TM 155 (188)
forces at a section on a beam	WP 960 (30) WP 961 (32) WP 962 (33)
forces at a section on a frame	SE 110.20 (92)
forces at a section: normal force, shear force, bending moment	WP 960 (30) WP 961 (32) WP 962 (33)
forces with a common point of action	TM 110 (16)
four-joint link	KI 130 (148)
fracture behaviour	WP 400 (340) WP 410 (342)
frame, deformation	SE 110.20 (92)
free vibration	SE 110.58 (181) TM 155 (188)
free-body diagram	SE 110.21 (38) SE 110.22 (40) SE 110.53 (24) SE 130 (42)
frequency spectra	PT 500 (224)
friction	TM 110.01 (18) TM 200 (72) TM 210 (70) TM 220 (74/286) TM 225 (73)
friction gear	GL 100 (280)
friction oscillation	TM 260.04 (362)
friction wheels	TM 260.01 (356)
friction, roller bearing	TM 232 (368)
friction, slide bearing	TM 232 (368) TM 282 (370)
frictional force	TM 200 (72) TM 210 (70) TM 260.01 (356) TM 260.03 (360) TM 260.04 (362) TM 260.05 (364)
frictional forces on journal bearings	TM 232 (368)
fundamental equation of straight bending	SE 110.47 (86) WP 950 (84)

Index

Keyword	Code (page)
G	
gas force	PT 500.16 (244)
gear	GL 100 (280) GL 410 (288) MT 152 (304) PT 500.15 (242)
gear coupling	PT 500.13 (238)
gear drive	GL 100 (280) GL 105 (152) GL 212 (160) GL 410 (288) PT 500.15 (242) TM 110.03 (20) TM 123 (282)
gear efficiency	TM 123 (282)
gear function	GL 410 (288) GL 420 (290) GL 430 (292) TM 123 (282)
geometric models	TZ 100 (258)
Gerber beam	SE 110.12 (48)
graphical method for determination of shear force diagrams and moment diagrams	SE 110.47 (86)
Grashof condition	KI 130 (148)
gravity pendulum	TM 161 (172)
guided spinning top	TM 630 (164)
gyroscope	TM 630 (164)
gyroscopic effect	PT 500.18 (248)
gyroscopic laws	TM 630 (164)
gyroscopic moments	TM 630 (164)
H	
Hartnell governor	TM 632 (168)
helical gears	PT 500.15 (242)
helical worm gear	MT 110.02 (306)
Hertzian pressure	TM 262 (98)
Hooke's law	TM 110.01 (18) TM 400 (100)
Howe truss	SE 130 (42)
hydrodynamic slide bearing	MT 171 (302) TM 260.06 (366) TM 282 (370)
I	
idle time	PT 500 (224)
imbalance	PT 500 (224)
imbalance, dynamic	PT 502 (204) TM 170 (202)
imbalance, general	PT 502 (204) TM 170 (202)
imbalance, static	PT 502 (204) TM 170 (202)
impact test	WP 400 (340) WP 410 (342)
inclined plane	TM 110.01 (18) TM 225 (73) TM 611 (155)
indeterminate truss	SE 110.22 (40)
inertia force	PT 500.16 (244) TM 180 (206)
influence coefficients	WP 950 (84)
influence line	SE 110.12 (48) SE 110.17 (50) WP 950 (84)
influence of the modulus of elasticity	WP 100 (90) WP 120 (110) WP 950 (84)
internal forces and moments	SE 110.12 (48) SE 110.18 (46) WP 960 (30) WP 961 (32) WP 962 (33)
isochromats	FL 200 (136) FL 210 (138)
K	
Kater's pendulum	TM 150 (178)
k-factor of a strain gauge	FL 102 (124)
L	
Laval rotor	TM 625 (198)
law of elasticity	FL 130 (132) TM 400 (100)
law of falling bodies	TM 611 (155)
lead angle	KI 160 (151)

Keyword	Code (page)
lever principle	EM 049 (23) TM 110 (16)
lifting work	TM 110.02 (19)
line load	SE 110.12 (48) SE 110.16 (52) SE 110.17 (50) SE 110.18 (46)
load curve, bending beam	SE 110.48 (338)
load-extension diagram	MT 190 (310) MT 190.01 (312) SE 110.48 (338)
lubricating film	TM 260.02 (358) TM 260.03 (360) TM 260.06 (366) TM 280 (372) TM 282 (370) TM 290 (374)
lubricating gap	TM 260.06 (366) TM 280 (372) TM 282 (370) TM 290 (374)
M	
machine diagnosis	PT 500 (224)
machine elements, bearing elements	MG 911 (279) MT 170 (300) MT 171 (302)
machine elements, connecting elements	MG 901 (274) MG 903 (275) MG 905 (276) TM 320 (277) TM 310 (278)
machine elements, transmission elements	GL 100 (280) GL 110 (281) TM 123 (282) TM 124 (283) TM 125 (284) TM 220 (74/286)
machine vibrations	PT 500 (224) PT 500.19 (250) PT 502 (204)
machinery status monitoring	PT 500 (224)
magnetic particle brake	AT 200 (296)
manufacturing information	TZ 200.08 (263) TZ 200.11 (266) TZ 200.61 (260) TZ 200.71 (268) TZ 300 (264)
mass moment of inertia	TM 140 (192) TM 162 (173) TM 163 (174) TM 610 (154) TM 611 (155) TM 612 (156)
material fatigue	PT 500.11 (234) WP 140 (348) WP 600 (350)
materials testing	MT 190 (310) SE 100 (336) WP 140 (348) WP 300 (332) WP 310 (334) WP 400 (340) WP 410 (342) WP 500 (344) WP 510 (346) WP 600 (350)
mathematical pendulum	TM 150 (178) TM 161 (172) TM 162 (173)
Maxwell-Betti	SE 110.14 (82) WP 950 (84)
measurement exercises	TZ 100 (258) TZ 200.08 (263) TZ 200.11 (266) TZ 200.61 (260) TZ 200.71 (268) TZ 300 (264)
mechanical drives	GL 410 (288) GL 420 (290) GL 430 (292)
mechanical friction	TM 200 (72) TM 210 (70) TM 220 (74/286) TM 225 (73)
method of joints	FL 111 (22) SE 110.21 (38) SE 110.22 (40) SE 130 (42) SE 130.01 (44)
method of sections	SE 110.12 (48) WP 960 (30) WP 961 (32) WP 962 (33)
method of sections (Ritter)	SE 110.21 (38) SE 110.22 (40) SE 130 (42) SE 130.01 (44)
model ship	HM 159.11 (194)
Mohr's method on area of moments	SE 110.47 (86)
Mohr's strain circle	FL 120 (130) FL 130 (132)
Mohr's stress circle	FL 130 (132) FL 140 (134) FL 200 (136) FL 210 (138) WP 130 (116)
moment of deviation	FL 160 (114)
moment of inertia	TM 140 (192) TM 162 (173) TM 163 (174) TM 610 (154) TM 611 (155) TM 612 (156)
moving load	SE 110.12 (48) SE 110.17 (50) SE 110.18 (46)
multi-axial load	FL 160 (114) WP 130 (116)
multi-part structures	SE 110.12 (48)
multiple belt drive	PT 500.14 (240)
multi-span beam	SE 110.47 (86) WP 950 (84)

Keyword	Code (page)
N	
natural frequency	HM 159.11 (194) SE 110.58 (181) TM 150.02 (190) TM 164 (175)
natural mode of a body	HM 159.11 (194) TM 625 (198)
natural vibration	HM 159.11 (194)
Norton gear	GL 200 (294) GL 430 (292)
notched bar impact strength	WP 400 (340) WP 410 (342)
notched bar impact work	WP 400 (340) WP 410 (342)
notched bar impact work-temperature diagram	WP 400 (340) WP 410 (342)
nuts	MG 901 (274)
O	
oblique bending	FL 160 (114)
operational vibration	PT 500.17 (246) TM 182 (210)
orbit	PT 500.10 (232)
order analysis	PT 500.16 (244) PT 501 (220)
oscillating mass	PT 500.16 (244)
out-of-balance excitation	PT 500.10 (232) TM 150 (178) TM 155 (188) TM 182 (210)
out-of-balance vibrations	PT 500 (224) PT 502 (204) TM 170 (202)
P	
parabolic arch	SE 110.16 (52)
parallelogram of forces	TM 110 (16) TM 115 (21)
parts list	TZ 200.08 (263) TZ 200.11 (266) TZ 200.71 (268) TZ 300 (264)
pedestal bearing	GL 300.12 (269)
pendulum	TM 150 (178) TM 161 (172) TM 162 (173)
pendulum impact test	WP 400 (340) WP 410 (342)
pendulum swing	TM 150 (178) TM 161 (172)
phase response	TM 150 (178) TM 155 (188)
photoelasticity	FL 200 (136) FL 210 (138)
physical pendulum	TM 150 (178) TM 162 (173) TM 611 (155)
piston mechanism	PT 500 (224)
pitch error	PT 500.13 (238)
pitch, thread	MG 905 (276)
pivot gear	KI 130 (148)
plane stress state	FL 120 (130) FL 130 (132)
planetary gear	GL 105 (152) GL 212 (160) GL 300.05 (269)
Poisson ratio	FL 130 (132)
polar second moment of area	SE 110.20 (92) SE 110.29 (88)
polariscope	FL 200 (136) FL 210 (138)
Porter governor	TM 632 (168)
precession	TM 630 (164)
pressure distribution in the journal bearing	TM 260.06 (366) TM 280 (372) TM 290 (374)
principal strain	FL 120 (130) FL 130 (132) FL 140 (134)
principal stress	FL 120 (130) FL 130 (132) FL 140 (134)
principal stress differential	FL 200 (136) FL 210 (138)
principle of virtual displacement	SE 110.20 (92)
principle of virtual forces	FL 170 (94) SE 110.20 (92)
principle of virtual work	SE 110.20 (92) SE 110.47 (86) WP 100 (90) WP 950 (84)
Proell governor	TM 632 (168)
pulley block	TM 110.02 (19)
pure bending moment	WP 130 (116)
pure torsional moment	WP 130 (116)

Keyword	Code (page)
Q	
quadrant beam	FL 170 (94)
quick-return mechanism	KI 140 (149)
R	
rack-and-pinion drive	GL 410 (288) GL 420 (290)
radial crack	PT 500.11 (234)
radial run-out	PT 500.13 (238) PT 500.14 (240)
radial strain	FL 120 (130) FL 140 (134)
radial stress	FL 120 (130) FL 140 (134)
Raleigh's approximation method	SE 110.58 (181)
ramp-up curve	PT 500.04 (228) PT 501 (220)
Rankine yield criterion	WP 130 (116)
resolution of forces	FL 111 (22) TM 110 (16) TM 115 (21)
resonance	PT 500 (224) PT 500.10 (232) PT 500.14 (240) TM 140 (192) TM 150 (178) TM 155 (188) TM 620 (196) TM 625 (198)
reverse bending stress	WP 140 (348)
rigid shaft	PT 500 (224)
Ritter's method of sections	SE 110.21 (38) SE 110.22 (40) SE 130 (42) SE 130.01 (44)
rod pendulum	TM 161 (172)
roller bearing	MG 911 (279) PT 500.12 (236) PT 501 (220) TM 232 (368)
roller bearing state	PT 500.12 (236) PT 501 (220)
rolling friction	TM 110.01 (18) TM 232 (368) TM 260.01 (356)
rotor	PT 500.10 (232) PT 500.11 (234) TM 620 (196) TM 625 (198)
running noise	MT 110.02 (306) PT 500.12 (236) PT 500.14 (240)
S	
screw connection	TM 320 (277)
screw thread	TM 320 (277)
screws	MG 901 (274)
sectional view	TZ 200.11 (266) TZ 200.61 (260) TZ 200.71 (268) TZ 300 (264)
self-centring	TM 620 (196) TM 625 (198)
self-locking	TM 124 (283)
semi-circular beam	FL 170 (94)
shaft vibrations	PT 500 (224)
shaft with crack	PT 500 (224) PT 500.11 (234)
shaft, elastic	PT 500.10 (232)
shaft, rigid	PT 500 (224)
shear centre	FL 160 (114)
shear flow in thin-walled beams	FL 160 (114)
shear force and bending moment diagrams	SE 110.12 (48) SE 110.20 (92) SE 110.47 (86) WP 960 (30)
shear force diagram	WP 960 (30) WP 961 (32)
shear modulus	SE 110.29 (88) WP 100 (90)
shear stress	FL 160 (114) SE 110.29 (88)
shear test	WP 300 (332) WP 310 (334)
single-span beam	SE 110.47 (86) WP 100 (90) WP 950 (84)
skew	PT 500.14 (240)
slide bearing	MT 170 (300) MT 171 (302) TM 232 (368) TM 260.06 (366) TM 282 (370) TM 290 (374)
sliding gear drive	GL 430 (292)

Index

Keyword	Code (page)
slip	PT 500.14 (240) TM 260.01 (356)
slip-stick phenomenon	TM 200 (72) TM 210 (70) TM 225 (73) TM 260.04 (362)
spatial imagination	TZ 100 (258)
spatial thinking	TZ 100 (258)
speed control	TM 632 (168)
spinning top	TM 630 (164)
spring characteristic	WP 300 (332)
spring stiffness	TM 164 (175) TM 400 (100)
spring testing	WP 300 (332) WP 310 (334)
springing line	SE 110.17 (50)
spring-mass system	TM 150 (178) TM 164 (175) TM 400 (100)
springs combined in series	TM 400 (100)
spur gear	AT 200 (296) GL 105 (152) GL 300.03 (269) GL 410 (288) GL 420 (290) TM 123 (282) MT 152 (304)
S-shaped frame	SE 110.20 (92)
stability problems (bar)	SE 110.19 (104) WP 120 (110) WP 121 (108)
standard parts	MG 901 (274) MG 911 (279)
static friction	TM 110.01 (18) TM 200 (72) TM 210 (70) TM 225 (73) TM 260.04 (362)
static imbalance	PT 500 (224)
statically indeterminate system	SE 110.14 (82) SE 110.16 (52) SE 110.20 (92) SE 110.22 (40) SE 110.44 (96) SE 110.47 (86) WP 100 (90) WP 950 (84)
steering geometry	KI 160 (151)
Steiner's theorem	TM 611 (155)
step pulley gear	GL 300.06 (269) GL 430 (292)
stiffness change	PT 500.11 (234)
stiffness hypotheses	WP 130 (116)
straight bending on a beam	FL 160 (114)
straight-toothed, gears	PT 500.15 (242)
strain gauge	FL 100 (122) FL 102 (124) FL 120 (130) FL 130 (132) FL 140 (134)
strain-time diagram	WP 600 (350)
stress analysis	FL 120 (130) FL 130 (132) FL 140 (134)
stress hypothesis	WP 130 (116)
stress patterns	FL 200 (136) FL 210 (138)
stress-strain diagram	MT 190 (310) MT 190.01 (312) WP 300 (332) WP 310 (334)
Stribeck curve	TM 290 (374)
subcritical orbit	PT 500.10 (232)
supercritical orbit	PT 500.10 (232)
superposition method	SE 110.47 (86) SE 110.20 (92)
support reaction	SE 110.12 (48) SE 110.16 (52) SE 110.17 (50) SE 110.21 (38) SE 110.22 (40) SE 110.44 (96) SE 130 (42) WP 950 (84)
surface information	TZ 200.08 (263) TZ 200.11 (266) TZ 200.61 (260) TZ 200.71 (268) TZ 300 (264)
suspension bridge	SE 110.18 (46)
symmetrical arch	SE 110.17 (50)
system of forces in the plane	FL 111 (22) SE 110.53 (24) TM 110 (16) TM 115 (21)

Keyword	Code (page)
T	
tangential strain	FL 120 (130) FL 130 (132) FL 140 (134)
tangential stress	FL 120 (130) FL 130 (132) FL 140 (134)
tensile test	MT 190 (310) WP 300 (332) WP 310 (334)
thick-walled container under pressure	FL 140 (134)
thin-walled container under pressure	FL 130 (132)
thread efficiency	TM 310 (278)
thread lock	MG 903 (275) TM 320 (277)
thread pitch	TM 320 (277)
thread types	MG 905 (276) TM 310 (278)
three-dimensional display	TZ 100 (258)
three-hinged arch	SE 110.17 (50)
three-span beam	SE 110.12 (48) WP 950 (84)
tightening torque of screws	TM 320 (277)
tolerances	TZ 200.08 (263) TZ 200.11 (266) TZ 200.61 (260) TZ 200.71 (268) TZ 300 (264)
tooth damage	PT 500.15 (242)
toothing error	PT 500.15 (242)
torsion	TM 140 (192) TM 150.02 (190) TM 163 (174)
torsion of a rectangular tube	SE 110.29 (88)
torsion of a round bar	FL 100 (122) SE 110.29 (88) WP 100 (90) WP 500 (344) WP 510 (346)
torsion of a tube	SE 110.29 (88)
torsion of a tube split in the longitudinal direction	SE 110.29 (88)
torsion test	FL 100 (122) SE 110.29 (88) WP 100 (90) WP 500 (344) WP 510 (346)
torsional stiffness	TM 140 (192) TM 150.02 (190) SE 110.29 (88)
torsional vibration	TM 140 (192) TM 150.02 (190) TM 162 (173) TM 163 (174) TM 164 (175)
tracking analysis	PT 500 (224)
transmission elements, machine elements	GL 100 (280) GL 110 (281) TM 123 (282) TM 124 (283) TM 125 (284) TM 220 (74/286)
transmission ratio	GL 105 (152) GL 410 (288) GL 420 (290) GL 430 (292) TM 110.03 (20) TM 123 (282) TM 124 (283) TZ 200.71 (268) TZ 300 (264)
Tresca yield criterion	FL 140 (134) WP 130 (116)
triaxial stress state	FL 140 (134)
tribology	TM 232 (368) TM 260 (354) TM 280 (372) TM 282 (370) TM 290 (374)
tripping device for lathe	GL 430 (292)
truss	FL 111 (22) SE 110.21 (38) SE 110.22 (40) SE 110.44 (96) SE 130 (42)
tumbler gear	GL 430 (292)
twisting angle	SE 110.29 (88) WP 100 (90) WP 500 (344) WP 510 (346)
twisting moment	SE 110.29 (88) WP 100 (90) WP 130 (116) WP 500 (344) WP 510 (346)
twisting moment – twisting angle diagram	WP 500 (344) WP 510 (346)
twisting strength	WP 500 (344) WP 510 (346)
two-span beam	SE 110.14 (82) SE 110.47 (86) WP 950 (84)

Keyword	Code (page)
U	
undamped oscillation	TM 150 (178)
uniaxial bending	FL 160 (114) WP 130 (116)
uniaxial stress state	WP 130 (116)
uniformly accelerated rotational motion	TM 612 (156)
universal joint shaft	KI 150 (150)
unloading curve, bending beam	SE 110.48 (338)
U-shaped frame	SE 110.20 (92)
V	
variable-speed gear, sectional model	GL 300.07 (269)
V-belt	PT 500.14 (240) TM 220 (74/286)
vibration absorber	TM 182 (210)
vibration measurement equipment	PT 500 (224) PT 500.04 (228)
vibration spectrum	PT 500 (224) PT 500.11 (234) PT 500.12 (236) PT 500.14 (240) PT 500.16 (244) PT 500.17 (246) PT 500.18 (248) PT 501 (220)
vibration, damped	TM 140 (192) TM 150 (178) TM 150.02 (190) TM 155 (188) TM 182 (210)
vibrations in couplings	PT 500.13 (238)
vibrations in fans	PT 500.18 (248)
vibrations in roller bearings	PT 500.12 (236)
vibrations on belt drives	PT 500.14 (240)
vibrations on crank drives	PT 500.16 (244)
vibrations on machine foundations	TM 182 (210)
vibrations, electromechanical	PT 500.19 (250)
virtual work	SE 110.20 (92) SE 110.47 (86) WP 950 (84)

Keyword	Code (page)
W	
Warren truss	SE 130.01 (44)
wear in gears	PT 500.15 (242)
wear in tribological systems	TM 260.03 (360) TM 260.05 (364)
wear measurement	PT 500.16 (244)
Wheatstone bridge	FL 100 (122)
Whitworth mechanics	KI 140 (149)
Whitworth thread	MG 905 (276)
Woehler diagram	WP 140 (348)
work, virtual	SE 110.20 (92) SE 110.47 (86)
work-energy theorem	SE 110.44 (96)
worm gear	AT 200 (296) GL 300.01 (268) GL 420 (290) TM 124 (283)
wrap angle	GL 410 (288) TM 220 (74/286)

Keyword	Code (page)
Y	
yielding point	WP 130 (116)
Z	
zero members; in trusses	SE 110.21 (38) SE 110.22 (40) SE 110.44 (96)

Product overview

AT		
AT 200	Determination of gear efficiency	296
CE		
CE 105	Corrosion of metals	376
EM		
EM 049	Equilibrium of moments on a two-arm lever	23
FL		
FL 100	Strain gauge training system	122
FL 101	Strain gauge application set	120
FL 102	Determining the gauge factor of strain gauges	124
FL 111	Forces in a simple bar structure	22
FL 120	Stress and strain analysis on a membrane	130
FL 130	Stress and strain analysis on a thin-walled cylinder	132
FL 140	Stress and strain analysis on a thick-walled cylinder	134
FL 152	Multi-channel measuring amplifier	56/128
FL 160	Unsymmetrical bending	114
FL 170	Deformation of curved-axis beams	94
FL 200	Photoelastic experiments with a transmission polariscope	136
FL 210	Photoelastic demonstration	138
GL		
GL 100	Principle of gear units	280
GL 105	Kinematic model: gear drive	152
GL 110	Cam mechanism	281
GL 112	Investigation of cam mechanisms	208
GL 200	Lathe gear	294
GL 210	Dynamic behaviour of multistage spur gears	158
GL 212	Dynamic behaviour of multistage planetary gears	160
GL 300.01– GL 300.12	Cutaway models	270 271
GL 410	Assembly simple gears	288
GL 420	Assembly combined gears	290
GL 430	Assembly control gear	292
HM		
HM 159.11	Natural vibration on a ship model	194
KI		
KI 110	Kinematic model: crank mechanism	146
KI 120	Kinematic model: crank slider	147
KI 130	Kinematic model: four-joint link	148
KI 140	Kinematic model: Whitworth quick return mechanism	149
KI 150	Kinematic model: Hooke's coupling	150
KI 160	Kinematic model: Ackermann steering mechanism	151
MG		
MG 901	Nuts and bolts kit	274
MG 903	Screw-locking devices kit	275
MG 905	Thread types kit	276
MG 911	Roller bearings kit	279

MT		
MT 110.02	Assembly spur wheel / worm gear mechanism	306
MT 152	Assembly spur gear	304
MT 170	Assembly shaft with journal bearings	300
MT 171	Assembly hydrodynamic journal bearing	302
MT 172	Alignment of drives, shafts and gears	308
MT 190	Assembly materials tester	310
MT 190.01	Assembly data acquisition for materials tester	312

PT		
PT 500	Machinery diagnostic system, base unit	224
PT 500.01	Laboratory trolley	227
PT 500.04	Computerised vibration analyser	228
PT 500.05	Brake & load unit	230
PT 500.10	Elastic shaft kit	232
PT 500.11	Crack detection in rotating shaft kit	234
PT 500.12	Roller bearing faults kit	236
PT 500.13	Couplings kit	238
PT 500.14	Belt drive kit	240
PT 500.15	Damage to gears kit	242
PT 500.16	Crank mechanism kit	244
PT 500.17	Cavitation in pumps kit	246
PT 500.18	Vibrations in fans kit	248
PT 500.19	Electromechanical vibrations kit	250
PT 501	Roller bearing faults	220
PT 502	Field balancing	204

SE		
SE 100	Frame for load testing, 400kN	336
SE 110.12	Lines of influence on the Gerber beam	48
SE 110.14	Elastic line of a beam	82
SE 110.16	Parabolic arch	52
SE 110.17	Three-hinged arch	50
SE 110.18	Forces on a suspension bridge	46
SE 110.19	Investigation of simple stability problems	104
SE 110.20	Deformation of frames	92
SE 110.21	Forces in various single plane trusses	38
SE 110.22	Forces in an overdeterminate truss	40
SE 110.29	Torsion of bars	88
SE 110.44	Deformation of trusses	96
SE 110.47	Methods to determine the elastic line	86
SE 110.48	Bending test, plastic deformation	338
SE 110.50	Cable under dead-weight	34
SE 110.53	Equilibrium in a single plane, statically determinate system	24
SE 110.57	Buckling of bars	106
SE 110.58	Free vibrations in a bending beam	181
SE 112	Mounting frame	58/101
SE 130	Forces in a Howe truss	42
SE 130.01	Truss beam: Warren girder	44

TM		
TM 110	Fundamentals of statics	16
TM 110.01	Supplementary set – inclined plane and friction	18
TM 110.02	Supplementary set – pulley blocks	19
TM 110.03	Supplementary set – gear wheels	20
TM 115	Forces in a crane jib	21
TM 121	Equilibrium of moments on pulleys	26
TM 122	Equilibrium of moments on a differential pulley block	27
TM 123	Spur gear unit	282
TM 124	Worm gear unit	283
TM 125	Cable winch	284
TM 140	Free and forced torsional vibrations	192
TM 150	Vibration trainer	178
TM 150.02	Free and damped torsional vibrations	190
TM 150.20	System for data acquisition	180
TM 155	Free and forced vibrations	188
TM 155.20	System for data acquisition	191
TM 161	Rod and gravity pendulum	172
TM 162	Bifilar / trifilar suspension of pendulums	173
TM 163	Torsional vibrations	174
TM 164	Coil spring vibrations	175
TM 170	Balancing apparatus	202
TM 180	Forces at reciprocating engines	206
TM 182	Vibrations on machine foundations	210
TM 182.01	Piston compressor for TM 182	212
TM 200	Fundamentals of mechanical friction	72
TM 210	Dry friction	70
TM 220	Belt drive and belt friction	74/286
TM 225	Friction on the inclined plane	73
TM 232	Bearing friction	368
TM 260	Drive unit for tribological investigations	354
TM 260.01	Rolling friction in friction wheels	356
TM 260.02	Elasto-hydrodynamic behaviour	358
TM 260.03	Dynamic friction in pin – disk	360
TM 260.04	Frictional vibrations	362
TM 260.05	Dynamic friction in cylindrical pin – roller	364
TM 260.06	Pressure distribution in journal bearings	366
TM 262	Hertzian pressure	98
TM 280	Pressure distribution in journal bearings	372
TM 282	Friction in journal bearings	370
TM 290	Journal bearing with hydrodynamic lubrication	374
TM 310	Thread testing	278
TM 320	Screw connections testing	277
TM 400	Hooke's law	100
TM 600	Centrifugal force	162
TM 605	Coriolis force	166
TM 610	Rotational inertia	154
TM 611	Rolling disk on inclined plane	155
TM 612	Kinetic model: flywheel	156
TM 620	Bending elasticity in rotors	196
TM 620.20	System for data acquisition	200
TM 625	Elastic shafts	198
TM 630	Gyroscope	164
TM 632	Centrifugal governor	168

TZ		
TZ 100	Engineering drawing: three-dimensional display	258
TZ 200.02	Engineering drawing: casting	262
TZ 200.08	Engineering drawing: safety catch	263
TZ 200.11	Assembly of bending device	266
TZ 200.61	Engineering drawing: rotationally symmetrical components	260
TZ 200.71	Assembly of lever shears	268
TZ 300	Assembly of lever press	264

WP		
WP 100	Deformation of bars under bending or torsion	90
WP 120	Buckling behaviour of bars	110
WP 121	Demonstration of Euler buckling	108
WP 130	Verification of stress hypotheses	116
WP 140	Fatigue strength test	348
WP 300	Materials testing, 20kN	332
WP 310	Materials testing, 50kN	334
WP 400	Impact test, 25Nm	340
WP 410	Impact test, 300Nm	342
WP 500	Torsion test, 30Nm	344
WP 510	Torsion test 200Nm, motor drive	346
WP 600	Creep rupture test	350
WP 950	Deformation of straight beams	84
WP 960	Beam on two supports: shear force & bending moment diagrams	30
WP 961	Beam on two supports: shear force diagram	32
WP 962	Beam on two supports: bending moment diagram	33



Contact

G.U.N.T. Gerätebau GmbH
Hanskampring 15 – 17
D-22885 Barsbüttel
Germany

Tel. +49 (0)40 67 08 54 - 0
Fax +49 (0)40 67 08 54 - 42
Email sales@gunt.de
Web www.gunt.de



Visit our website
www.gunt.de

